

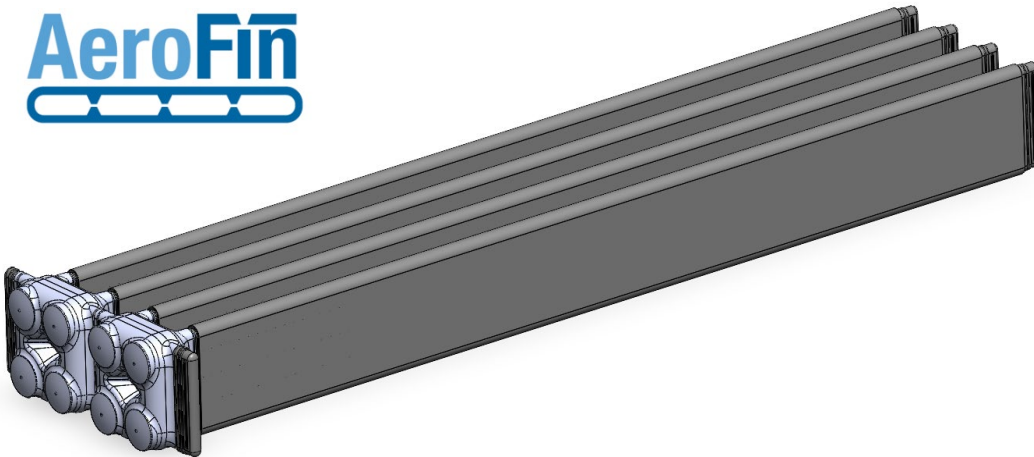

# Infiltrator AeroFin™

## DESIGN AND INSTALLATION MANUAL



The purpose of this manual is to provide the minimum specifications for design and installation of the Infiltrator AeroFin™ in New Hampshire. All local ordinances, requirements, and procedures must be followed. Each revised version of this manual supersedes the previous version.

The configurations presented in this document are common designs and are provided for illustrative purposes. They are not intended to restrict the use of other configurations, which may be utilized provided the design conforms to state and local regulations, as applicable.

**For more detailed design and installation information, please contact Infiltrator Water Technologies at 1-800-221-4436.**

### Table of Contents

INTRODUCTION	2
SYSTEM CONFIGURATIONS	7
SYSTEM DESIGN	11
INSTALLATION INSTRUCTIONS	17
OPERATION AND MAINTENANCE	19
WARRANTY	21

### The Infiltrator AeroFin™

The Infiltrator AeroFin™ (AeroFin) is a proprietary system consisting of four components. The first three components are fabricated in modules called “fins” that are installed within the fourth component, a tightly specified sand called “system sand”. Effluent is dispersed, filtered, and treated by the components of the system through a combination of biological, physical, and chemical processes. The system operates as a media network to support colonized bacteria that treat organic waste.

After exiting the septic tank or treatment unit, effluent progresses through each component as follows:

- 12.75-inch-(in)-tall conduit;
- Geogrid mesh;
- Geotextile fabric; and
- Minimum 6-in-deep layer of system sand.

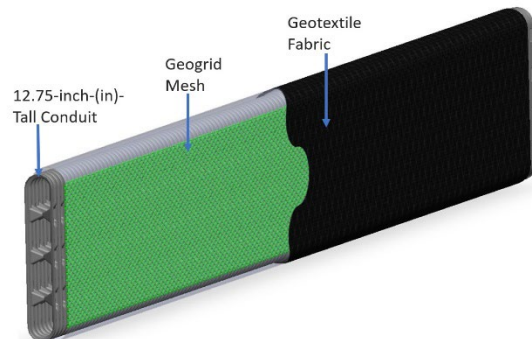

The AeroFin system produces 30-day average TSS and CBOD levels below 5 mg/L when tested in accordance with the NSF/ANSI 40 protocol.

### AeroFin Fin

The AeroFin fins are produced in 4-foot (ft) and 8-ft segments for ease of transport and installation. Individual segments connect to one another using the built-in snap-lock feature to create fin lengths as required by the system design. This snap-lock feature also connects the fins to the AeroFin Manifold and the AeroFin Endcaps.

### AeroFin Manifold

The AeroFin Manifold is installed at the head of the fins and provides equal distribution of effluent into the system from the bottom up. AeroFin Manifolds include a snap-lock feature which facilitates interconnecting individual manifolds in series as well as connecting the manifold to the fins. The AeroFin Manifold may also be installed at the distal end (far end) of individual fins when venting is specified or when serial distribution is used.

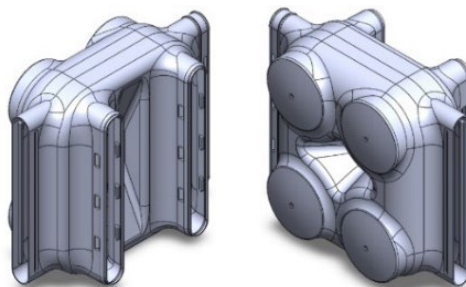

### AeroFin Endcap

AeroFin Endcaps are installed at the distal end of parallel distribution systems or as a cap for the last fin row(s) in a serial distribution system. AeroFin Endcaps may also be installed on the AeroFin Manifold if connections are not required as well as at the end of a cut AeroFin Fin.

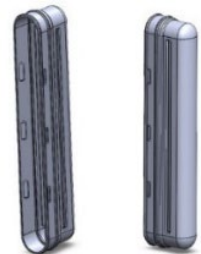

### **System Sand**

System sand is ASTM C-33 (concrete sand), natural or manufactured sand, with 3% or less passing the #200 sieve.

The following minimum system sand dimensions are required for all AeroFin configurations:

- a minimum of 6 in below the fin rows;
- a minimum of 6 in between the fin rows; and
- a minimum of 6 in outside (on each side and on each end) of the fin rows.
- No system sand is required over the system.

Upon exiting the system sand, the treated wastewater is absorbed into the native soils. Typical AeroFin layouts for level and sloped sites are portrayed in the system configurations section of this Infiltrator AeroFin Design and Installation Manual (Manual).

### **Environmental Standards and Technical Support**

All AeroFin systems shall be designed and installed in compliance with the procedures and specifications detailed in this Manual and in the New Hampshire AeroFin product approval. In the event of contradictions between this Manual and New Hampshire rules (Env-Wq 1000), Infiltrator should be contacted for technical assistance at (800) 221-4436.

### **Training and Certification Requirements**

Designers and installers are required to attend a training/certification course on AeroFin presented by Infiltrator or its authorized representative. Infiltrator recommends that professionals involved in the review of AeroFin system designs and inspection of installed systems also become trained and certified.

### **Daily Design Flow**

Residential daily design flow (DDF) is calculated in accordance with Env-Wq 1000 at 150 gallons per day (gpd) per bedroom for residential systems. AeroFin systems serving more than two residences shall calculate DDF in accordance with Env-Wq 1000.

### **Effluent (Wastewater) Strength**

The minimum total fin length required, as shown in Table 1, is based on use with residential strength effluent that has received primary treatment in a septic tank. When designing a system for use with higher strength wastewater contact Infiltrator for technical assistance at (800) 221-4456.

### **Septic Tank**

AeroFin is designed for use following a septic tank and/or an advanced treatment system. All septic tanks and/or advanced treatment systems shall meet and be sized according to Env-Wq 1000.

### **Water Purification Systems**

Water purification systems and water softeners should not discharge into AeroFin. This “backwash” does not require treatment and the additional flow may overload the system. State rules may allow for alternative means of disposal. If there is no alternative means of disposing of this backwash other than into AeroFin, the system will need to be oversized, contact Infiltrator for technical assistance at (800) 221-4456.

### **Separation Distances (Horizontal and Vertical)**

The vertical separation to the seasonal high-water table (SHWT) or impermeable layer is 24 in and is measured from the bottom of the fins. Horizontal setbacks are measured from the outermost edge of the fins.

### **System Soil Cover Material**

A minimum of 6 in of suitable earth cover (topsoil or loam), with a texture similar to the soil at the site and capable of sustaining plant growth, must be placed above the installed system.

### **Infiltrator AeroFin System Definitions**

In this document “minimum system sand footprint area” refers to the surface onto which the fin rows are placed and the 6 inches of system sand between and around the fins. Maintaining this minimum system sand footprint area is required to ensure adequate treatment of the residential-strength wastewater. Minimum System Sand Bed Area (SSBA) refers to the minimum basal area required based upon the soil loading rate for a given DDF. Maintaining this SSBA is required to ensure long-term hydraulic performance. “System sand extension (SSE)” refers to the 6-in system sand layer(s) added to the system sand footprint to make up the difference in area required between the minimum system sand footprint area and the minimum SSBA. Not all systems will require SSE(s). Systems sloping greater than 10% require a minimum 2.5 ft wide SSE on the downslope side of the bed including design SSEs.

### **AeroFin in Beds**

AeroFin may be designed and installed as a bed using the soil application rates from Table 3. Bed bottoms may be level or terraced at various widths to accommodate stepped system design. Multiple beds may be designed if site conditions do not allow for a single bed. A recommended design procedure, which shows equal spacing and symmetrical system sand extensions, is provided in this Manual. However, modified spacing and unsymmetrical SSEs are allowed provided minimum and maximum criteria for bed length and width are met. Infiltrator technical support is available for consultation on unique site designs.

### **Elevated Bed Systems (Mounds)**

Elevated beds are designed for sites with soil, depth to groundwater or restrictive feature constraints that do not allow for in-ground bed systems. An elevated bed system is a soil absorption field with any part of the system above original grade. Side-slope tapering is used to blend the raised portion of the system with the existing grade. Per Env-WQ 1021.04 elevated bed systems require 3 ft fill extensions on each side (measured from the outermost portion of the treatment fin), after which side-slope tapering is to be a maximum of 3 horizontal ft for each 1 ft of vertical drop until it meets existing grade. A 2:1 side-slope taper may be used if necessary to maintain the side slopes on-lot or to avoid an existing permanent structure.

### **System Sand Extensions (SSE)**

AeroFin will treat the wastewater in a properly designed system sand bed footprint, based on the design flow to the system, without regard for the soils the system is placed in or upon. To ensure long-term hydraulic performance, it may be necessary to increase the system sand bed footprint beyond what is

## INTRODUCTION

needed to accommodate the flow-based design treatment area. This additional area is made up with the use of system sand extension(s) (SSE). SSE are a minimum of 6 in in depth. In systems sloping more than 10%, a minimum 2.5 ft wide SSE is required.

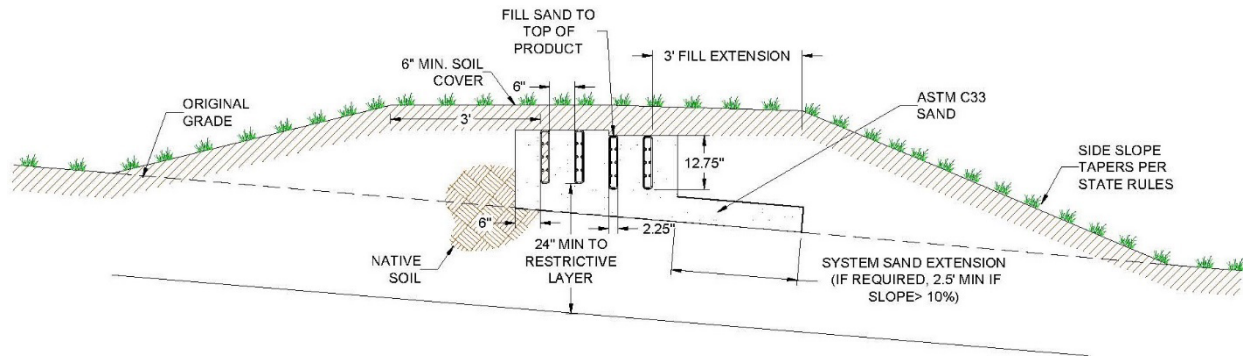

SSEs are placed entirely on the downslope side of the SSBA for sloping AeroFin systems and equally divided on each side of the SSBA for level AeroFin systems.

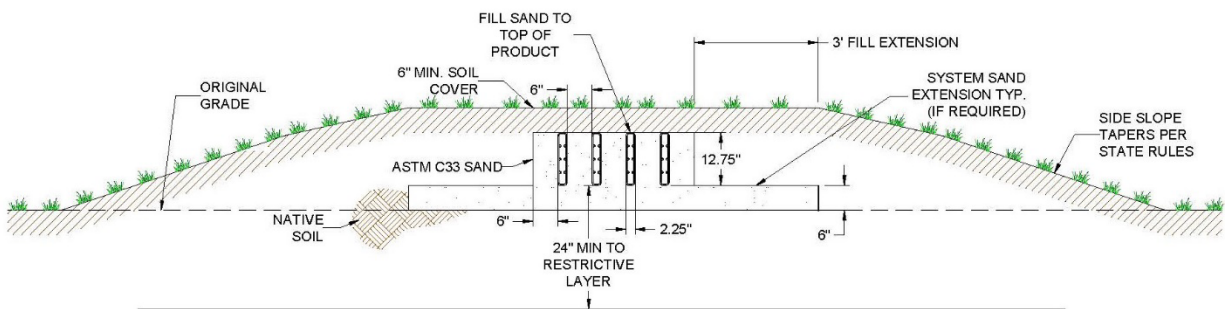

### Row Requirements

- Each AeroFin system must include a minimum of 2 fin rows. Minimum center-to-center spacing is 8.25 in, which accommodates the minimum 6 in of system sand required between fin rows. Spacing may be increased at the discretion of the system designer or as needed to meet the required system sand bed area (SSBA).
- For level beds, fin rows shall be centered in the middle of the SSBA, and the width dimension of any system sand extensions (SSEs) shall be divided evenly on both sides of the SSBA. Level beds may be constructed on sloping terrain if desired.
- For sloping beds, the elevation for each fin row must be provided on the drawing. Fins shall be grouped 6 in from the up-slope edge of the SSBA with any SSE placed entirely on the downslope side of the SSBA. Systems sloping over 10% require a 2.5 ft minimum SSE.
- Each row must be constructed level to within  $\pm 1/2$ -in (total 1-in tolerance) of the specified elevation and preferably should be located parallel with the contour of the site.
- It is most convenient if fin row lengths are designed in exact 4-ft or 8-ft increments to accommodate the length of product as manufactured. However, individual fin segments can be cut to any length from the narrow end of the segment.

# INTRODUCTION

## Parallel Distribution

AeroFin systems may be designed using parallel distribution by interconnecting AeroFin Manifolds as shown below.

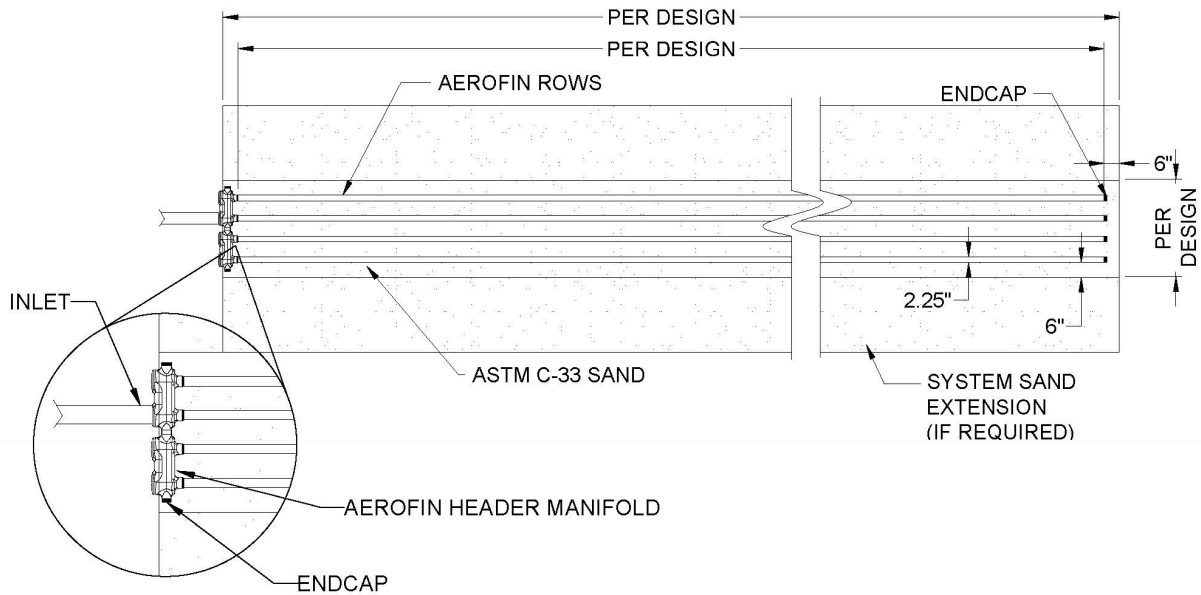

## Serial Distribution

AeroFin systems may be designed using serial distribution. Systems designed to maintain 6-in spacing between fins must be offset at the ends as shown below. To maintain alignment at the fin ends, system width must be adjusted by increasing the spacing between manifolds to allow the AeroFin Manifolds to maintain alignment.

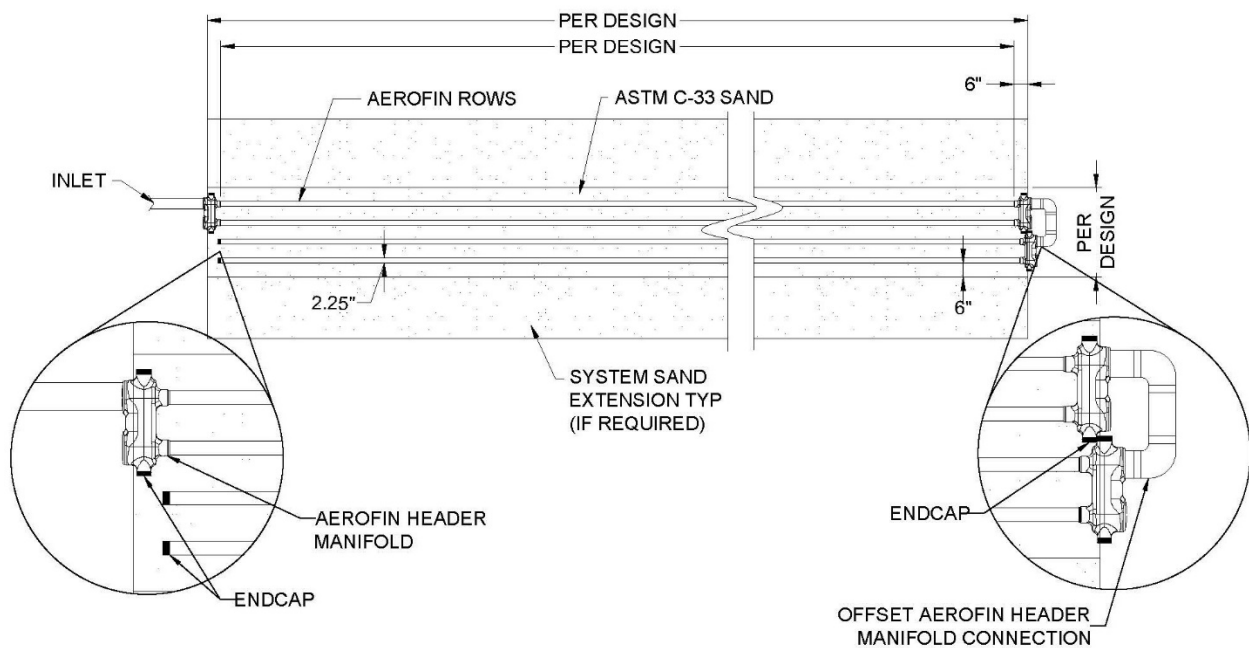

## SYSTEM CONFIGURATIONS

The system configurations presented in this section of the Manual are intended as general guidance. These designs are in no way intended to restrict design flexibility.

### Level Subsurface Bed Systems

#### Cross-Section

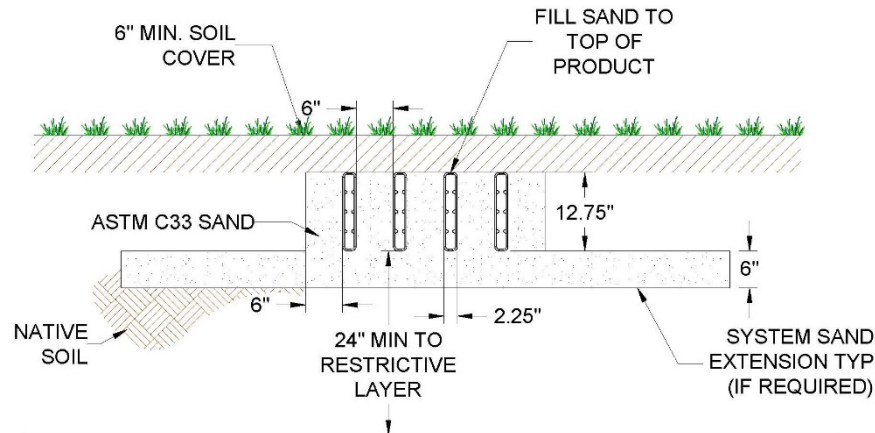

#### Plan View

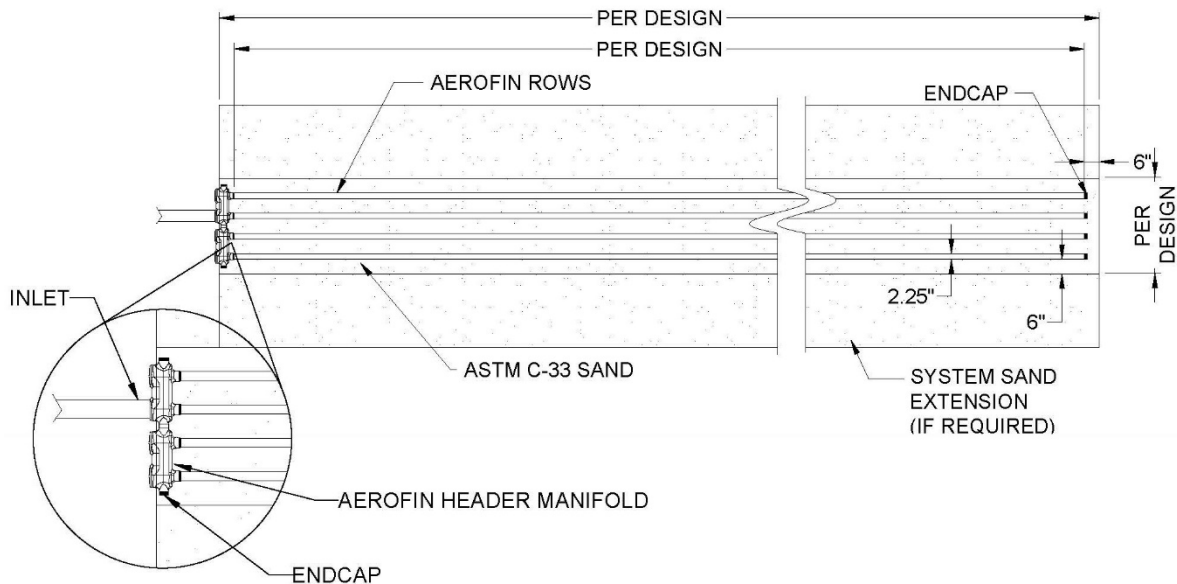

#### NOTES:

1. Number and length of fin rows shall be per the design.
2. Venting is not required but is optional at the discretion of the designer.
3. Pumping to the manifold is not required unless gravity flow cannot be achieved.
4. Parallel distribution is shown, but AeroFin may be installed with either serial or parallel distribution, per state and local regulations.

## Sloped Subsurface Bed Systems

### Cross-Section

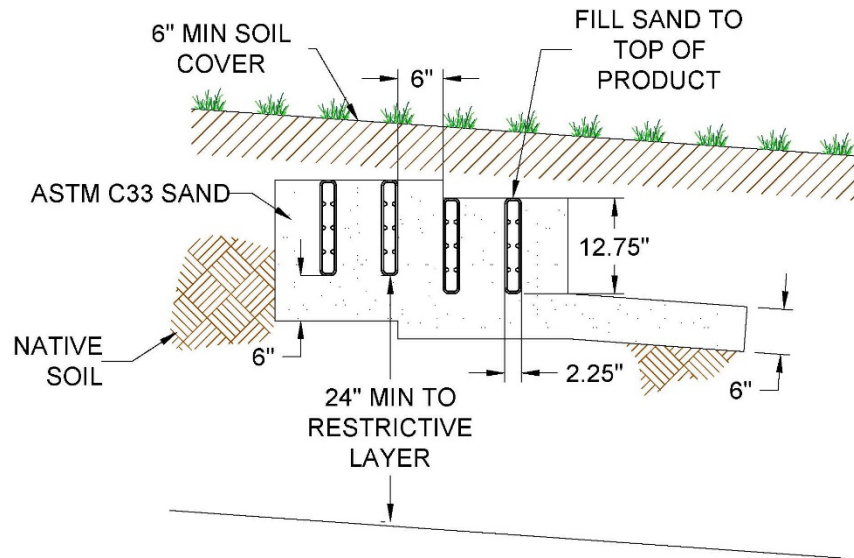

### Plan View

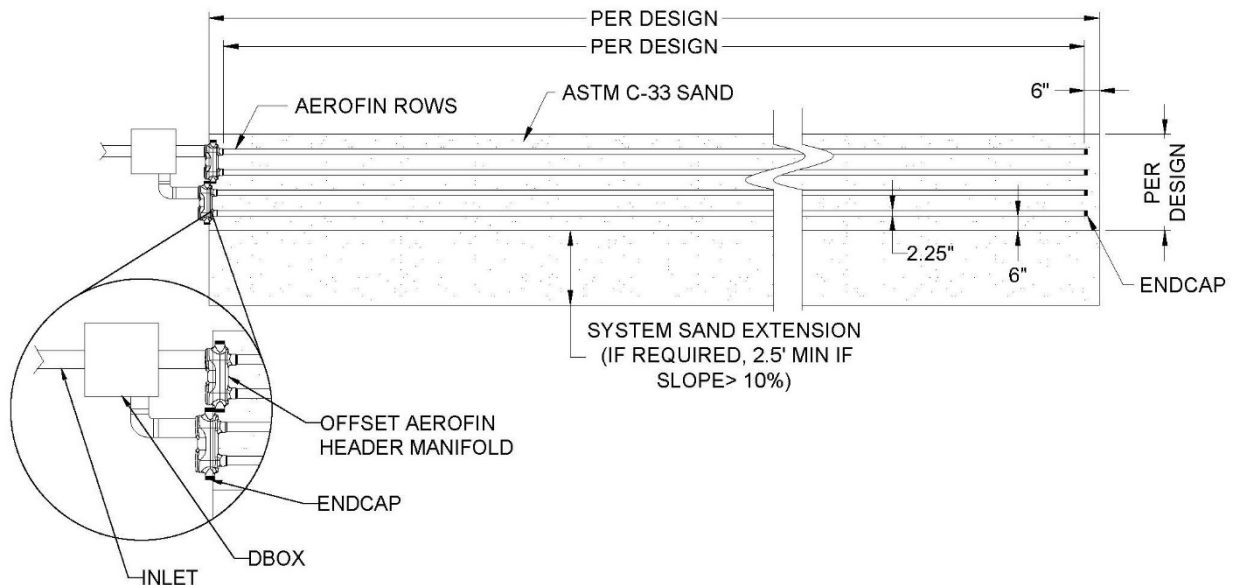

### NOTES:

1. Number and length of fin rows shall be per the design.
2. Venting is not required but is optional at the discretion of the designer.
3. Pumping to the manifold is not required unless gravity flow cannot be achieved.
4. Parallel distribution is shown, but AeroFin may be installed with either serial or parallel distribution, per state and local regulations.
5. Sloping systems may be designed with all fin rows level or they may be stepped using AeroFin sections comprised of fin rows in multiples of two.



## Level Above-Grade Bed Systems

### Cross-Section

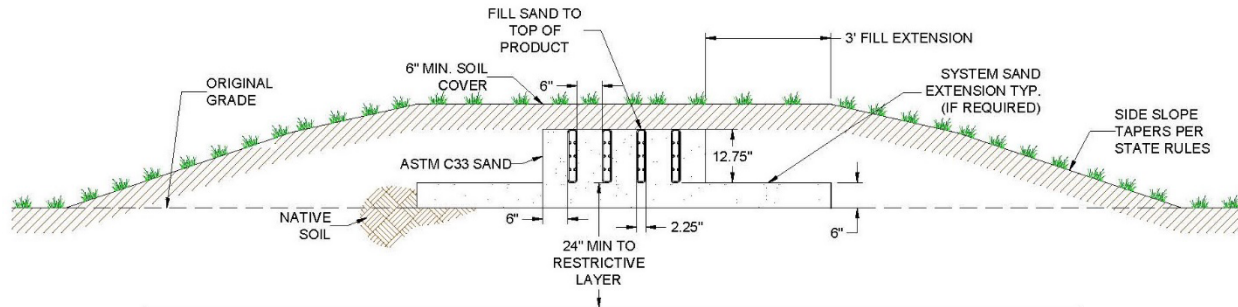

### Plan View

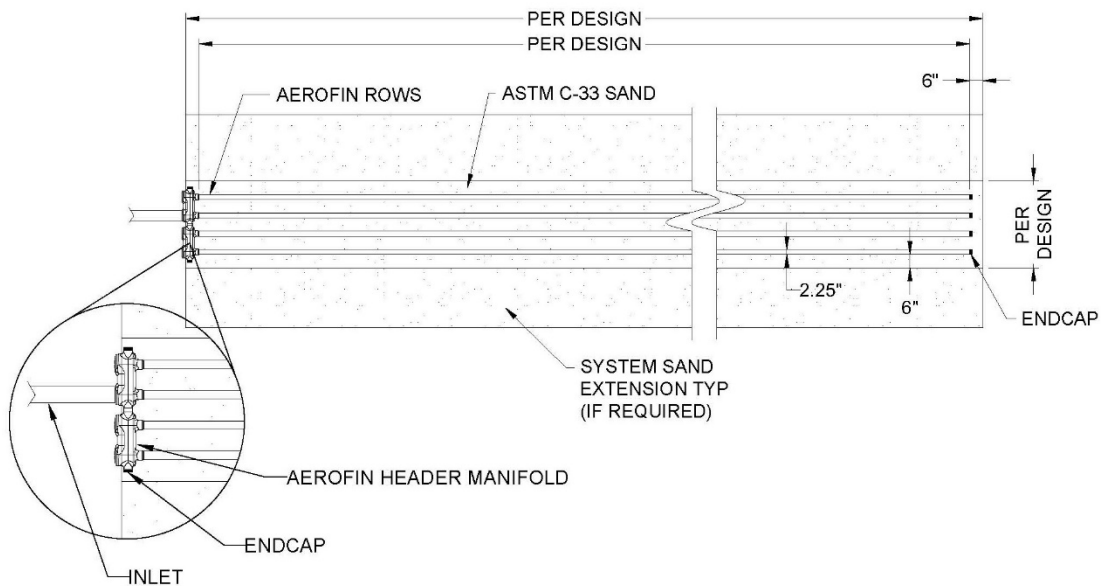

### NOTES:

1. Number and length of fin rows shall be per the design.
2. Venting is not required but is optional at the discretion of the designer.
3. Pumping to the manifold is not required unless gravity flow cannot be achieved.
4. If the infiltrative surface of the AeroFin bed must be elevated to achieve minimum vertical separation requirements, the area between the original grade and the AeroFin system sand shall be comprised of ASTM C33 sand.

## Sloped Above-Grade Systems

### Cross-Section

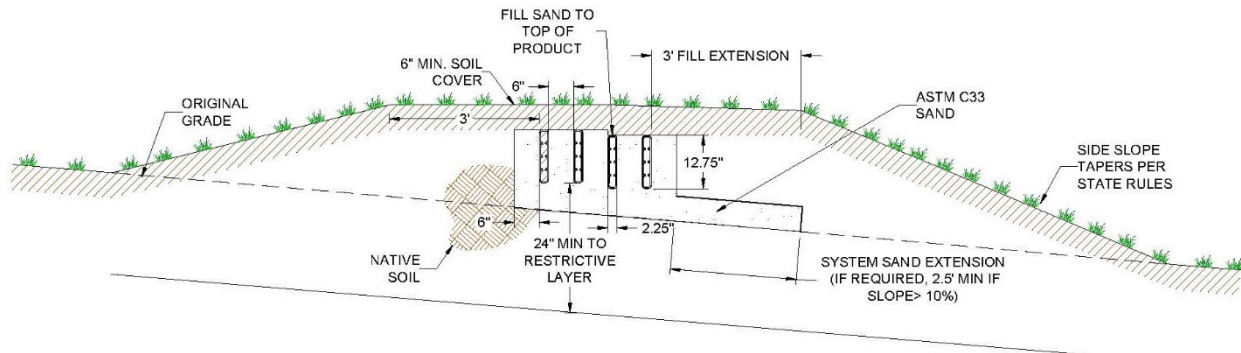

### Plan View

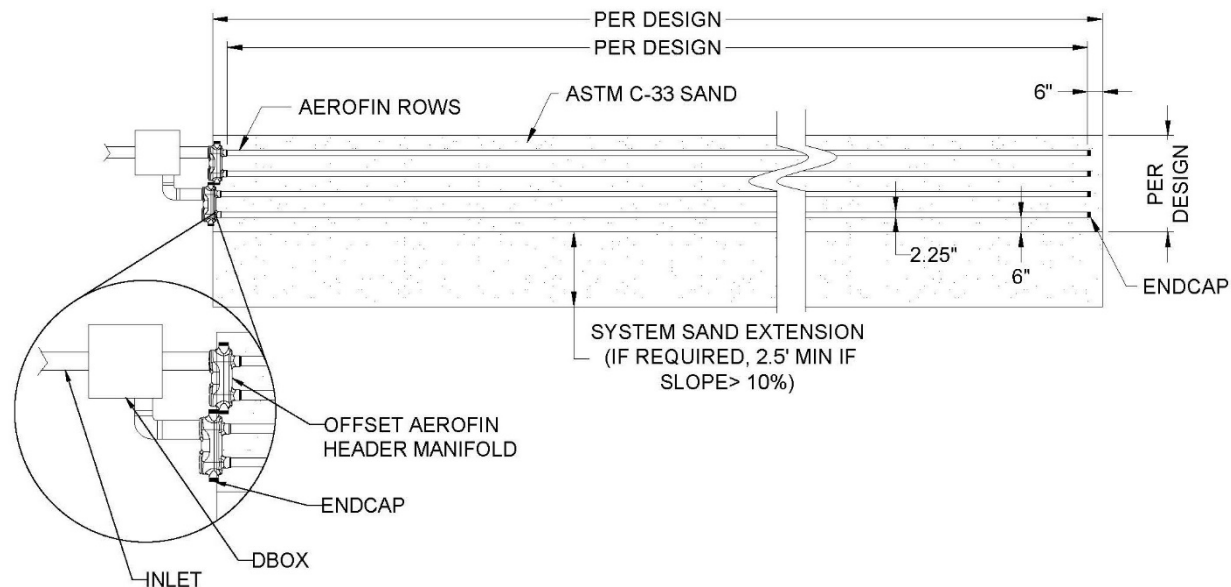

### NOTES:

1. Number and length of fin rows as per the design.
2. Sloping systems may be designed with all fin rows level or they may be stepped using AeroFin sections comprised of fin rows in multiples of two.
3. Venting is not required but is optional at the discretion of the designer.
4. Pumping to the manifold is not required unless gravity flow cannot be achieved.
5. If the infiltrative surface of the AeroFin bed must be elevated to achieve minimum vertical separation requirements, the area between the original grade and the AeroFin system sand shall be comprised of ASTM C33 sand.

The AeroFin system can be designed in five simple steps. The design procedure is provided below, followed by several design examples for typical system configurations.

## Design Procedure

### Step 1: Determine Daily Design Flow (DDF)

Determine residential DDF from Table 1 (below). DDF for commercial applications is calculated in accordance with Env-Wq 1000.

### Step 2: Determine Minimum Length of Fin Required

Determine the minimum length of fin required from Table 1 based on the number of bedrooms. For commercial applications, calculate the minimum length of fin required at 1.88 gal/ft of fin ( $DDF \div 1.88$ ).

**Table 1. Minimum Length of Fin Required**

Number of Bedrooms	Design Flow (gpd)	Minimum Length of Fin (ft)
2	300	160
3	450	240
4	600	320
5	750	400
Each Additional	150	80

### Step 3: Design the System Configuration

Determine the minimum system sand footprint area using the minimum length of fin required as determined from Table 1 and the number of fin rows into which the minimum length of fin required will be divided. The following requirements must be met for system sand footprint area design:

- Determine the fin row length that best fits the site.
- Determine the number of fin rows required to meet the minimum length of fin from Step 2.
- Use Table 2 to determine minimum system sand bed width based on the number of fin rows needed. Systems sloping greater than 10% may require a bed width adjustment in Step 5 to accommodate the minimum SSE requirement of 2.5 ft.

**Table 2: Minimum System Sand Bed Width**

Number of Fin Rows	Minimum Width Per Number of Fin Rows											Each Additional
	2	3	4	5	6	7	8	9	10	11	12	
Minimum Width (ft)	1.88	2.57	3.25	3.94	4.63	5.32	6.00	6.69	7.38	8.07	8.75	0.69
Minimum Width (in)	22.5	30.8	39.0	47.2	55.5	63.8	72.0	80.2	88.5	96.8	105.0	8.3

### Step 4: Determine the Minimum System Sand Bed Area (SSBA)

Using common practice and in accordance with Env-Wq 1000, determine the percolation rate for the site. Given the site percolation rate and the number of bedrooms in the design, determine the

## SYSTEM DESIGN

minimum required SSBA using Table 3. For commercial applications, calculate the minimum SSBA as  $DDF \div \text{Soil Loading Rate (SLR)}$ .

**Table 3: Minimum System Sand Bed Area (SSBA)**

Percolation Rate (mpi)	Soil Loading Rate (SLR) (gpd/ft <sup>2</sup> )	Number of Bedrooms Minimum Bed Area (sf)				
		2 BR	3 BR	4 BR	5 BR	Each Additional BR
1 – 9	2.25	134	200	267	334	67
10 – 13	1.79	168	252	336	419	84
14 – 19	1.60	188	282	375	469	94
20 – 30	1.47	205	307	409	511	103
31 – 40	1.30	231	347	462	577	116
41 – 50	1.12	268	402	536	670	134
51 – 60	1.00	300	450	600	750	150

Note: Consult Infiltrator technical assistance for high strength effluent requirements.

Bed area is calculated as  $DDF \div \text{SLR}$ .

### **Step 5: Make area adjustments, as necessary.**

The minimum system sand footprint area from Step 3 and minimum SSBA from Step 4 cannot be reduced. These areas must be maintained to ensure adequate area for placement of the AeroFin system as well as long-term infiltration of treated effluent into the native soil.

Area adjustments may be necessary as follows:

- If the minimum SSBA determined using Step 4 (Table 3) is smaller than the area of the system sand footprint determined in Step 3, and the system does not require a minimum SSE, no area adjustments are necessary.
- If the minimum SSBA determined using Step 4 (Table 3) is larger than the area of the system sand footprint determined in Step 3, the system sand footprint must be increased by adding SSE(s).
- In either case, if the system slope is greater than 10%, the system will require a 2.5 ft minimum SSE on the downslope side.
- For ease of construction, final bed measurements may be rounded up to the nearest foot.

When making adjustments to the width of the system sand footprint:

- In level system applications, additional width shall be provided by the use of 6-inch-deep SSEs which are evenly divided on each side;
- In sloped system applications, additional width shall be provided by the use of a 6-inch-deep SSE placed entirely on the downslope side.

**NOTE:** The length of the bed area may be altered, but only by extending the length of the fin rows. Fins are manufactured in 4- and 8-ft segments but may be cut to any length.

## Design Example

Single family residence; 3-bedrooms (450 gpd); soil has a percolation rate of 28 mpi.

### Step 1: Determine Daily Design Flow

Residential DDF for a 3-bedroom home is 450 gpd, per Table 1.

Number of Bedrooms	Design Flow (gpd)	Minimum Fin Length (ft)
2	300	160
<b>3</b>	<b>450</b>	<b>240</b>
4	600	320
5	750	400
Each Additional	150	80

**Table 1.** Minimum Length of Fin Required

### Step 2 Determine Minimum Length of Fin Required

For a 3-bedroom home, the minimum fin length required is 240 ft, per Table 1.

### Step 3: Design the System Sand Configuration

Using a row length of 60 ft to eliminate cutting will require 4 fins providing 240 total ft of fin. This meets the 240 ft minimum length requirement from Step 2. Referencing Table 2, the system sand bed width required for 4 fins is 3.25 ft (39 in).

Number of Fin Rows	Minimum Width Per Number of Fin Rows											
	2	3	4	5	6	7	8	9	10	11	12	Each Additional
Minimum Width (ft)	1.88	2.57	3.25	3.94	4.63	5.32	6.00	6.69	7.38	8.07	8.75	0.69
Minimum Width (in)	22.5	30.8	39.0	47.2	55.5	63.8	72.0	80.2	88.5	96.8	105.0	8.3

**Table 2:** Minimum System Sand Bed Width

### Step 4: Determine the Minimum System Sand Bed Area (SSBA)

Per Table 3, the minimum SSBA required for a 3 bedroom residence on a site with a percolation rate of 28 mpi is 307 sq ft.

Percolation Rate (mpi)	Soil Loading Rate (SLR) (gpd/ft <sup>2</sup> )	Number of Bedrooms Minimum Bed Area (sf)				
		2 BR	3 BR	4 BR	5 BR	Each Additional BR
1 – 9	2.25	134	200	267	334	67
10 – 13	1.79	168	252	336	419	84
14 – 19	1.60	188	282	375	469	94
20 – 30	1.47	205	<b>307</b>	409	511	103
31 – 40	1.30	231	347	462	577	116
41 – 50	1.12	268	402	536	670	134
51 – 60	1.00	300	450	600	750	150

**Table 3:** Minimum System Sand Bed Area

## SYSTEM DESIGN

### **Step 5: Make area adjustments, as necessary.**

#### *Option 1: Level System*

On a level system, the required SSE will be evenly divided on both sides of the system sand footprint.

From Step 3 the system sand configuration is by 3.25 ft wide by 61 ft long for a total system sand footprint of 198.25 ft<sup>2</sup>.

- From Step 4 a 450 gpd system requires a minimum SSBA of 307 ft<sup>2</sup>. 307 ft<sup>2</sup> is greater than the 198 ft<sup>2</sup> system sand footprint. Therefore, an adjustment to the size of the system footprint is necessary by adding SSE(s).
  - Divide the minimum SSBA by the length of the system sand bed.  $307 \text{ ft}^2 \div 61 \text{ ft} = 5.04 \text{ ft}$ . The width of the 3.25 ft-wide system sand footprint must be increased to 5.04 ft minimum.
  - Subtract the original system sand footprint width from the required system width to determine the required SSE.  $5.04 \text{ ft} - 3.25 \text{ ft} = 1.79 \text{ ft SSE}$ .
  - Divide the SSE width required by 2 to determine the width of the SSE to be added to each side of the system sand footprint.  $1.79 \text{ ft} \div 2 = 0.90 \text{ ft}$ . Round 0.90 ft up to 1.0 ft for ease of construction.
  - The system footprint must be widened by 2.0 ft in total, by adding 1.0 ft of system sand to each side of the system sand footprint, resulting in a total bed width of 5.25 ft. The final SSBA measurement is  $5.25 \text{ ft} \times 61 \text{ ft} = 320.25 \text{ ft}^2$ , which exceeds the minimum 307 ft<sup>2</sup> SSBA requirement as calculated in Step 4.

Cross Section:

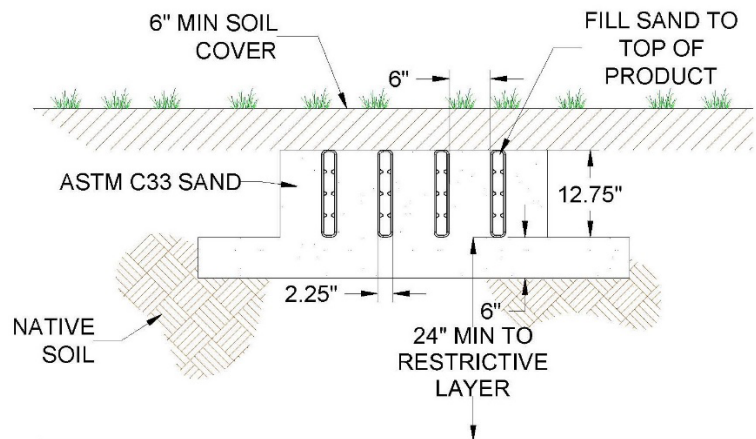

## SYSTEM DESIGN

Plan View:

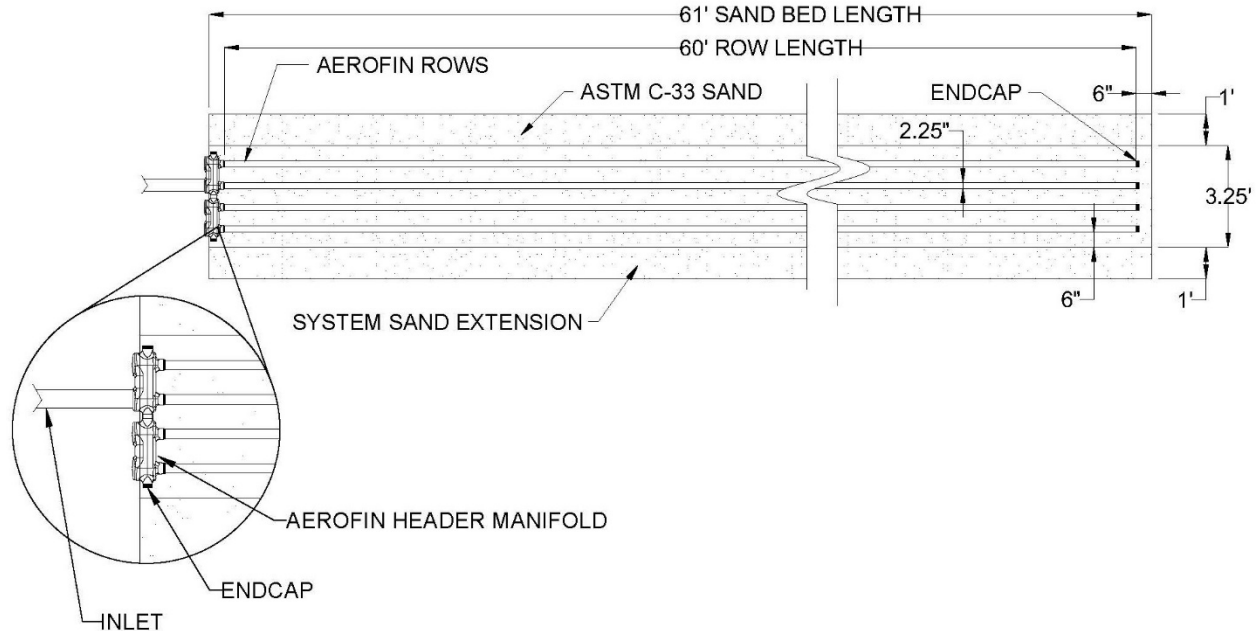

### Option 2: Sloped System

On a sloped systems the entire SSE is placed on the downslope side of the SSBA.

From Step 3 the system sand configuration is by 3.25 ft wide by 61 ft long for a total system sand footprint of 198.25 ft<sup>2</sup>.

- From Step 4 a 450 gpd system requires a minimum SSBA of 307 ft<sup>2</sup>. 307 ft<sup>2</sup> is greater than the 198 ft<sup>2</sup> system sand footprint. Therefore, an adjustment to the size of the system footprint is necessary by adding SSE(s).
  - Divide the minimum SSBA by the length of the system sand bed.  $307 \text{ ft}^2 \div 61 \text{ ft} = 5.04 \text{ ft}$ . The width of the 3.25 ft system sand footprint must be increased to 5.04 ft.
  - Subtract the original system sand footprint width from the required system width to determine required SSE width.  $5.04 \text{ ft} - 3.25 \text{ ft} = 1.79 \text{ ft SSE}$ . Round up to 2.0 ft for ease of construction.
  - The system footprint must be widened by 2.0 ft by adding 2.0 ft of system sand to the downslope side of the system sand footprint, resulting in a total width of 5.25 ft. The final SSBA measurement is  $5.25 \text{ ft} \times 61 \text{ ft} = 320.25 \text{ ft}^2$  which exceeds the 307 ft<sup>2</sup> SSBA requirement as calculated in Step 4.
  - This system slopes less than 10% so the 2.0 ft SSE is adequate.

# SYSTEM DESIGN

Cross Section:

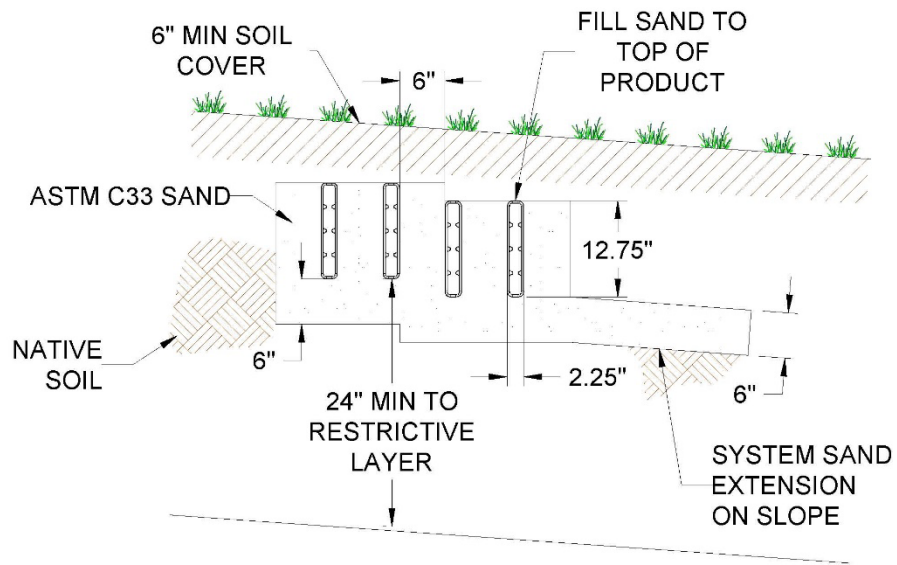

Plan View:

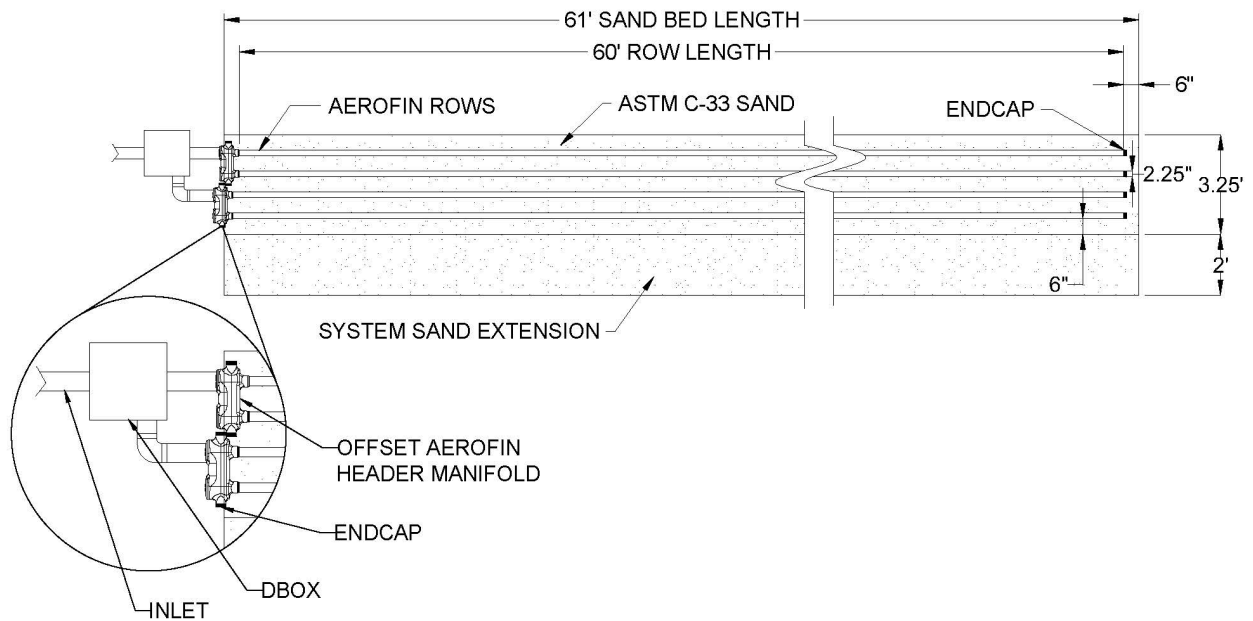



## INSTALLATION INSTRUCTIONS

---

### Before You Begin

These installation instructions are for AeroFin. AeroFin may only be installed according to applicable state and local health department requirements.

If unsure of the installation requirements for a site, contact your local health department. If unsure of the applicability of AeroFin for a given site, contact Infiltrator Water Technologies. The soil and site evaluation and the design of the onsite system must be reviewed, approved and a construction permit obtained from the local permitting authority before installation.

#### Materials and Equipment Needed

- |   |   |
|---|---|
| <input type="checkbox"/> AeroFin Fins           | <input type="checkbox"/> Backhoe                      |
| <input type="checkbox"/> AeroFin Manifold       | <input type="checkbox"/> Laser, transit or level      |
| <input type="checkbox"/> AeroFin Endcaps        | <input type="checkbox"/> Shovel and rake              |
| <input type="checkbox"/> ASTM C-33 system sand  | <input type="checkbox"/> 4-in inspection port and cap |
| <input type="checkbox"/> AeroFin Row Spacer(s)  | <input type="checkbox"/> Tape measure                 |
| <input type="checkbox"/> PVC pipe and couplings |   |

#### Common practices shall apply to the installation of AeroFin. These include, but are not limited to:

- avoid soil compaction on the infiltrative surface area, including all areas downslope of a sloped system;
- use a tracked vehicle for material installation if possible;
- avoid installation during wet periods; and
- install the AeroFin components and system sand on the same day that the system footprint is excavated/exposed.

### Handling Instructions

Compression of the AeroFin components during transport, storage, or construction shall be avoided.

### Excavating and Preparing the Site

**NOTE:** AeroFin may not be installed during periods when the soil is sufficiently wet to exceed its plastic limit, as this causes construction machinery to smear the soil.

1. Stake out the locations of tank(s), pipes, and corners of the system to be tilled/excavated, per system design. Set the elevations as shown on the approved plan.
2. Install sedimentation and erosion control measures if required or needed.

**NOTE:** The installation of temporary drainage swales/berms (surface diversions) may be necessary to protect the site during rainfall events.

3. Excavate the system area or till the ground as per the design.
4. Rake the bed bottom and sides (when applicable) if smearing has occurred during excavation. Remove large stones and protruding roots.

**NOTE:** Smearing does not occur in sandy soils, so raking is not necessary. In fine textured soils (silts and clays), avoid walking on the excavation bottom to prevent compaction and loss of soil structure.

5. Verify that the bottom of the bed is at the proper elevation from side-to-side and from end-to-end using a level, transit, or laser.

### Installing AeroFin

1. Install the 6-in deep system sand basal layer over the entire bed area as per the design. System sand should be leveled and stabilized prior to placement of the AeroFin system. Installer should retain records certifying that system sand meets ASTM C-33 requirements.
2. Assemble the AeroFin Manifold and place it in the proper location(s) on the system sand basal area.
3. Place AeroFin components on the surface of the system sand in the configuration shown on the system design. Using the snap-lock feature, snap the fins to the AeroFin Manifold, then connect fins end-to-end to create rows of the required length.
4. Fin rows shall be installed level to within +/- ½-in (total 1-in tolerance) of the specified elevation. A laser level or transit is recommended to ensure proper alignment.
5. Fin rows shall be:
  - installed parallel to any topographic contours; and
  - separated by a minimum of 6 in of system sand.

#### **AeroFin Row Spacer**

Infiltrator offers an installation aid for installing fin rows, ensuring the minimum 6 in of system sand between fin rows is maintained throughout the system and fins do not move during installation. The AeroFin row spacer is reusable and available where AeroFin components are sold.

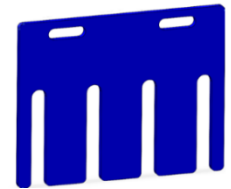

6. Once the fins are placed on the surface of the system sand and the distal end manifold system and/or end caps are connected to the fins per design, additional system sand shall be ladled between and to the top of each of the fin rows and lightly compacted by walking in the sand after placement for fin stabilization and support. System sand shall also be installed on each side and at each end of the backfilled fin rows, per the design.
7. Remove AeroFin row spacers.

### Covering the System

**NOTE:** Before backfilling, the system shall be inspected and approved by a representative of the local health department, in compliance with state and local regulations and procedures.

1. Material placed around the system sand and above the fins may be additional system sand or material meeting state and local requirements. However, the final 6 in placed above or adjacent to the fins shall be comprised of material that will sustain plant growth.
2. Backfill the bed by pushing material over the AeroFin system. It is best to mound several extra inches of soil over the finish grade to allow for settling. This also ensures that runoff is diverted away from the system. Keep a minimum of 12 in of consolidated cover over the fins before driving over the system. Do not drive over the system while backfilling in sand.
3. After the system is covered, the site should be seeded or sodded to mitigate the potential for erosion.

**NOTE:** If the system is for new home construction, it is important to leave marking stakes along the boundary of the system. This will notify contractors of the system location so they will not cross it with equipment or vehicles. Vehicles and equipment should remain clear of the downslope side of the system.

## OPERATION AND MAINTENANCE

---

An AeroFin system may be out of sight, but it definitely should not be out of mind. With proper standard maintenance and by being more aware of daily living habits, AeroFin users will greatly improve the life and health of the system. Here are some guidelines to help you protect your investment.

### Inside the Home

1. Large volumes of water over a short period of time will flush untreated solids out of the septic tank into the leachfield.
  - Practice conservation every day.
  - Space out heavy water-using activities such as washing clothes and taking showers.
  - Repair leaky faucets and valves. Consider replacing old fixtures with new low-flow fixtures.
2. Remember that a septic system uses natural biological processes so only biodegradable waste should go in it.
  - No cigarette butts, tissues, sanitary napkins, disposable diapers, cat litter, coffee grounds, or cotton swabs, etc.
  - No paints, oils, chemical drain cleaners, thinners, solvents, poisons, or pesticides. These toxic chemicals not only kill helpful bacteria but may contaminate the groundwater.
  - No grease or cooking oils. Grease may harden in the septic tank's scum layer and accumulate until it blocks the inlet or outlet. If you melt grease and pour it down the drain, it may run through the septic tank and then harden, clogging the system.
  - Go easy with your garbage disposal. Using a garbage disposal typically doubles the rate of solids buildup in the septic tank. To avoid frequent pumpouts, compost your garbage or put it in the trash.
  - Be cautious with household chemicals. Disinfectants, ammonia, bathroom cleaners, bleach, etc. can kill the bacteria your system needs in order to operate properly. Allow the system to dilute and neutralize them a little at a time.

### Outside the Home

1. Have your tank checked for sludge and scum accumulation by a septic system contractor every two to three years. If you have high water usage or a garbage disposal, the inspections should be more frequent.
2. Keep surface water away from the AeroFin installation area. Divert downspouts, roof drainage, driveway runoff, and sump pump discharge away from the system. Landscape your yard to channel rainwater away.
3. Encourage the right plants. Remove trees such as willows that like "wet feet". Their roots may penetrate and damage the dispersal area. Grow grass or ground cover over the system to prevent soil erosion.
4. Avoid physical damage. Don't drive over the system or compact the soil with heavy equipment. Don't dig in or build anything on the system.

### Trouble Shooting

In the event of a system malfunction, contact the authorized service representative. Indications your system may need service include persistent septic odor; unusually wet area atop and/or around the

## OPERATION AND MAINTENANCE

---

system; “ponding” of effluent on the lawn; or “breakout” of effluent along the side of a slope. If any of these circumstances arise contact the authorized service representative.

### **Repair**

The authorized representative shall be contacted when there are indications of malfunction with AeroFin. When visiting the site, the authorized representative shall do the following:

- Assess the present condition of the AeroFin system, and the surrounding area
- Research the history of use, including:
  - water volume use
  - contaminants
- Evaluate site for groundwater intrusion and surface water drainage patterns
- Inspect septic tank
- Inspect the fins
- Check the home for leaks

Upon completion of the site visit, the authorized representative should contact the Infiltrator Water Technologies Technical Services Department with his/her report.

## WARRANTY

---

### INFILTRATOR WATER TECHNOLOGIES STANDARD LIMITED WARRANTY

(a) The structural integrity of each unit, end cap and other accessory manufactured by Infiltrator (collectively referred to as “Units”), when installed and operated in an onsite wastewater system in accordance with Infiltrator’s installation instructions, is warranted to the original purchaser (“Holder”) against defective materials and workmanship for one year from the date upon which a septic permit is issued for the septic system containing the Units; provided, however, that if a septic permit is not required for the septic system by applicable law, the one (1) year warranty period will begin upon the date that installation of the septic system commences. In order to exercise its warranty rights, Holder must notify Infiltrator in writing at its corporate headquarters in Old Saybrook, Connecticut within fifteen (15) days of the alleged defect. Infiltrator will supply replacement Units for those Units determined by Infiltrator to be defective and covered by this Limited Warranty. Infiltrator’s liability specifically excludes the cost of removal and/or installation of the Units.

(b) THE LIMITED WARRANTY AND REMEDIES IN SUBPARAGRAPH (a) ARE EXCLUSIVE. THERE ARE NO OTHER WARRANTIES WITH RESPECT TO THE UNITS, INCLUDING NO IMPLIED WARRANTIES OF MERCHANTABILITY OR FITNESS FOR A PARTICULAR PURPOSE.

(c) This Limited Warranty shall be void if any part of the AeroFin system (unit, end cap or other accessory) is manufactured by anyone other than Infiltrator. The Limited Warranty does not extend to incidental, consequential, special or indirect damages. Infiltrator shall not be liable for penalties or liquidated damages, including loss of production and profits, labor and materials, overhead costs, or other losses or expenses incurred by the Holder or any third party. Specifically excluded from Limited Warranty coverage are damage to the Units due to ordinary wear and tear, alteration, accident, misuse, abuse or neglect of the Units; the Units being subjected to vehicle traffic or other conditions which are not permitted by the installation instructions; failure to maintain the minimum ground covers set forth in the installation instructions; the placement of improper materials into the system containing the Units; failure of the Units or the septic system due to improper siting or improper sizing, excessive water usage, improper grease disposal, or improper operation; or any other event not caused by Infiltrator. This Limited Warranty shall be void if the Holder fails to comply with all of the terms set forth in this Limited Warranty.

Further, in no event shall Infiltrator be responsible for any loss or damage to the Holder, the Units, or any third party resulting from installation or shipment, or from any product liability claims of Holder or any third party. For this Limited Warranty to apply, the Units must be installed in accordance with all site conditions required by state and local codes; all other applicable laws; and Infiltrator’s installation instructions.

(d) No representative of Infiltrator has the authority to change this Limited Warranty in any manner whatsoever, or to extend this Limited Warranty. No warranty applies to any party other than the original Holder.

The above represents the standard Limited Warranty offered by Infiltrator. A limited number of states and counties have different warranty requirements. Any purchaser of Units should contact Infiltrator’s corporate headquarters in Old Saybrook, Connecticut, prior to such purchase, to obtain a copy of the applicable warranty, and should carefully read that warranty prior to the purchase of Units.



4 Business Park Road  
P.O. Box 768  
Old Saybrook, CT 06475  
860-577-7000 • Fax 860-577-7001  
1-800-221-4436  
www.infiltratorwater.com

Patents: <https://www.infiltratorwater.com/patents/>

Infiltrator Water technologies is a wholly owned subsidiary of Advanced Drainage Systems, Inc. (ADS).

© 2022 Infiltrator Water Technologies, LLC. All rights reserved. Printed in U.S.A.

AF67 0822