

TANK EXTERIOR	
LENGTH	134.2 [3,409]
WIDTH	61.7 [1,567]
HEIGHT	54.5 [1,384]

LIQUID DEPTH	44.0 [1,118]
INVERT DROP	3.0 [76]
FREEBOARD	10.1 [257]

TOTAL CAPACITY	1,309 GAL [4,956 L]
WORKING VOLUME	1,111 GAL [4,207 L]

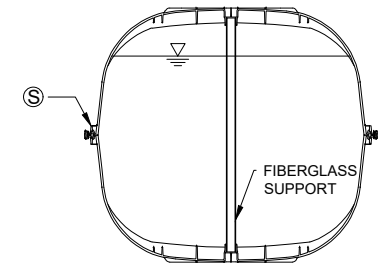
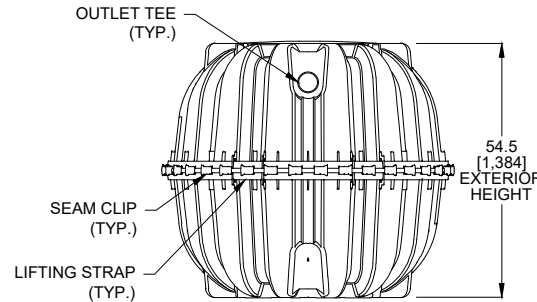
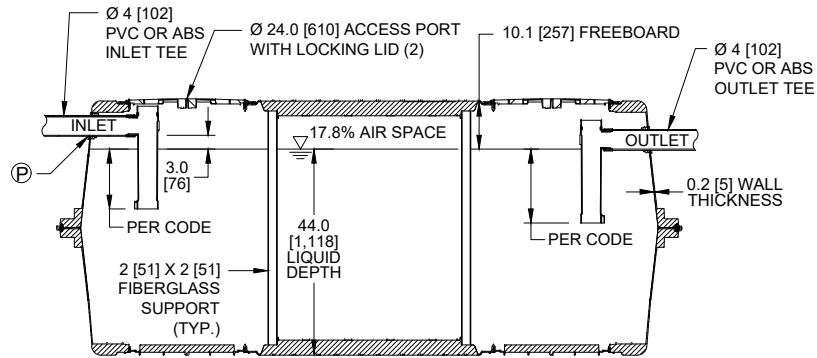

NOTES:

1. ALL DRAWING DIMENSIONS IN INCHES [MILLIMETERS] OR AS NOTED.
2. EXTERIOR OF ACCESS OPENING LID INCLUDES THE FOLLOWING WARNING IN ENGLISH, FRENCH & SPANISH: "DANGER DO NOT ENTER: POISON GASES."
3. TANK MARKINGS WILL INCLUDE: MANUFACTURER NAME, MODEL NUMBER, LIQUID CAPACITY, DATE OF MANUFACTURE, MAXIMUM BURIAL DEPTH, INLET, AND OUTLET.
4. MAXIMUM BURIAL DEPTH IS 48 in [1,219 mm].
5. MINIMUM BURIAL DEPTH IS 6 in [152 mm].
6. TANK IS FOR NON-TRAFFIC APPLICATIONS.
7. AIRSPACE IS 17.8%.
8. OUTLET TEE IS COMPATIBLE WITH AN EFFLUENT FILTER.
9. LENGTH TO WIDTH RATIO IS 2.3:1 (120.1-INCH LENGTH / 51.8-INCH WIDTH = 2.3).

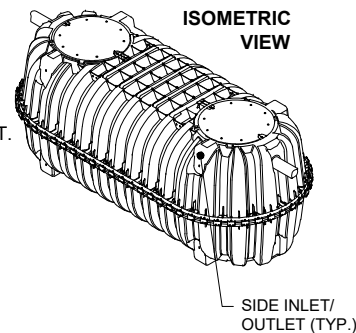

INFILTRATOR WATER TECHNOLOGIES
4 Business Park Rd. Old Saybrook, CT 06475
(800) 221-4436

CM-1060
1-Compartment
Septic Tank Configuration

Drawn by: JLK	Date: 1/7/2022
Scale: NOT TO SCALE	Checked by: DJL
Sheet: 1 of 1	

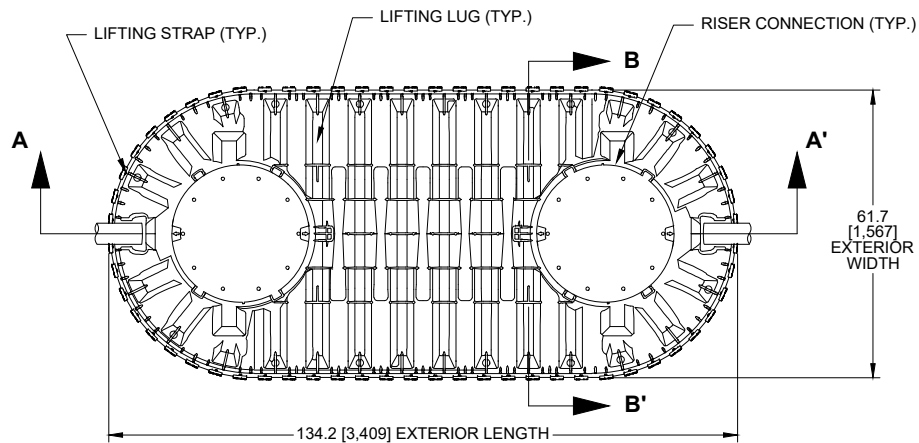

TOP VIEW

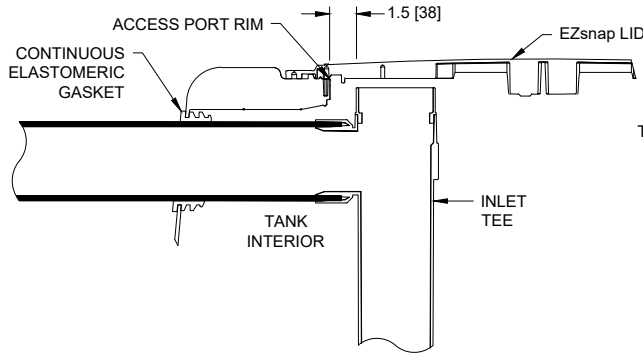

PIPE PENETRATION SECTION DETAIL

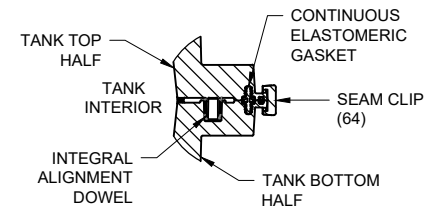

MID-HEIGHT SEAM SECTION DETAIL

TANK EXTERIOR	
LENGTH	134.2 [3,409]
WIDTH	61.7 [1,567]
HEIGHT	54.5 [1,384]

LIQUID DEPTH	44.0 [1,118]
INVERT DROP	3.0 [76]
FREEBOARD	10.1 [257]

TOTAL CAPACITY	1,309 GAL [4,956 L]
WORKING VOLUME	1,111 GAL [4,207 L]
COMPARTMENT A VOL.	741 GAL [2,805 L]
COMPARTMENT B VOL.	370 GAL [1,402 L]

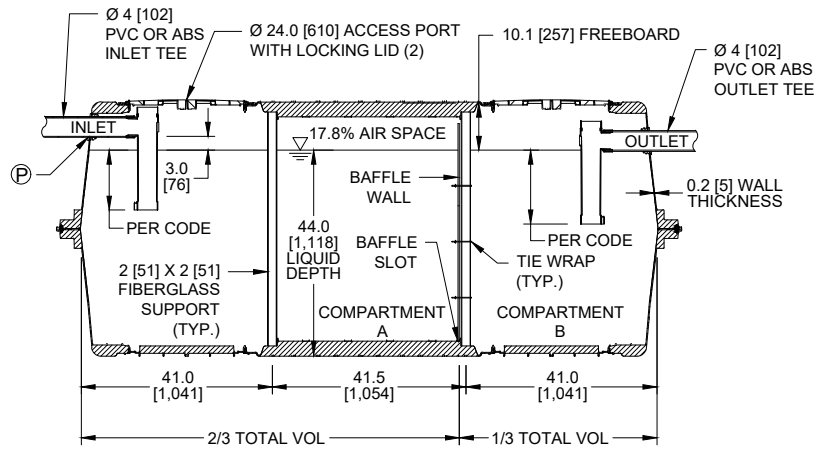

SECTION A - A'

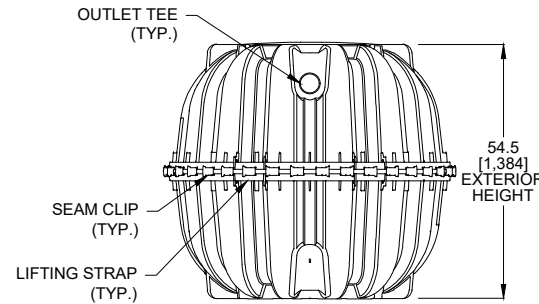

END VIEW

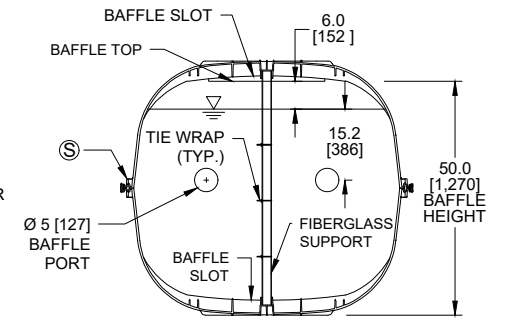

SECTION B - B'
BAFFLE DETAIL

NOTES:

- ALL DRAWING DIMENSIONS IN INCHES [MILLIMETERS] OR AS NOTED.
- EXTERIOR OF ACCESS OPENING LID INCLUDES THE FOLLOWING WARNING IN ENGLISH, FRENCH & SPANISH: "DANGER DO NOT ENTER: POISON GASES."
- TANK MARKINGS WILL INCLUDE: MANUFACTURER NAME, MODEL NUMBER, LIQUID CAPACITY, DATE OF MANUFACTURE, MAXIMUM BURIAL DEPTH, INLET, AND OUTLET.
- MAXIMUM BURIAL DEPTH IS 48 in [1,219 mm].
- MINIMUM BURIAL DEPTH IS 6 in [152 mm].
- TANK IS FOR NON-TRAFFIC APPLICATIONS.
- AIRSPACE IS 17.8%.
- OUTLET TEE IS COMPATIBLE WITH AN EFFLUENT FILTER.
- LENGTH TO WIDTH RATIO IS 2.3:1 (120.1-INCH LENGTH / 51.8-INCH WIDTH = 2.3).
- FREE VENT AREA BETWEEN TOP OF BAFFLE WALL AND BOTTOM OF TOP BAFFLE SLOT IS 129.7 in².
- BAFFLE WALL THICKNESS IS 0.31 in [8 mm].

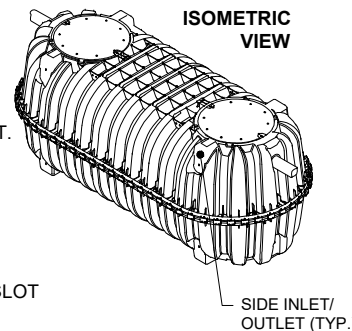

ISOMETRIC VIEW



INFILTRATOR WATER TECHNOLOGIES
4 Business Park Rd. Old Saybrook, CT 06475
(800) 221-4436

CM-1060
2-Compartment
Septic Tank Configuration

Drawn by: JLK	Date: 1/7/2022
Scale: NOT TO SCALE	Checked by: DJL
	Sheet: 1 of 1