

The EZsnap riser is designed to create an easy-to-assemble watertight riser system for septic tanks, pump tanks, and cisterns.

The EZsnap riser features click and lock technology eliminating the need for assembly tools, sealant/caulk and hardware. Easily cast into precast structures providing a secure watertight fit. The 24" diameter EZsnap riser is available in 2", 6" and 12" tall sections that nest together making for efficient storage and shipping.



CLICK and LOCK RISER TECHNOLOGY

2, 6 & 12 Inch Riser System Available in Green and Black

- A. 24" x 2" Risers (SNAPRIS-2402)
- B. 24" x 6" Risers (SNAPRIS-2406)
- C. 24" x 12" Risers (SNAPRIS-2412)
- D. 24" Lids (IMLID-2400)
- E. 24" Adapter Rings (SNAPAR-2400-2)
- F. 24" Safety Star (SNAPSAFT-2400)
- G. 24" Adapter Flange (ADF-2400)



E.



F.

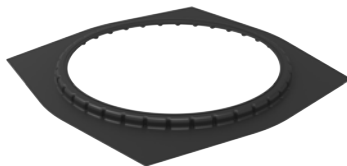

G.



WATERTIGHT GASKET TO GASKET CONNECTION

Benefits

- Easy to Assemble
- No Tools or Adhesive
- Watertight – Gasketed Connection
- Nest Together for Efficient Shipping
- Available in 2, 6 and 12 Inch Heights
- Strong, Durable, Polypropylene Construction
- Secondary Safety Lid System
- Available in Green or Black

EZsnap Riser System Sizes and Specifications

Note: Contact Infiltrator to discuss best cast practices for casting in EZsnap risers.

EZsnap Riser Specifications

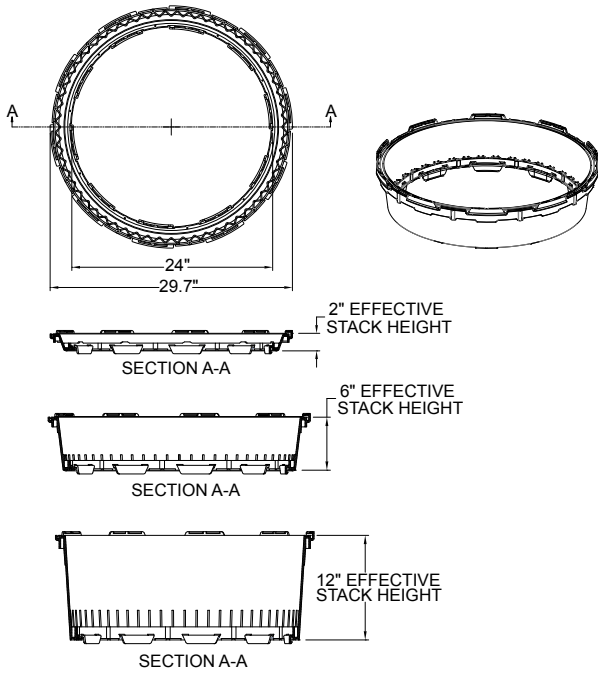

EZsnap Safety Star Specifications

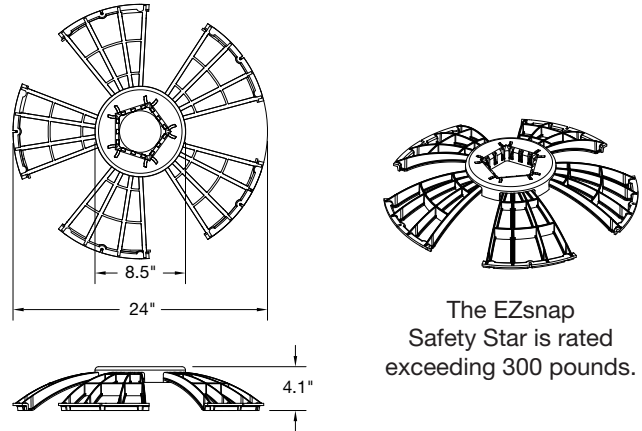

The EZsnap Safety Star is rated exceeding 300 pounds.

EZsnap Pipe Adapter Ring

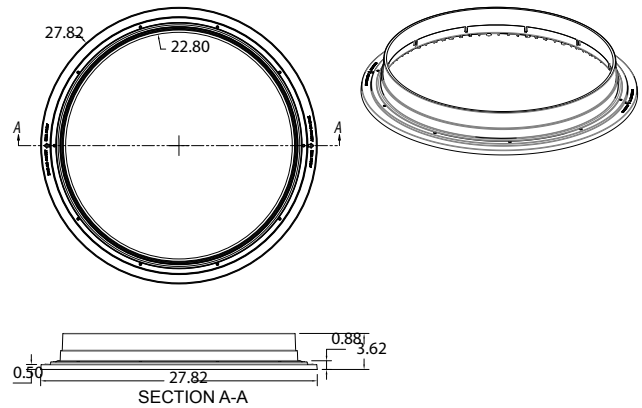

EZsnap 12" Lid Specifications

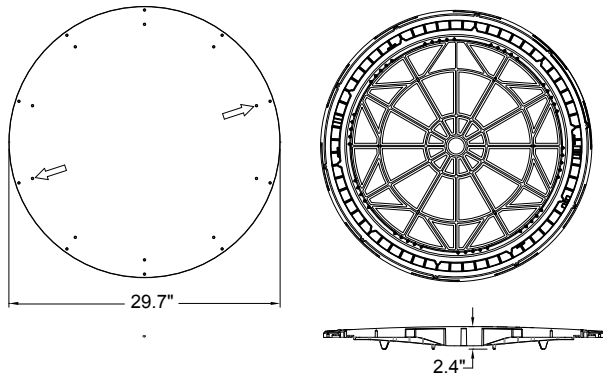

NOTE: A minimum 6-inch (150-mm) depth of suitable soil must be placed over the top of the tank. The balance of backfill placed to finish grade above the tank may be either suitable or unsuitable soil.

EZsnap Adapter Flange Specifications

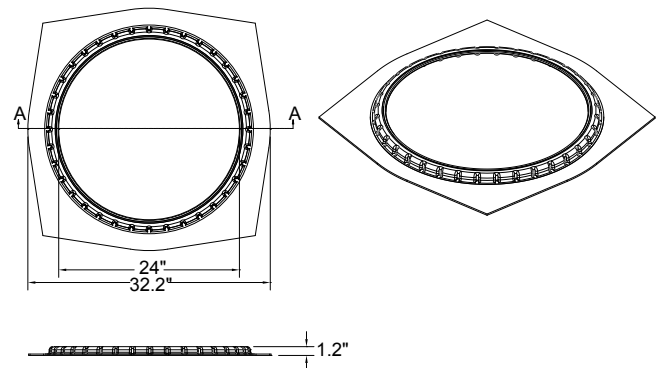

4 Business Park Road
P.O. Box 768
Old Saybrook, CT 06475
860-577-7000 • Fax 860-577-7001
1-800-221-4436
www.infiltratorwater.com

Infiltrator Water Technologies Limited Warranty

Available at: www.infiltratorwater.com
or call 1-800-221-4436

U.S. Patents: 8322948; 8337119; 8297880; 7914230; 7008138. Other patents pending. Infiltrator, Quick4 and EZflow are registered trademarks of Infiltrator Water Technologies. Infiltrator Water Technologies is a wholly-owned subsidiary of, Advanced Drainage Systems, Inc. (ADS).

© 2023 Infiltrator Water Technologies, LLC. All rights reserved. Printed in U.S.A.

EZSNAP02 0623

Contact Infiltrator Water Technologies' Technical Services Department for assistance at 1-800-221-4436