

Infiltrator Safety Star™ System

The 24" (600 mm) riser Safety Star system is a strong secondary level of protection for the EZsnap Riser System if a primary riser lid is unknowingly damaged or removed. When properly installed the Safety Star system prevents unintended entry into the tank.

(10), #14 x 2" stainless steel screws (SS1410-HEX) are provided with the EZsnap Riser System.

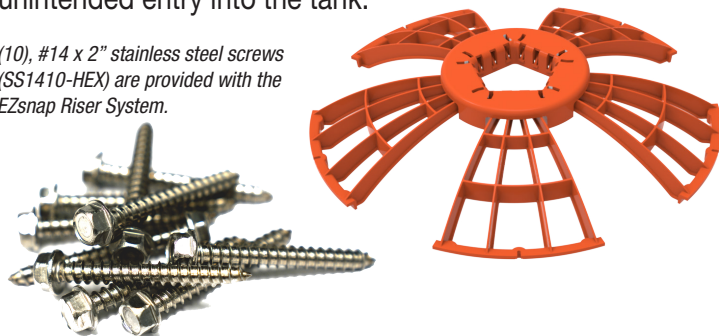

1. Install the Safety Star at the EZsnap narrow riser to riser connection closest to the ground surface. A minimum of a 6" (150 mm) riser is required to accommodate the safety star and to attach the lid properly.

2. Rotate the Safety Star until the five screw slots are aligned with the screw bosses on the riser. Fasten the Safety Star in place using five (5), #14 x 2" stainless steel screws provided (SS1410-HEX).

Note: If the Safety Star is installed at the riser-to-tank connection, the five screws used to fasten the risers to the tank also secure the Safety Star. The Safety Star is designed to allow up to a 4" (100 mm) pumping hose to enter the tank while installed, allowing for ease of maintenance without removal.

3. Five screws shall be secured tightly into place following a star pattern to complete the Safety Star installation. If the Safety Star requires removal, 5 riser-to-tank screw locations will remain fastened at all times.

4. The Infiltrator Tank Lid is then installed using all ten stainless steel screws to complete the riser installation.

Safety Star Benefits:

- Compatible with 6" (150 mm) & 12" (300 mm) EZsnap Riser models
- Structural design withstands a dead load up to 300 lbs. (136 kg)
- Installs inside the EZsnap Riser stack at any desired level
- Strong polypropylene construction
- Fastened securely in place with stainless steel hardware
- Meets regulatory requirements including CSA B66:21, as a secondary safety device
- Molded in OSHA safety orange to communicate warning

Installation

The Safety Star (SNAPSAFT-2400) is designed to be mounted to the screw pilot holes at the narrow end of the EZsnap riser connection. One arm on the Safety Star folds down 15 degrees, allowing it to collapse and fit through a 24" (600 mm) opening.

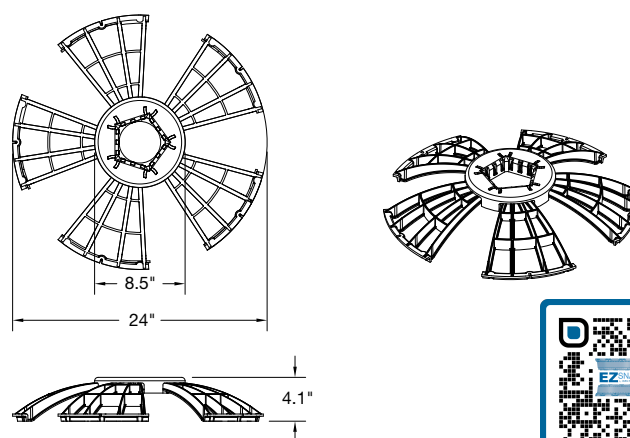

For U.S. Patents information visit www.infiltratorwater.com/patents. Other patents pending. Infiltrator, Quick4 and EZflow are registered trademarks of Infiltrator Water Technologies. Infiltrator Water Technologies is a wholly-owned subsidiary of Advanced Drainage Systems, Inc. (ADS).

© 2024 Infiltrator Water Technologies, LLC. Not responsible for any typographic errors. Printed in U.S.A.

STAR 0924

Contact Infiltrator Water Technologies' Technical Services Department for assistance at 1-800-221-4436