

The Presby Wastewater Treatment System

New Hampshire Design and Installation Manual

for
Advanced Enviro-Septic® and Enviro-Septic®
Wastewater Treatment Systems

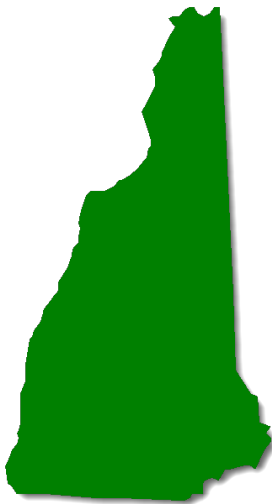

Minimizes the Expense



Protects the Environment



Preserves the Site



Presby Environmental, Inc.

An Infiltrator Water Technologies Company

The Next Generation of Wastewater Treatment Technology

143 Airport Rd., Whitefield, NH 03598

Tel: 800-473-5298 Fax: 603-837-9864

info@presbyeco.com

www.PresbyEnvironmental.com

The information in this manual is subject to change without notice. We recommend that you check your state's page on our website on a regular basis for updated information. Your suggestions and comments are welcome. Please contact us at: 800-473-5298

Presby Environmental, Inc.
143 Airport Road
Whitefield, NH 03598
Phone: 1-800-473-5298 Fax: (603) 837-9864
Website: www.PresbyEnvironmental.com

The products and methods depicted in this manual are protected by one or more patents. For more information:
www.presbyeco.com/patents

**Advanced Enviro-Septic® is a registered trademark of Presby Environmental, Inc.
Enviro-Septic® is a registered trademark of Presby Environmental, Inc.**

IMPORTANT NOTICE: This Manual is intended **ONLY** for use in designing and installing Presby Environmental's Advanced Enviro-Septic and Enviro-Septic Wastewater Treatment Systems. The use of this Manual with any other product is prohibited. The processes and design criteria contained herein are based solely on our experience with and testing of Advanced Enviro-Septic and Enviro-Septic. Substitution of any other large diameter gravelless pipe will result in compromised treatment of wastewater and other adverse effects.

This manual refers to the June 2019 Innovative/Alternative System Approval issued by the State of New Hampshire Department of Environmental Services Subsurface Bureau.
To request a copy of the approval letter, please call Presby Environmental, Inc. at 800-473-5298.

**© Presby Environmental, Inc., June 2019,
All Rights Reserved**

TABLE OF CONTENTS

<u>Section Number</u>	<u>Page Number</u>
1.0 Background.....	1
2.0 Ten Stages of Wastewater Treatment.....	2
3.0 AES and ES System Components.....	3
4.0 Tables A & B: AES and ES Pipe and Row Spacing (Single Level 1 - 60 MPI).....	5
5.0 Table C: Row Length and Pipe Layout Width (Single Level).....	5
6.0 Table D: Vertical Separation Distances to Restrictive Features (Single & Multi-Level™ Systems).....	5
7.0 Table E: Single Level versus Multi-Level™ Design Considerations.....	6
8.0 Table F & G: AES and ES Pipe and Row Spacing (Multi-Level™ 1 - 30 MPI).....	6
9.0 Table H: Row Length and Pipe Layout Width (Multi-Level™).....	6
10.0 Design Procedure and Examples.....	7
11.0 Presby Environmental Standards and Technical Support.....	9
12.0 Advanced Enviro-Septic and Enviro-Septic Sizing.....	9
13.0 Certification Requirements.....	10
14.0 Design Criteria.....	10
15.0 Basic Serial Distribution (Single Level).....	12
16.0 Basic Serial Distribution (Multi-Level™).....	13
17.0 Bottom Drain.....	14
18.0 Butterfly Configuration.....	14
19.0 Combination Serial Distribution (Single Level).....	14
20.0 Combination Serial Distribution (Multi-Level™).....	15
21.0 D-box Distribution (Single Level).....	16
22.0 Multiple Bed Distribution.....	16
23.0 Elevated Bed Systems (Mounds).....	17
24.0 In-Ground Bed Systems.....	17
25.0 Non-Conventional System Configurations.....	17
26.0 H-20 Wheel Loading.....	17
27.0 Pumped System Requirements.....	18
28.0 System Sand and Sand Fill Requirements for All Beds.....	18
29.0 Venting Requirements.....	19
30.0 Site Selection.....	21
31.0 Installation Requirements, Component Handling and Site Preparation.....	22
32.0 System Bacteria Rejuvenation.....	23
33.0 Operation & Maintenance.....	24
34.0 Glossary.....	25
35.0 System Diagrams.....	29

1.0 Background

Liquid that exits from a septic tank (“effluent”) contains suspended solids that can cause traditional systems to fail prematurely. Solids can overload bacteria, cut off air required for aerobic bacterial activity, and/or seal the underlying soil, interfering with its ability to absorb liquid.

1.1 What Our System Does

By utilizing simple yet effective natural processes, the Presby Treatment System treats septic tank effluent in a manner that prevents suspended solids from sealing the underlying soil, increases system aeration, and provides a greater bacterial treatment area (“biomat”) than traditional systems.

1.2 Why Our System Excels

The Presby Treatment System retains solids in its pipe and provides multiple bacterial surfaces to treat effluent prior to its contact with the soil. The continual cycling of effluent (the rising and falling of liquid inside the pipe) enhances bacterial growth. This all combines to create a unique eco-system that no other passive wastewater treatment system is designed to offer. The result is a system that excels by being more efficient, lasting longer, and having a minimal environmental impact.

1.3 System Advantages

- a) costs less than traditional systems
- b) eliminates the need for washed stone
- c) often requires a smaller area
- d) installs more easily and quickly than traditional systems
- e) adapts easily to residential and commercial sites of virtually any size
- f) adapts well to difficult sites
- g) develops a protected receiving surface preventing sealing of the underlying soil
- h) blends “septic mounds” into sloping terrain
- i) increases system performance and longevity
- j) tests environmentally safer than traditional systems
- k) recharges groundwater more safely than traditional systems
- l) made from recycled plastic

1.4 Patented Presby Technology

At the heart of Advanced Enviro-Septic (AES) and Enviro-Septic (ES) pipe is a patented corrugated, perforated plastic pipe with interior skimmer tabs and cooling ridges. All AES and ES pipe is surrounded by one or more filtering, treatment and dispersal layers. Presby Systems are completely passive, requiring no electricity, motors, alarms, computers, etc. AES and ES pipes are assembled and installed in a bed of specified System Sand which can either be below the ground or above.

1.5 Advanced Enviro-Septic® (AES)

The Advanced Enviro-Septic pipe is assembled into an onsite wastewater treatment system that has been successfully tested and certified to NSF 40, Class I (a certification typically given to mechanical aeration devices), BNQ of Quebec, Class I, II, III and Cebedeau, Belgium standards. Advanced Enviro-Septic is comprised of corrugated, perforated plastic pipe, Bio-Accelerator fabric along its bottom which is surrounded by a layer of randomized plastic fibers and a sewn geo-textile fabric. Advanced Enviro-Septic creates an eco-system designed to simultaneously purify and disperse effluent after primary treatment by a septic tank. Advanced Enviro-Septic is the “next generation” of our Enviro-Septic technology. The AES product incorporates Bio-Accelerator®, a proprietary enhancement that screens additional solids from effluent, accelerates treatment processes, assures even distribution and provides additional surface area. Each foot of Advanced Enviro-Septic pipe provides over 40 sq. ft. of total surface area for bacterial activity.

1.6 Enviro-Septic® (ES)

The Enviro-Septic pipe is assembled into an onsite wastewater treatment system. Enviro-Septic is comprised of corrugated, perforated plastic pipe which is surrounded by a layer of randomized plastic fibers and a sewn geo-textile fabric. The system is designed to simultaneously purify and disperse effluent after primary treatment by a septic tank. Each foot of Enviro-Septic pipe provides over 25 sq. ft. of total surface area for bacterial activity.

2.0 Ten Stages of Wastewater Treatment

The Presby Wastewater Treatment System's 10 STAGES OF TREATMENT

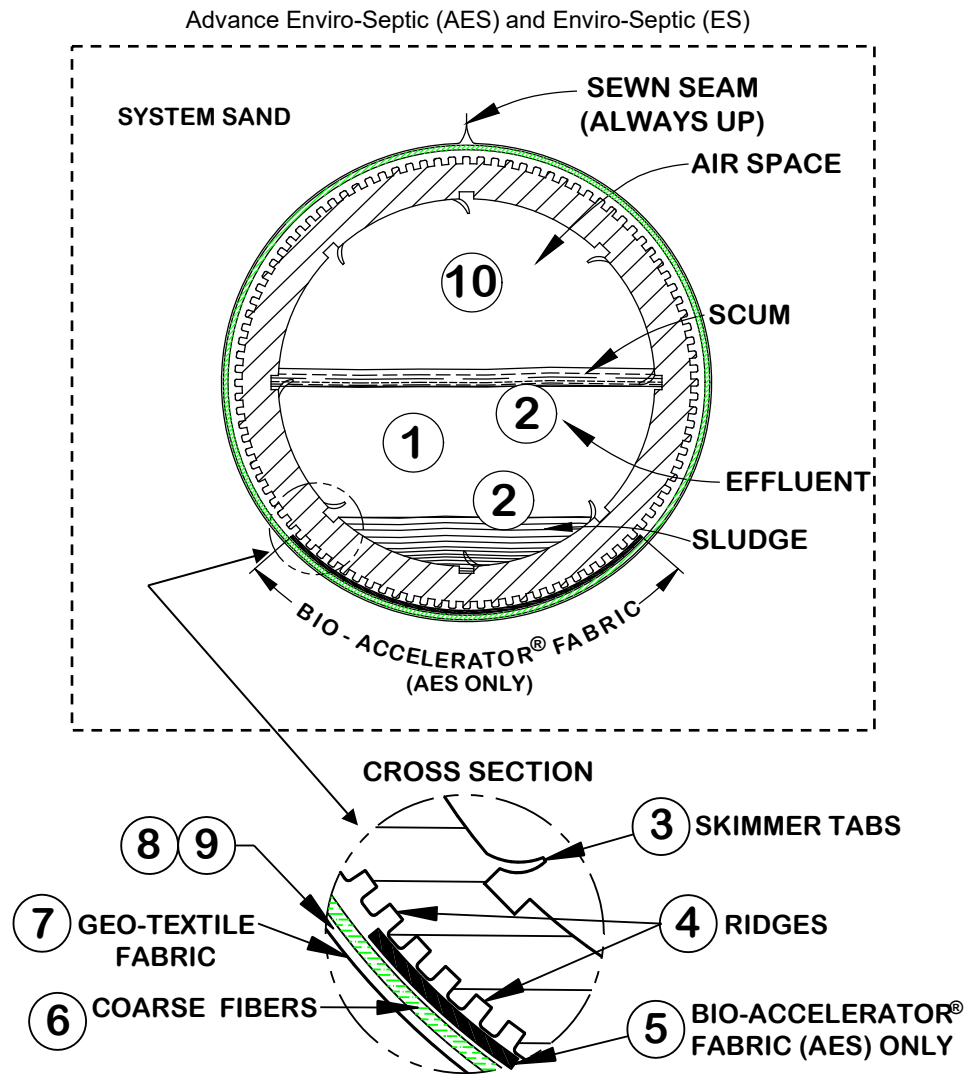

- Stage 1:** Warm effluent enters the pipe and is cooled to ground temperature.
- Stage 2:** Suspended solids separate from the cooled liquid effluent.
- Stage 3:** Skimmers further capture grease and suspended solids from the existing effluent.
- Stage 4:** Pipe ridges allow the effluent to flow uninterrupted around the circumference of the pipe and aid in cooling.
- Stage 5:** Bio-Accelerator fabric screens additional solids from the effluent, enhances and accelerates treatment, facilitates quick start-up after periods of non-use, provides additional surface area for bacterial growth, promotes even distribution, and further protects outer layers and the receiving surfaces so they remain permeable (AES only).
- Stage 6:** A mat of coarse, randomly-oriented fibers separates more suspended solids from the effluent.
- Stage 7:** Effluent passes into the geo-textile fabrics and grows a protected bacterial surface.
- Stage 8:** Sand wicks liquid from the geo-textile fabrics and enables air to transfer to the bacterial surface.
- Stage 9:** The fabrics and fibers provide a large bacterial surface to break down solids.
- Stage 10:** An ample air supply and fluctuating liquid levels increase bacterial efficiency.

3.0 AES and ES System Components

3.1 Advanced Enviro-Septic and Enviro-Septic Pipe

- a) Single & Multi-Level™: quantity of pipe is determined by using Table A.
- b) Plastic pipe made with a significant percentage of recycled material
- c) 10-ft. sections (can be cut to any length)
- d) Ridged and perforated, with skimmer tabs on interior
- e) AES only: Bio-Accelerator fabric along bottom of pipe (sewn seam is always placed up).
- f) Surrounded by a mat of randomly oriented plastic fibers
- g) Wrapped in a non-woven geo-textile fabric stitched in place
- h) Exterior diameter of 12-in.
- i) Each 10-ft. section has a liquid holding capacity of approximately 58 gallons
- j) A 10-ft. length of AES or ES pipe is flexible enough to bend up to 90°



3.2 Offset Adapter

An offset adapter is a plastic fitting 12-in. in diameter with an inlet hole designed to accept a 4-in. sewer line, raised connection or vent pipe. The hole is to be installed in the 12 o'clock position. The distance from the bottom of the Offset Adapter to the bottom of its inlet hole is 7-in. When assembling pipes into rows, note that the geo-textile fabrics are placed over the edges of the Offset Adapter and Couplings.



3.3 Double Offset Adapter

A double offset adapter is a plastic fitting 12-in. in diameter with two 4-in. holes designed to accept a 4-in. inlet pipe, raised connection, vent or vent manifold, and/or bottom drain, depending upon the particular requirements of the design configuration. The 4-in. holes are to be aligned in the 12 o'clock and 6 o'clock positions. The holes are positioned 1-in. from the outside edge of the double offset adaptor and 2-in. from each other.



3.4 Coupling

A coupling is a plastic fitting used to create a connection between two pieces of pipe. Note that the couplings are wide enough to cover 1 or 2 pipe corrugations on each of the two pipe ends being joined. The couplings feature a snap-lock feature that requires no tools. When assembling pipes into rows, note that the geo-textile fabric does not go under couplings. Pull fabric back, install coupling, and then pull fabric over coupling. Also note, during installation in cold weather, couplings are easier to work with if stored in a heated location (such as a truck cab) before use.



3.5 Distribution Box

A Distribution Box, also called a "D-box," is a device used to distribute effluent coming from the septic tank in a system that contains more than one section, multiple rows or more than one bed. D-boxes are also sometimes used for velocity reduction. D-boxes come in various sizes and with a varying number of outlets. Concrete D-boxes are preferred; some are made of plastic. Flow equalizers (shown below) are installed in the D-box openings to equalize distribution; they help ensure equal distribution in the event that the D-box settles or otherwise becomes out of level. Unused openings in D-boxes are to be covered, plugged or mortared. A distribution box is only required when pumping or dividing flow to more than one section or row of the bed (see para. 27.0, pg. 18 for pump systems). Four-inch diameter plastic pipe, equivalent to Schedule 40 or SDR 35, is recommended for connecting the D-box to the AES or ES pipes, however Sewer and Drain pipe may be used. Glue or screw all connections.

3.6 Flow Equalizers

All Presby Systems that divide flow (as do Combination Serial distribution, D-box distribution, Butterfly configuration or Multiple Bed distribution systems) must use Flow Equalizers in each distribution box outlet. A Flow Equalizer is an adjustable plastic insert installed in the outlet holes of a distribution box to equalize effluent distribution to each outlet whenever flow is divided. Each Bed or section of Combination Serial distribution is limited to a maximum of 20 gallons per minute, due to the flow constraints of the equalizers. Example: pumping to a combination system with 3 sections (using 3 D-box outlets). The maximum delivery rate is $(3 \times 20) = 60$ GPM. Always provide a means of velocity reduction when needed.



3.7 Manifolded Splitter Box

A manifolded splitter box joins several outlets of a D-box to help divide flow more accurately. Dividing flow to multiple beds is a common use of splitter boxes. All outlets delivering effluent to the field must have a flow equalizer. Do not place an equalizer on vent outlets.

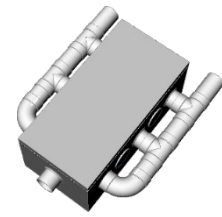

3.8 Raised Connection

A raised connection is a PVC Sewer & Drain pipe configuration which is used to connect pipe rows. Raised connections extend 2-in. to 4-in. into pipe and are installed on an angle (as shown below). All PVC joints should be glued or mechanically fastened.

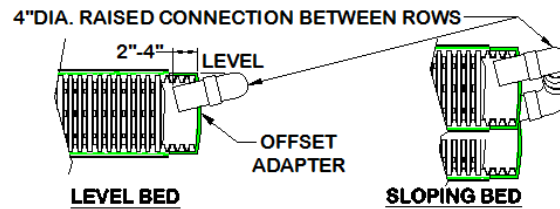

3.9 Raised Straight Connection

A raised straight connection is a PVC Sewer & Drain pipe configuration which is used to connect pipe rows that are placed end to end along the same contour. Raised straight connections extend 2-in. to 4-in. into pipe and are installed on an angle (as shown below). All PVC joints should be glued or mechanically fastened. Offset Adapters will accept 4-inch schedule 40 PVC if the edge of the adapter is rounded.

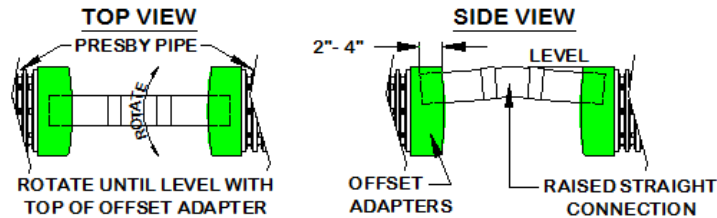

3.10 Septic Tank

- a) The AES or ES system is designed to treat effluent that has received “primary treatment” in a standard septic tank. Septic tank capacity should be in accordance with NH’s Subsurface Rules. Septic tanks used with the system must be fitted with inlet and outlet baffles in order to retain solids in the septic tank and to prevent them from entering the AES or ES pipes.
- b) Effluent filters are not recommended by Presby Environmental, Inc. due to their restrictive characteristics and tendency to clog, which cuts off the oxygen supply that is essential to the functioning of the system. If an effluent filter is used in a gravity fed system, the effluent filter selected must allow for the free passage of air through the septic tank and be cleaned regularly to help ensure the wastewater treatment system functions properly.

3.11 System Sand

System Sand must be clean, granular sand free of organic matter and must adhere to the following percentage and quality restrictions:

System Sand Specification	
Sieve Size	Percent Retained on Sieve (by weight)
3/4 in. (19 mm)	0
#10 (2 mm)	0 - 35
#35 (0.50 mm)	40 - 90
Note: not more than 3% allowed to pass the #200 sieve (verified by washing sample per requirements of ASTM C-117)	

3.12 System Sand Acceptable Alternative

ASTM C-33 (concrete sand), natural or manufactured sand, with not more than 3% passing the #200 sieve (verified by washing the sample per the requirements of ASTM C-117 as noted in the ASTM C-33 specification) may be used as an acceptable alternate material for use as System Sand.

4.0 Tables A & B: AES and ES Pipe and Row Spacing (Single Level 1 - 60 MPI)

Table A: Pipe Required Min. (Single Level)

Perc. Rate MPI	Number of Bedrooms						Commercial Per 100 GPD
	2	3	4	5	6	Add'l Room	
1 - 2	140	210	280	350	420	70	47
3 - 4	140	210	280	350	420	70	47
5 - 6	140	210	280	350	420	70	50
7 - 9	140	210	280	350	420	70	55
10 - 13	140	210	280	350	420	70	60
14 - 19	140	210	280	350	420	70	66
20 - 30	140	210	280	350	420	70	71
31 - 40	140	210	280	350	420	70	77
41 - 50	150	225	300	375	450	75	83
51 - 60	160	240	320	400	480	80	89

* Pipe Required Minimum (ft.)

Ex: 4 Bedrooms @ 7 MPI requires 280 ft. of pipe. Consult factory for high strength wastewater (see para. 14.18, pg. 12).

Table B: Row Spacing Min. (Single Level)

Percentage of System Slope	Percolation Rate					
	1-10	11-20	21-30	31-40	41-50	51 to 60
0 - 10%	1.50	1.50	1.75	2.00	2.50	3.00
11 - 15%	1.50	1.75	2.00	2.25	2.75	3.25
16 - 20%	1.75	2.00	2.25	2.50	3.00	3.50
21 - 25%	2.00	2.25	2.50	2.75	3.25	3.75

Center-to-Center Row Spacing Minimum (ft.)

Ex: System Slope of 10% or less @ 7 MPI requires row spacing of 1.5 ft. min.

5.0 Table C: Row Length and Pipe Layout Width (Single Level)

		Total Linear Feet of AES or ES Pipe														
Row Length (ft.)	# of Rows	2	3	4	5	6	7	8	9	10	11	12	13	14	15	
	20	20	40	60	80	100	120	140	160	180	200	220	240	260	280	300
	25	25	50	75	100	125	150	175	200	225	250	275	300	325	350	375
	30	30	60	90	120	150	180	210	240	270	300	330	360	390	420	450
	35	35	70	105	140	175	210	245	280	315	350	385	420	455	490	525
	40	40	80	120	160	200	240	280	320	360	400	440	480	520	560	600
	45	45	90	135	180	225	270	315	360	405	450	495	540	585	630	675
	50	50	100	150	200	250	300	350	400	450	500	550	600	650	700	750
	55	55	110	165	220	275	330	385	440	495	550	605	660	715	770	825
	60	60	120	180	240	300	360	420	480	540	600	660	720	780	840	900
	65	65	130	190	260	325	390	455	520	585	650	715	780	845	910	975
	70	70	140	210	280	350	420	490	560	630	700	770	840	910	980	1050
	75	75	150	225	300	375	450	525	600	675	750	825	900	975	1050	1125
	80	80	160	240	320	400	480	560	640	720	800	880	960	1040	1120	1200
	85	85	170	255	340	425	510	595	680	765	850	935	1020	1105	1190	1275
	90	90	180	270	360	450	540	630	720	810	900	990	1080	1170	1260	1350
95	95	190	285	380	475	570	665	760	855	950	1045	1140	1235	1330	1425	
100	100	200	300	400	500	600	700	800	900	1000	1100	1200	1300	1400	1500	
Row Spacing Minimum (ft.)	# of Rows	2	3	4	5	6	7	8	9	10	11	12	13	14	15	
	1.50	1.50	2.50	4.00	5.50	7.00	8.50	10.00	11.50	13.00	14.50	16.00	17.50	19.00	20.50	22.00
	1.75	1.75	2.75	4.50	6.25	8.00	9.75	11.50	13.25	15.00	16.75	18.50	20.25	22.00	23.75	25.50
	2.00	2.00	3.00	5.00	7.00	9.00	11.00	13.00	15.00	17.00	19.00	21.00	23.00	25.00	27.00	29.00
	2.25	2.25	3.25	5.50	7.75	10.00	12.25	14.50	16.75	19.00	21.25	23.50	25.75	28.00	30.25	32.50
	2.50	2.50	3.50	6.00	8.50	11.00	13.50	16.00	18.50	21.00	23.50	26.00	28.50	31.00	33.50	36.00
	2.75	2.75	3.75	6.50	9.25	12.00	14.75	17.50	20.25	23.00	25.75	28.50	31.25	34.00	36.75	39.50
	3.00	3.00	4.00	7.00	10.00	13.00	16.00	19.00	22.00	25.00	28.00	31.00	34.00	37.00	40.00	43.00
	3.25	3.25	4.25	7.50	10.75	14.00	17.25	20.50	23.75	27.00	30.25	33.50	36.75	40.00	43.25	46.50
	3.50	3.50	4.50	8.00	11.50	15.00	18.50	22.00	25.50	29.00	32.50	36.00	39.50	43.00	46.50	50.00
	3.75	3.75	4.75	8.50	12.25	16.00	19.75	23.50	27.25	31.00	34.75	38.50	42.25	46.00	49.75	53.50
4.00	4.00	5.00	9.00	13.00	17.00	21.00	25.00	29.00	33.00	37.00	41.00	45.00	49.00	53.00	57.00	
4.25	4.25	5.25	9.50	13.75	18.00	22.25	26.50	30.75	35.00	39.25	43.50	47.75	52.00	56.25	60.50	
4.50	4.50	5.50	10.00	14.50	19.00	23.50	28.00	32.50	37.00	41.50	46.00	50.50	55.00	59.50	64.00	
4.75	4.75	5.75	10.50	15.25	20.00	24.75	29.50	34.25	39.00	43.75	48.50	53.25	58.00	62.75	67.50	
5.00	5.00	6.00	11.00	16.00	21.00	26.00	31.00	36.00	41.00	46.00	51.00	56.00	61.00	66.00	71.00	

Pipe Layout Width ft.

Ex: select a row length and move right until the minimum amount of pipe is found (more is allowed). Then move down to find the number of rows required; continue downward in the same column to find the pipe layout width for your spacing.

6.0 Table D: Vertical Separation Distances to Restrictive Features (Single & Multi-Level™ Systems)

Pipe Model	S.H.W.T. (In.)		Impermeable Layer (In.)
	600 GPD or Less	Over 600 GPD	
Advanced Enviro-Septic	24	30	30
Enviro-Septic	30	30	30

All measurements to bottom of AES or ES Pipe.

7.0 Table E: Single Level versus Multi-Level™ Design Considerations

Pipe Model	Single Level System				Multi-Level™ System			
	Perc Rate MPI	Venting Required	Pipe Required	Row Spacing	Perc Rate MPI	Venting Required	Pipe Required	Row Spacing
Advanced Enviro-Septic	1 - 60	Yes	Table A	Table B	1 - 30	Yes	Table F	Table G
Enviro-Septic		* No				Yes		

*ES does require venting with more than 18" of cover over pipes and/or when pumping to the field.

8.0 Table F & G: AES and ES Pipe and Row Spacing (Multi-Level™ 1 - 30 MPI)

Table F: Pipe Required Minimum (Multi-Level™)

Perc Rate MPI	Number of Bedrooms						Commercial Per 100 GPD
	2	3	4	5	6	Add'l Room	
1-2	140	210	280	350	420	70	47
3-4	140	210	280	350	420	70	52
5-6	140	210	280	350	420	70	55
7-9	140	210	280	350	420	70	61
10-13	140	210	280	350	420	70	66
14-19	140	210	280	350	420	70	73
20-30	143	215	286	358	429	72	79

* Presby Pipe Required Minimum (ft.)

Table G: Row Spacing Minimum (Multi-Level™)

Percentage of System Slope	Percolation Rate (MPI)		
	1-10	11-20	21-30
0-10%	1.50	1.75	2.00
11-15%	1.75	2.00	2.25
16-20%	2.00	2.25	2.50
21-25%	2.25	2.50	2.75

Center-to-Center Row Spacing Minimum (ft.)

Ex: A System Slope of 10% or less with a 6 MPI perc. rate requires pipe spacing of 1.5 ft.

Ex: 4 Bedrooms @ 7 MPI requires 280 ft. of Pipe. Consult factory for high strength wastewater (see para. 14.18, pg. 12).

9.0 Table H: Row Length and Pipe Layout Width (Multi-Level™)

		Total Linear Feet of AES or ES Pipe														
Row Length (ft.)	30	60	90	120	150	180	210	240	270	300	330	360	390	420	450	
	35	70	105	140	175	210	245	280	315	350	385	420	455	490	525	
	40	80	120	160	200	240	280	320	360	400	440	480	520	560	600	
	45	90	135	180	225	270	315	360	405	450	495	540	585	630	675	
	50	100	150	200	250	300	350	400	450	500	550	600	650	700	750	
	55	110	165	220	275	330	385	440	495	550	605	660	715	770	825	
	60	120	180	240	300	360	420	480	540	600	660	720	780	840	900	
	65	130	195	260	325	390	455	520	585	650	715	780	845	910	975	
	70	140	210	280	350	420	490	560	630	700	770	840	910	980	1050	
	75	150	225	300	375	450	525	600	675	750	825	900	975	1050	1125	
	80	160	240	320	400	480	560	640	720	800	880	960	1040	1120	1200	
	85	170	255	340	425	510	595	680	765	850	935	1020	1105	1190	1275	
90	180	270	360	450	540	630	720	810	900	990	1080	1170	1260	1350		
95	190	285	380	475	570	665	760	855	950	1045	1140	1235	1330	1425		
100	200	300	400	500	600	700	800	900	1000	1100	1200	1300	1400	1500		
# of Rows	2	3	4	5	6	7	8	9	10	11	12	13	14	15		
Center-to-Center Row Spacing in ft.	1.50	1.75	2.50	3.25	4.00	4.75	5.50	6.25	7.00	7.75	8.50	9.25	10.00	10.75	11.50	
	1.75	1.88	2.75	3.63	4.50	5.38	6.25	7.13	8.00	8.88	9.75	10.63	11.50	12.38	13.25	
	2.00	2.00	3.00	4.00	5.00	6.00	7.00	8.00	9.00	10.00	11.00	12.00	13.00	14.00	15.00	
	2.25	2.13	3.25	4.38	5.50	6.63	7.75	8.88	10.00	11.13	12.25	13.38	14.50	15.63	16.75	
	2.50	2.25	3.50	4.75	6.00	7.25	8.50	9.75	11.00	12.25	13.50	14.75	16.00	17.25	18.50	
	2.75	2.38	3.75	5.13	6.50	7.88	9.25	10.63	12.00	13.38	14.75	16.13	17.50	18.88	20.25	
	3.00	2.50	4.00	5.50	7.00	8.50	10.00	11.50	13.00	14.50	16.00	17.50	19.00	20.50	22.00	
	3.25	2.63	4.25	5.88	7.50	9.13	10.75	12.38	14.00	15.63	17.25	18.88	20.50	22.13	23.75	
	3.50	2.75	4.50	6.25	8.00	9.75	11.50	13.25	15.00	16.75	18.50	20.25	22.00	23.75	25.50	
	3.75	2.88	4.75	6.63	8.50	10.38	12.25	14.13	16.00	17.88	19.75	21.63	23.50	25.38	27.25	
	4.00	3.00	5.00	7.00	9.00	11.00	13.00	15.00	17.00	19.00	21.00	23.00	25.00	27.00	29.00	
4.25	3.13	5.25	7.38	9.50	11.63	13.75	15.88	18.00	20.13	22.25	24.38	26.50	28.63	30.75		
4.50	3.25	5.50	7.75	10.00	12.25	14.50	16.75	19.00	21.25	23.50	25.75	28.00	30.25	32.50		
4.75	3.38	5.75	8.13	10.50	12.88	15.25	17.63	20.00	22.38	24.75	27.13	29.50	31.88	34.25		
5.00	3.50	6.00	8.50	11.00	13.50	16.00	18.50	21.00	23.50	26.00	28.50	31.00	33.50	36.00		

* Pipe Layout Width (Outermost edge of Upper Level to Outmost edge of Lower Level)

* Formula for Multi-Level™ Pipe Layout Width (3 rows or more) = { [Row Spacing x (# of Rows - 1)] / 2 } + 1

10.0 Design Procedure and Examples

- Step #1:** For normal strength effluent find the minimum amount of AES or ES pipe required from Table A (single level bed) or Table F (Multi-Level™ bed) for the daily design flow. Contact Presby Environmental for high strength wastewater recommendations.
- Step #2:** Using the system slope and perc rate find the minimum row spacing from Table B (single level) or Table G (Multi-Level™).
- Step #3:** Calculate the minimum number of serial sections required (does not apply to Parallel configuration): divide the daily design flow by 500 GPD if over 900 GPD (if answer is fractional, round up to nearest whole number). Ex: 1,000 GPD ÷ 500 GPD/section = 2 sections. Note: a 900 GPD system is not more than 900 GPD so it is not subject to this rule.
- Step #4:** Select a row length that is suitable for the site and calculate the number of rows required by dividing the pipe required (Step #1) by the row length. When using serial distribution all rows do not have to be the same length. However, Parallel distribution does require all rows be of equal length. The number of rows must be evenly divisible by the number of serial sections required (add rows as necessary).
- Step #5:** Find the Pipe Layout Width (PLW) from Table C for single level beds or Table H for a Multi-Level™ systems using the center-to-center row spacing from Step #2 (larger spacing allowed).
- Step #6:** Determine if a System Sand Extension is required. If the System Slope is greater than 10%, a 3 ft. extension is required entirely on the down slope side of the field.

10.1 Design Example #1: Single Family Residence, (3) bedrooms (450 GPD), 14 MPI perc rate, and design for a 10% Single Level sloping system as an elevated serial distribution bed.

Step #1: Pipe required from Table A = 210 ft. min.

Perc. Rate MPI	Number of Bedrooms					Add'l Room
	2	3	4	5	6	
1 - 2	140	210	280	350	420	70
3 - 4	140	210	280	350	420	70
5 - 6	140	210	280	350	420	70
7 - 9	140	210	280	350	420	70
10 - 13	140	210	280	350	420	70
14 - 19	140	210	280	350	420	70
20 - 30	140	210	280	350	420	70
31 - 40	140	210	280	350	420	70
41 - 50	150	225	300	375	450	75
51 - 60	160	240	320	400	480	80

* Presby Pipe Required Minim

Step #2: Table B: minimum row spacing = 1.50 ft.

Percentage of System Slope	Percolation Rate					
	1-10	11-20	21-30	31-40	41-50	51 to 60
0 - 10%	1.50	1.50	1.75	2.00	2.50	3.00
11 - 15%	1.50	1.75	2.00	2.25	2.75	3.25
16 - 20%	1.75	2.00	2.25	2.50	3.00	3.50
21 - 25%	2.00	2.25	2.50	2.75	3.25	3.75

Center-to-Center Row Spacing Minimum (ft.)

Step #3: Serial sections required → 450 GPD is not greater than 900 GPD, so only one serial section is required.

Step #4: Using a 70 ft. row length will require 3 rows (210 ft. ÷ 70 ft.)

Step #5: The pipe layout width for three 70 ft. rows spaced 1.5 ft. apart from Table C is 4 ft. This is the distance from the outermost edge of the first row to the outermost edge of the last row.

Table C: Row Length and Pipe Layout Width (Single Level)

		Total Linear Feet of Presby Pipe														
		20	40	60	80	100	120	140	160	180	200	220	240	260	280	300
Row Length (ft.)	50	100	150	200	250	300	350	400	450	500	550	600	650	700	750	
	55	110	165	220	275	330	385	440	495	550	605	660	715	770	825	
	60	120	180	240	300	360	420	480	540	600	660	720	780	840	900	
	65	130	190	260	325	390	455	520	585	650	715	780	845	910	975	
	70	140	210	280	350	420	490	560	630	700	770	840	910	980	1050	
	75	150	225	300	375	450	525	600	675	750	825	900	975	1050	1125	
	80	160	240	320	400	480	560	640	720	800	880	960	1040	1120	1200	
	85	170	255	340	425	510	595	680	765	850	935	1020	1105	1190	1275	
	90	180	270	360	450	540	630	720	810	900	990	1080	1170	1260	1350	
	95	190	285	380	475	570	665	760	855	950	1045	1140	1235	1330	1425	
	100	200	300	400	500	600	700	800	900	1000	1100	1200	1300	1400	1500	
	# of Rows	1.50	2.50	4.00	5.50	7.00	8.50	10.00	11.50	13.00	14.50	16.00	17.50	19.00	20.50	22.00
	(ft.)	1.75	2.75	4.50	6.25	8.00	9.75	11.50	13.25	15.00	16.75	18.50	20.25	22.00	23.75	25.50
		2.00	3.00	5.00	7.00	9.00	11.00	13.00	15.00	17.00	19.00	21.00	23.00	25.00	27.00	29.00
		2.25	3.25	5.50	7.75	10.00	12.25	14.50	16.75	19.00	21.25	23.50	25.75	28.00	30.25	32.50
2.50		3.50	6.00	8.25	10.50	12.75	15.00	17.25	19.50	21.75	24.00	26.25	28.50	30.75	33.00	
2.75		3.75	6.50	8.75	11.00	13.25	15.50	17.75	20.00	22.25	24.50	26.75	29.00	31.25	33.50	
		4.75	5.75	10.50	15.25	20.00	24.75	29.50	34.25	39.00	43.75	48.50	53.25	58.00	62.75	67.50
		5.00	6.00	11.00	16.00	21.00	26.00	31.00	36.00	41.00	46.00	51.00	56.00	61.00	66.00	71.00

Pipe Layout Width ft.

Step #6: This system will slope only 10%, so no system sand extension is required.

Illustration of Example #1, Basic Serial Distribution:

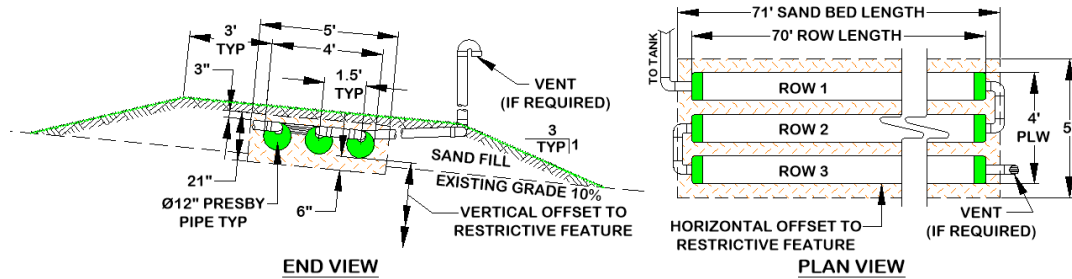

10.2 Design Example #2: Single Family Residence, (7) bedrooms (1,050 GPD), 25 MPI perc rate, design for a 12% Single Level sloping system as an elevated bed using serial distribution.

Step #1: Pipe required for 7 bedrooms from Table A = 490 ft. min (420 ft. + 70 ft.)

Perc. Rate MPI	Number of Bedrooms					Add'l Room
	2	3	4	5	6	
1 - 2	140	210	280	350	420	70
3 - 4	140	210	280	350	420	70
5 - 6	140	210	280	350	420	70
7 - 9	140	210	280	350	420	70
10 - 13	140	210	280	350	420	70
14 - 19	140	210	280	350	420	70
20 - 30	140	210	280	350	420	70
31 - 40	140	210	280	350	420	70
41 - 50	150	225	300	375	450	75
51 - 60	160	240	320	400	480	80

Step #2: Minimum row spacing for 25 MPI sloping 12% from Table B is 2 ft.

Percentage of System Slope	Percolation Rate					
	1-10	11-20	21-30	31-40	41-50	51 to 60
0 - 10%	1.50	1.50	1.75	2.00	2.50	3.00
11 - 15%	1.50	1.75	2.00	2.25	2.75	3.25
16 - 20%	1.75	2.00	2.25	2.50	3.00	3.50
21 - 25%	2.00	2.25	2.50	2.75	3.25	3.75

Center-to-Center Row Spacing Minimum (ft.)

Step #3: Serial sections required → 1,050 GPD ÷ 500 GPD/section = 2.1, round up to 3 sections.

Step #4: The site will accommodate a row length of 85 ft. This requires 6 rows (490 ft. ÷ 85 ft. = 5.76, round up to 6). Six rows are also evenly divided by the required 3 serial sections, so there will be 2 rows per section.

Step #5: The pipe layout width for six 85 ft. rows spaced 2 ft. apart from Table C is 11 ft. This is the distance from the outermost edge of the first row to the outermost edge of the last row.

Row Length (ft.)	Row Length and Pipe Layout Width (Sin Total)					
	20	40	60	80	100	120
25	50	75	100	125	150	175
30	60	90	120	150	180	210
35	70	105	140	175	210	245
40	80	120	160	200	240	280
45	90	135	180	225	270	315
50	100	150	200	250	300	350
55	110	165	220	275	330	385
60	120	180	240	300	360	420
65	130	195	260	325	390	455
70	140	210	280	350	420	490
75	150	225	300	375	450	525
80	160	240	320	400	480	560
85	170	255	340	425	510	595
90	180	270	360	450	540	630
95	190	285	380	475	570	665
100	200	300	400	500	600	700
# of Rows	2	3	4	5	6	7
1.50	2.50	4.00	5.50	7.00	8.50	10.00
1.75	2.75	4.50	6.25	8.00	9.75	11.50
2.00	3.00	5.00	7.00	9.00	11.00	13.00
2.25	3.25	5.50	7.75	10.00	12.25	14.50
2.50	3.50	6.00	8.50	11.00	13.50	16.00

Step #6: This system will slope over 10%, so a 3 ft. system sand extension is required on the down slope side of the field (see illustration on below).

Illustration of Example #2, (Plan View):

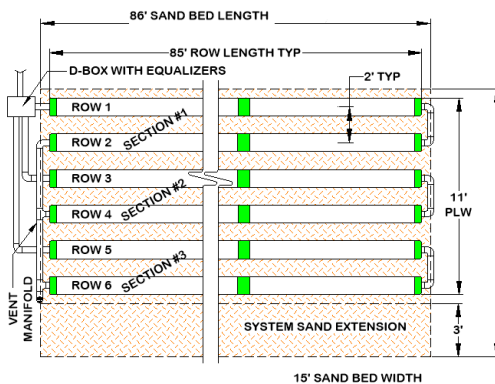

End View illustration of Example #2 (distribution box not shown):

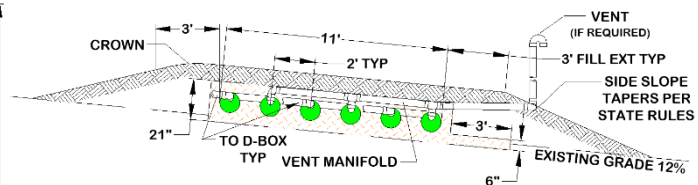

10.3 Design Example #3: Commercial System, Design criteria: daily design flow =1,500 GPD, 30 MPI percolation rate, design for a level site using a Multi-Level™ configuration.

Step #1: Pipe required for 1,500 GPD from Table F = 1,185 ft. min (1,500/ 100 x 79 ft)

Step #2: Minimum row spacing for 30 MPI, level bed from Table G is 2 ft.

Perc Rate MPI	Number of Bedrooms						* Commercial Per 100 GPD
	2	3	4	5	6	Add'l Room	
1-2	140	210	280	350	420	70	50
3-4	140	210	280	350	420	70	52
5-6	140	210	280	350	420	70	55
7-9	140	210	280	350	420	70	61
10-13	140	210	280	350	420	70	66
14-19	140	210	280	350	420	70	73
20-30	140	210	280	350	420	70	79

* Presby Pipe Required Minimum (ft.)

Percentage of System Slope	Percolation Rate (MPI)		
	1-10	11-20	21-30
0-10%	1.75	2.00	2.25
11-15%	1.75	2.00	2.25
16-20%	2.00	2.25	2.50
21-25%	2.25	2.50	2.75

Center-to-Center Row Spacing Minimum (ft.)

Step #3: Serial sections required → 1,500 GPD ÷ 500 GPD/section = 3 sections minimum (4 used for this example).

Step #4: The site will accommodate a row length of 100 ft. This requires 12 rows (1,185 ft. ÷ 100 ft) There will be six rows in the Upper Level and six rows in the Lower Level

Step #5: The pipe layout width for twelve 100 ft. rows spaced 2 ft. apart from Table H is 12 ft. This is the distance from the outermost edge of the first row in the Upper Level to the outermost edge of the last row in the Lower Level. This can be verified by using the formula shown at the bottom of Table H.
 Multi-Level™ PLW = { [2 ft. spacing x (12 Rows - 1)] / 2 } + 1 = 12 ft.

Step #6: This system will be constructed level, so there will be no system sand extension required (see illustration on next page).

Illustration of Example #3 (Multi-Level™ commercial):

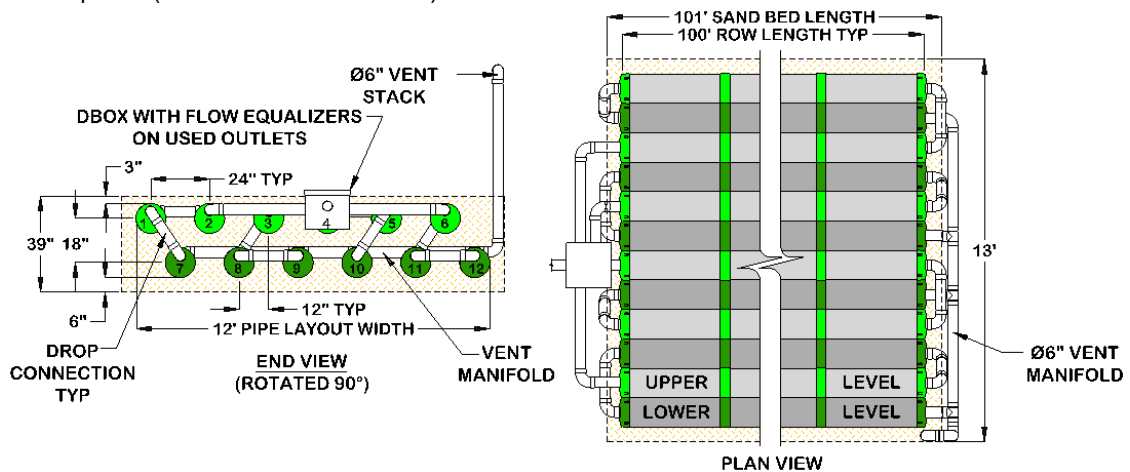

Notes:

- 1) Vent stack and manifold required to be 6 inches in diameter when venting more than 1,000 ft. of pipe. Multiple 4-inch vent systems would be an acceptable configuration but will result in at least two vent stacks.
- 2) Serial section #1 (rows 1, 2 & 7), Section #2 (rows 3, 8 & 9), Section #3 (rows 4, 5 & 10), Section #4 (rows 6, 11 & 12). Serial sections always start in the upper level before feeding the lower level.
- 3) Alternate layouts possible, for example: 3 sections (section #1: rows 1, 2, 7 & 8), (section #2: rows 3, 4, 9 & 10), (section #3: rows 5, 6, 11 & 12).

11.0 Presby Environmental Standards and Technical Support

All AES and ES Systems must be designed and installed in compliance with the procedures and specifications described in this Manual and in the product's New Hampshire approval. This Manual is to be used in conjunction with the State of New Hampshire Department of Environmental Services (DES) Administrative Rules Env-Wq 1000. In the event of contradictions between this Manual and New Hampshire DES regulations, Presby Environmental, Inc. should be contacted for technical assistance at (800) 473-5298. Exceptions to any New Hampshire rules other than those specifically discussed in this Manual require a DES waiver.

12.0 Advanced Enviro-Septic and Enviro-Septic Sizing

AES and ES use the same bed sizing tables, pipe and installation requirements noted in this manual with the exception that systems must meet the vertical separation distances shown in Table D. See Section 14.1, below for additional AES requirements.

13.0 Certification Requirements

Any designers and installers who have not previously attended a Presby Environmental, Inc. Certification Course are strongly encouraged to obtain Presby Certification. Certification is obtained by attending a Certification Course presented by Presby Environmental, Inc. or its sanctioned representative. Certification can also be obtained by viewing tutorial videos on our website (high speed connection required) and then successfully passing a short assessment test, which is also available over the internet. All professionals involved in the inspection, review or certification of Presby Systems should also become Presby Certified. Professionals involved in the design or installation of Multi-Level™ systems **must** be Presby Certified.

14.0 Design Criteria

14.1 Advanced Enviro-Septic Requirements

- a) Sewn seam must be oriented in the 12 o'clock position. This correctly orients the Bio-Accelerator fabric in the 6 o'clock position.
- b) Venting is always required regardless of vertical separation to restrictive features or daily flow for AES.
- c) Vertical separation distances per Table D (measured to the bottom of the AES pipe).
- d) For perc rates 51-60 MPI, the minimum row length is 65 ft.
- e) Regarding product substitution, AES may be substituted for ES as long as the plans and permits comply with laws and regulations. ES may not be substituted for AES. Contact NH DES with questions or concerns.

14.2 Barrier Materials over System Sand

No barrier materials (hay, straw, tarps, etc.) are to be placed between the System Sand and cover material; such materials may cut off necessary oxygen supply to the system.

14.3 Converging Flows Restriction

AES and ES Systems must not be located where surface or ground waters will converge, causing surface water flow to become concentrated or restricted within the soil absorption field.

14.4 Daily Design Flow

Residential daily design flow for AES and ES Systems is calculated in accordance with New Hampshire rules.

- a) Systems servicing more than two residences shall use the Commercial portions of all sizing Tables.
- b) The minimum daily design flow for any single-family residential system is two bedrooms (150 GPD per bedroom) and 300 GPD for any commercial system.
- c) In-Law apartments shall be calculated as two bedrooms.
- d) Certain fixtures, such as jetted tubs, may require an increase in the size of the septic tank.
- e) Daily design flow for a single bedroom apartment with a kitchen connected to a residence (also sometimes referred to as a "studio" or "in-law apartment") shall be calculated by adding two additional bedrooms (300 GPD).
- f) When daily design flow is determined by water meter use for commercial systems, refer to the NH Rules. PEI recommends taking the average daily use from a peak month and multiply it by a peaking factor of 2 to 3 times.
- g) Note that "daily design flows" are calculated to assume occasional "peak" usage and a factor of safety; Systems are not expected to receive continuous dosing at full daily design load.

14.5 End-to-End Beds Preferred Over Side-to-Side Beds

If site conditions permit, End-to-End multiple bed configurations are preferable to Side-to-Side configurations (see para. 22.0, pg. 16).

14.6 Fill Extensions for Elevated (Mound) Systems

If any portion of the bed extends above the original grade the fill covering the field cannot begin the side slope tapers for a distance of 3 ft. minimum from the outmost edge of any AES or ES pipe (see ill. in para. 35.0, pg. 29).

14.7 Filters, Alarms & Baffles

- a) Effluent Filters are not required in New Hampshire and not recommended for use with our systems
- b) If a filter is used it **must** be maintained on at least an annual basis. Follow manufacturer's instructions regarding required inspections, cleaning and maintenance of the effluent filter
- c) Effluent Filters must allow the free passage of air to ensure the proper functioning of the system. A blocked filter in any on-site septic system could interfere with venting, causing the system to convert to an anaerobic state and result in a shortened life.
- d) All pump systems to have a high-water alarm float or sensor installed inside the pump chamber
- e) All septic tanks must be equipped with baffles to prevent excess solids from entering the system
- f) Charcoal filters in vent stacks (for odor control) are not recommended by PEI. They can block air flow and potentially shorten system life. Contact PEI for recommendations to correct odor problems.

14.8 Flow Equalizers Required

All distribution boxes used to divide effluent flow require flow equalizers in outlets to the field (not vents). Flow equalizers are limited to a maximum of 20 GPD per equalizer. Basic Serial Distribution does not require flow equalizers.

14.9 Garbage Disposals (a.k.a. Garbage Grinders)

No additional AES or ES pipe is required when using a garbage disposal (grinder). If a garbage disposal is utilized, follow the NH DES requirements regarding septic tank sizing. Multiple compartment septic tanks or multiple tanks are preferred and should be pumped as needed.

14.10 Pressure Distribution

The use of pressure distribution lines in AES or ES Systems is **prohibited**. Pumps may be utilized when necessary only to gain elevation and to feed a distribution box which then distributes effluent by gravity to the field.

14.11 Row Requirements

- All beds must have at least 2 rows.
- Maximum row length for any system is 100 ft.
- Recommended minimum row length is 30 ft.
- A combination (or D-box) distribution system must be used if any row length is less than 30 ft. The D-box must feed at least 30 ft. of pipe, a minimum of two D-box outlets must be used and the field must be vented.
- Row Center-to-Center Spacing is 1.5 ft. min. for all systems. Row spacing may be increased but is not required.
- For Sloping Beds: the elevations for each AES or ES row must be provided on the drawing.
- All rows must be laid level to within $\pm 1/2$ in. (total of 1 in.) of the specified elevation and preferably should be parallel to the contour of the site.
- It is easier if row lengths are designed in exact 10 ft. increments since AES or ES pipe comes in 10 ft. sections. However, if necessary, the pipe is easily cut to any length to meet site constraints.
- Rows may be placed "in-line" along a single contour using raised straight connectors (see para.3.9, pg. 4).

Illustration of row lengths less than 30 ft:

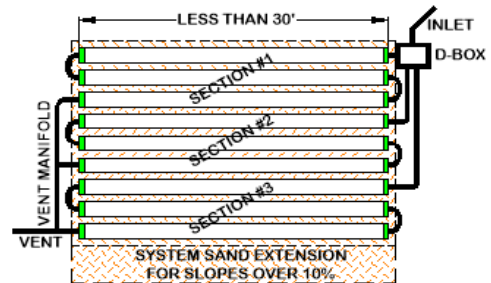

14.12 System Side Slopes (Side Slope Tapers)

Side slope tapering begins 3 ft. from the edge of the AES or ES pipe and is to be no steeper than trim 3:1, except that a slope of 2:1 may be used if necessary to maintain the side slopes on-lot or avoid an existing permanent structure (see illustration in para. 35.0, pg. 29).

14.13 Separation Distances (Horizontal and Vertical)

Separation distances to the seasonal high-water table (SHWT) or other restrictive features are measured from the outermost edge of the AES or ES pipe. Vertical separation to SHWT and/or restrictive features for all AES or ES pipe models is listed in Table D, see para. 6.0, pg. 5.

14.14 Sloping Sites and Sloping Mound Systems

- The percentage of slope in all system drawings refers to the slope of the system, not the existing terrain ("site slope") and refers to the slope of the bed itself ("system slope").
- The system slope and the site slope do not have to be the same.
- Maximum site slope is 34% and maximum system slope is 25%.

14.15 System Sand Bed Height Dimension

The height of an AES or ES Sand Bed measures 21 in. minimum (not including cover material):

- 6 in. minimum of System Sand below the AES or ES pipe; and
- 12 in. diameter of the pipe; and
- 3 in. minimum of System Sand above the AES or ES pipe.
- The System Sand Extension area is required to be a minimum of 6 in. deep (see illustration of sloping bed in para. 35.0, pg. 29).

14.16 Two Inch Rule

The outlet of a septic tank or distribution box must be set at least 2 in. above the highest inlet of the AES or ES row, with the connecting pipe slope not less than 1% (approximately 1/8 in. per foot). Illustration of 2 in. rule:

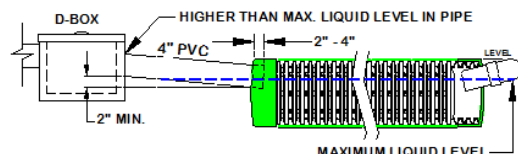

14.17 Topographic Position Requirement

The system location must be located in an area that does not concentrate water, both surface and subsurface. If allowed by state and local authorities, altering the terrain upslope of a system may alleviate this requirement if the waters are sufficiently altered to redirect flows away from the field.

14.18 Wastewater Strength

Please contact Presby Environmental for design recommendations when dealing with high strength effluent. High strength wastewater is septic tank effluent quality with combined 30-day average carbonaceous biochemical oxygen demand (CBOD) and total suspended solids (TSS) in excess of two-hundred and fifty (250) mg/L.

14.19 Water Purification Systems

- Water purification systems and water softeners should **not** discharge into any AES or ES system. This “backwash” does not require treatment and the additional flow may overload the system. NH allows for alternative means of dispersal.
- If there is no alternative means of disposing of this backwash other than into the system, then the field will need to be “oversized.” Calculate the total amount of backwash in GPD, multiply by 3, and add this amount to the daily design flow when determining the field and septic tank sizing.
- Water purification systems and water softeners require regular routine maintenance; consult and follow the manufacturer’s maintenance recommendations.

15.0 Basic Serial Distribution (Single Level)

AES or ES rows are connected in series at the ends with raised connections, using offset adapters. Basic Serial distribution systems are quick to develop a strong biomat in the first row, provide a longer flow route, improved effluent treatment and ensure air will pass through all the rows. Other criteria:

- May be used for single beds of 900 GPD or less.
- Basic Serial distribution incorporates rows in serial distribution in a single bed.
- Maximum length of any row is 100 ft.
- Flow Equalizers are not required for Basic Serial systems because they do not divide flow to the bed.
- For beds sloping over 10%, a System Sand Extension is placed entirely on the downhill side and must be at least 3 ft.

Illustrations of Basic Serial Systems (Level Bed on left and Sloping Bed on right):

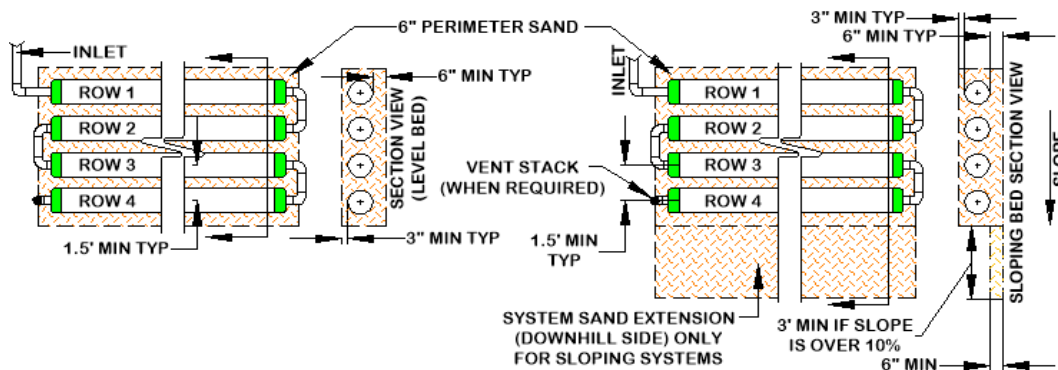

15.1 Non-Conventional Basic Serial Configuration

Bed may be constructed with unusual shapes to avoid site obstacles or meet setback requirements.

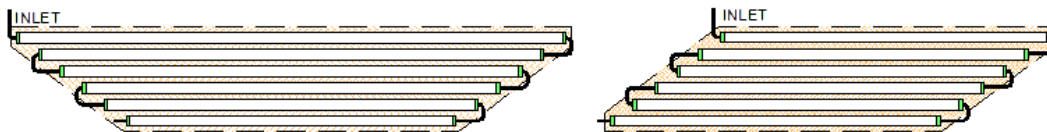

15.2 Curved Beds

AES and ES pipe is flexible enough to be contoured to site specific features; like a driveway (see illustration below).

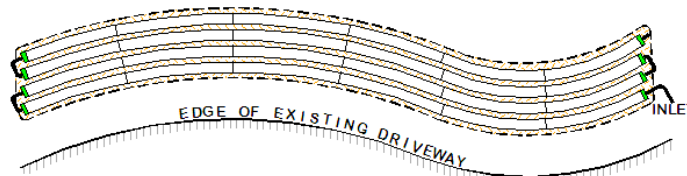

15.3 Angled and Curving Beds

Angled configurations are used to avoid obstacles.

- Rows should follow the contour of the site as much as possible
- Rows are angled by bending pipes up to 90 degrees or through the use of offset adapters
- Row lengths are required to be a minimum of 30 ft.
- Multi-Level™ systems may take advantage of angled bed configurations.
- Illustrations of Angled Beds:

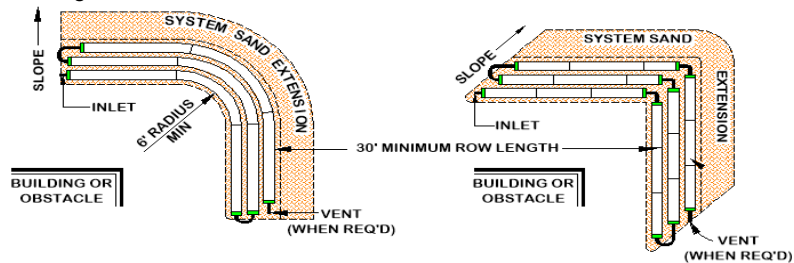

16.0 Basic Serial Distribution (Multi-Level™)

Basic Serial Multi-Level™ systems can use AES or ES pipe and must conform to the same requirements for single level basic serial systems except:

- Pipe requirements per Table F on page 6.
- Row spacing per Table G on page 6.
- All Multi-Level™ beds require venting. The vent must be connected to the last row in the series on the Lower Level.
- Multi-Level™ systems are limited to soils with a perc rate of 30 MPI or less.
- For beds sloping over 10% the System Sand Extension must be 12-in. thick
- The 3 ft. offset (fill extension) measured from the AES or ES pipe before starting the side slope tapers, is measured from the Upper Rows.
- 6 inches of System Sand minimum separates the Upper Level Rows from the Lower Level Rows.
- Effluent is delivered first to the Upper Rows, which then connects to the Lower Level Rows by way of a Drop Connection.
- The Drop Connection must pitch downward toward the Lower Level at least 2 inches.
- Multi-Level™ systems are not allowed in H-20 applications.

Illustrations of level Multi-Level™ Basic Serial System:

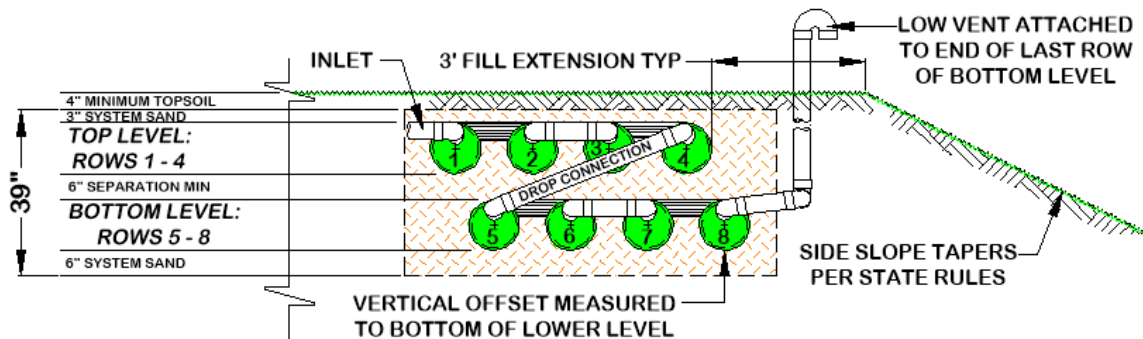
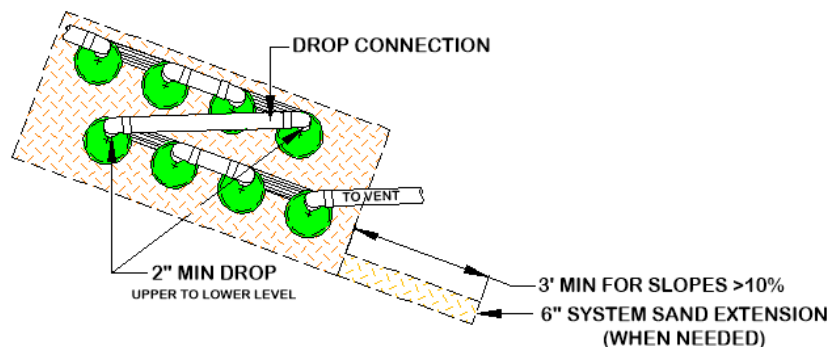
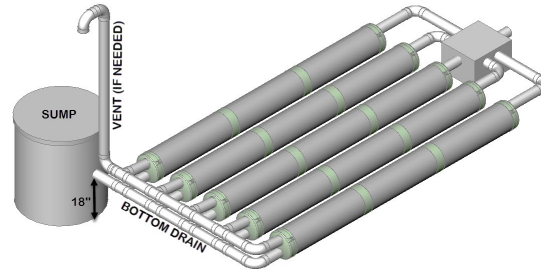

Illustration of sloping Multi-Level™ Basic Serial System:



17.0 Bottom Drain

A bottom drain is a line connected to the hole in the 6 o'clock position of a double offset adapter at the end of each serial section or each row in a D-box Distribution Configuration which drains to a sump and is utilized to lower the water level in a saturated system or to facilitate system rejuvenation. There must be 18 inches from the bottom of the sump to the bottom of the drain. The sump should be brought above the final grade and have a locking or mechanically fastened cover. The bottom drain may be placed on either end of the field. Illustration of a Bottom Drain for Parallel Distribution Layout (vent as required):



Note: the bottom drain may connect to the bottom of every row even with serial or combination layouts.

18.0 Butterfly Configuration

- A "butterfly configuration," is considered to be a single bed system with two or more sections (can also be D-box or Combination configurations).
- Maximum length of any row is 100 ft.
- Serial Section loading limit is 500 GPD.
- Beds can contain any number of serial sections.
- 3 ft. System Sand Extension is required on downhill side of beds that slope over 10%.

Illustration of a Butterfly configuration:

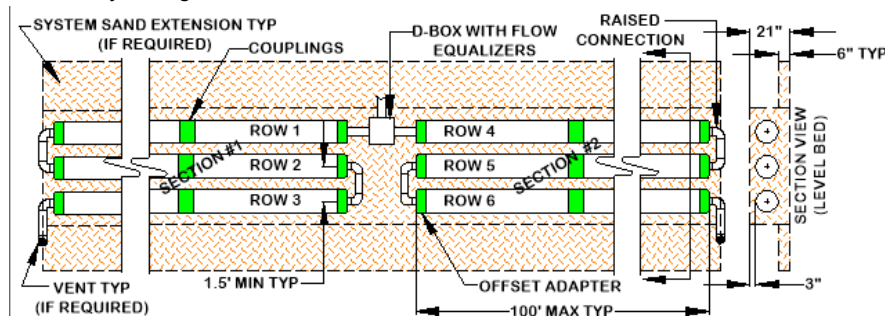

19.0 Combination Serial Distribution (Single Level)

Combination Serial distribution within one bed, or multiple beds, is required for systems with daily design flows greater than 900 GPD. Combination Serial distribution is quick to develop a strong biomat in the first row of each section, providing improved effluent treatment. Each Combination Serial section is limited to a maximum loading of 500 gallons/day.

- Combination Serial distribution consists of two or more serial sections installed in a single bed
- Each serial section in a Combination System consists of a series of AES or ES rows connected at the ends with raised connections, using offset adapters
- Maximum length of any row is 100 ft.
- Each Serial Section must contain at least: total AES or ES pipe required min. ÷ number of serial sections
- Serial Section loading limit is 500 GPD
- There is no limit on the number of Combination Serial Sections within a bed
- System Sand Extension (if required) placed entirely on downhill side of bed (as shown).
- When the vent manifold is on the same side as the serial section inlets, the manifold runs over the top of these inlets (as shown).

Illustrations of Single Level Combination Serial Systems (Level Bed on left and Sloping Bed on right):

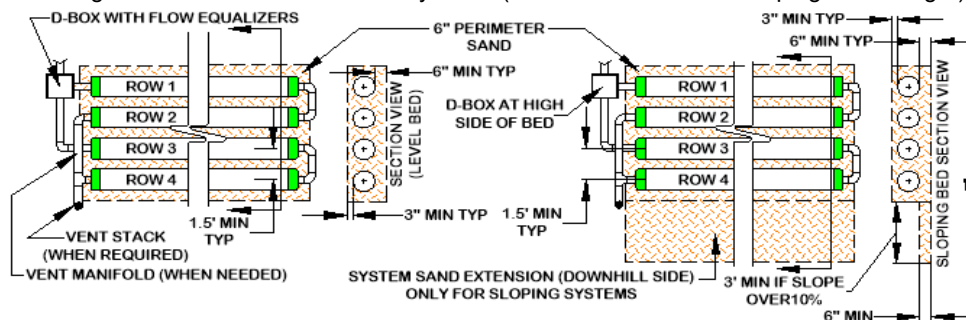

19.1 Serial Section Loading

Each serial section in a Combination Serial system has a maximum daily design flow of 500 GPD. More than the min. number of sections may be used. Ex: Daily design flow = 1,000 GPD requires $(1,000 \div 500) = 2$ sections min.

19.2 Serial Section Length Requirement

- Each serial section must have the minimum linear feet of pipe
- The minimum linear feet of pipe per serial section is determined by dividing the total linear feet required in the field by the number of sections required.
- A serial section may exceed the minimum linear feet required.
- Rows within a serial section may vary in length to accommodate site constraints.

19.3 Non-Conventional Combination Serial Configuration

Illustration of Irregular shaped combination system (venting not shown):

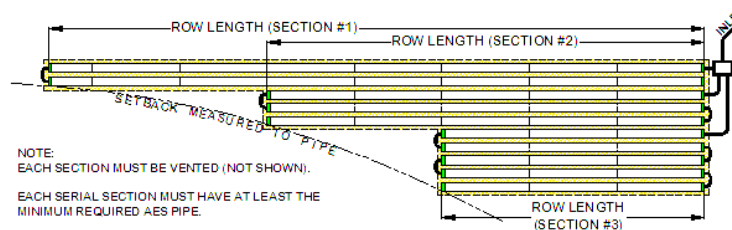

20.0 Combination Serial Distribution (Multi-Level™)

Combination Multi-Level™ systems can use AES or ES pipe and must conform to the requirements for single level combination systems except:

- Pipe requirements per Table F on page 6
- Row spacing per Table G on page 6.
- Effluent must first be delivered to the Upper Level rows from the D-box. A Drop Connection delivers effluent from the Upper Level rows to the Lower Level rows.
- All Multi-Level™ beds require venting. The ends of all serial sections on the Lower Level are manifolded and taken to a vent stack. Each serial section may be vented separately.
- Multi-Level™ systems are limited to soils with a perc rate of 30 MPI or less.
- For beds sloping over 10% the System Sand Extension must be 12 in. thick
- The 3 ft. offset (fill extension) is measured from the AES or ES pipe in the Upper Level before starting the side slope tapers.
- A minimum of 6 in. of System Sand separates the Upper Level Rows from the Lower Level Rows.
- Effluent is delivered first to the Upper Rows of each serial section, which then connects to the Lower Level Rows by way of a Drop Connection.
- The Drop Connection must pitch downward toward the Lower Level at least 2 inches.

Illustration of Level Multi-Level™ Combination Serial System:

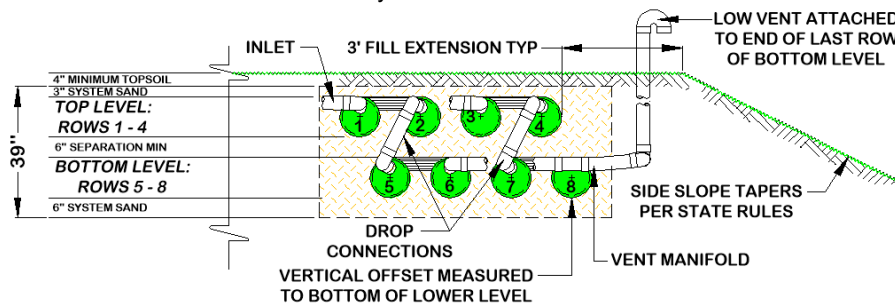
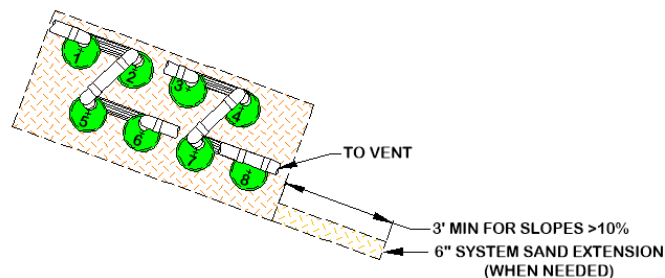

Illustration of sloping Multi-Level™ Combination serial system (2 sections shown in this example):



21.0 D-box Distribution (Single Level)

- All rows in this configuration must be the same length
- Flow equalizers must be used in the D-box outlets feeding AES or ES pipes
- Use a manifold to connect the ends of all rows to ensure adequate distribution (even when a vent is not required). The top of the manifold should be even with the top of the AES or ES pipes and sloped toward the AES or ES pipes. The manifold should be placed 2 in. to 4 in. into the Offset Adapters (same as Raised Connections).
- Maximum row length is 100 ft.
- Place the D-box on level, firmly compacted soil
- All rows must be laid level end-to-end within $\pm 1/2$ in. (1 in. total)
- A 2-inch min. drop is required between the D-box outlets and the AES or ES pipe inlets
- System Sand Extension (if required) placed entirely on downhill side of sloping beds (as shown)
- D-box systems are not allowed for use in Multi-Level™ beds

Illustrations for D-box (Parallel) Distribution:

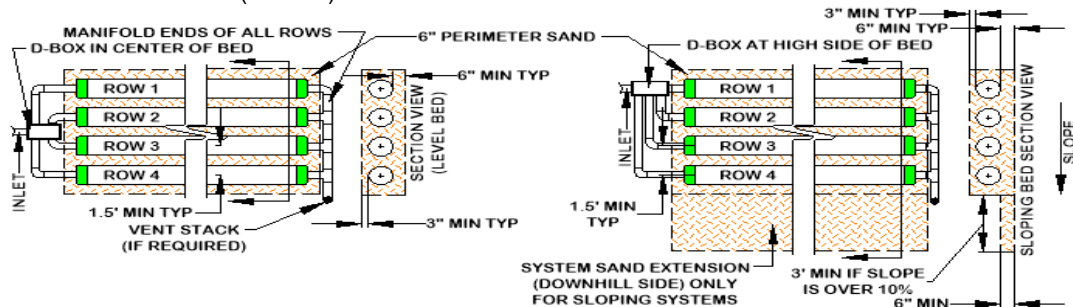

22.0 Multiple Bed Distribution

Multiple Bed distribution incorporates two or more beds (single level or Multi-Level™), each bed with Basic Serial, Combination Serial, or D-box distribution, and each receiving an equal amount of effluent from a D-box. Multiple beds may be oriented along the contour of the site or along the slope of the site.

- Each bed must have the same minimum linear feet of pipe. The minimum linear feet of pipe per bed is determined by dividing the total linear feet of pipe required in the system by the number of beds.
- Rows within a bed may vary in length to accommodate site constraints, except with D-box configuration which requires all rows to be the same length
- End-to-End configurations are preferred to Side-to-Side configurations
- In Side-to-Side configuration, one bed is placed down slope of another. Bed separation distance is measure from pipe-to-pipe
- Multi-Level™ may be used in multiple bed configurations

Illustration of End-to-End Multiple Beds:

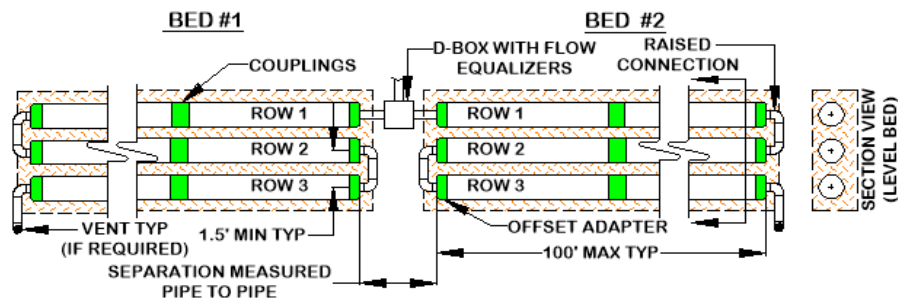
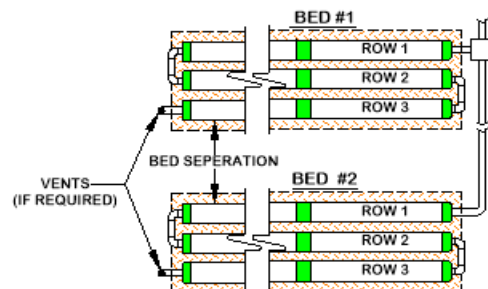

Illustration of Side-to-Side Multiple Beds:



23.0 Elevated Bed Systems (Mounds)

Elevated beds are designed for sites with soil, depth to groundwater or restrictive feature constraints that do not allow for In-Ground Bed Systems. An elevated bed system is a soil absorption field with any part of the field above original grade. Elevated bed systems require 3 ft. fill extensions on each side (measured from the pipe), after which side-slope tapering is to be a maximum of 3 horizontal feet for each 1 foot of vertical drop until it meets existing grade, except that a slope of 2:1 may be used if necessary to maintain the side slopes on-lot or avoid an existing permanent structure. See illustration of elevated beds in para. 35.0, pg. 29.

23.1 System Sand Extension

In Systems sloping more than 10%, a System Sand extension is required. The System Sand extension area is additional System Sand added to the down slope side of all systems sloping more than 10%. The System Sand extension area is a minimum of 6 inches deep and extends a minimum of 3 ft. beyond the tall portion of the System Sand bed on the down slope edge of the bed. For multiple slope beds, if any portion of the bed has a system slope greater than 10% a system sand extension is required.

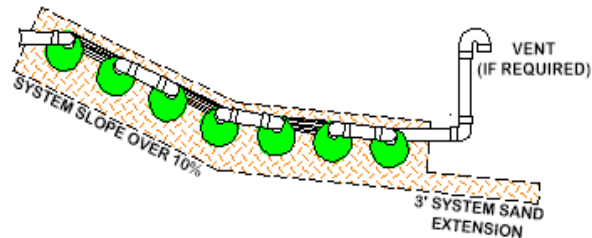

Illustration of bed with multiple slopes to right:

23.2 Total Linear Feet Requirement

- Maximum row length is 100 ft.
- Each section or bed must have at least the minimum linear feet of pipe (total feet of pipe required divided by number of sections equals the minimum number of feet required for each section or bed).
- A section or bed may exceed the minimum linear length.
- Rows within a section or bed may vary in length (except D-box configurations) to accommodate site constraints.

24.0 In-Ground Bed Systems

AES or ES systems are installed below existing grade for sites with no soil restrictive features to limit placement. In-Ground systems that slope over 10% require a 3 ft. system sand extension on the downhill side of the field.

Illustration of in-ground on level site:

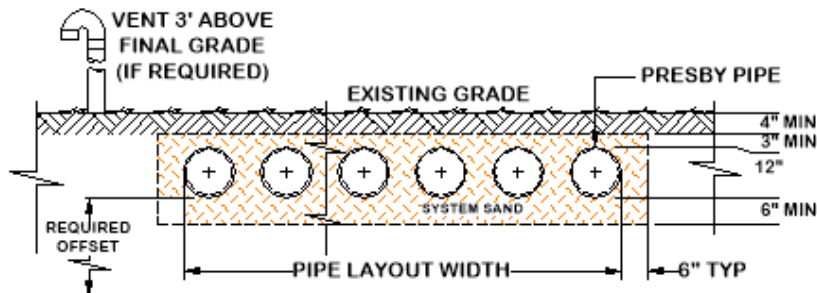

25.0 Non-Conventional System Configurations

Non-conventional system configurations may have irregular shapes to accommodate site constraints. A site-specific waiver from the state may be required for non-conventional configurations.

26.0 H-20 Wheel Loading

If a system is to be installed below an area that will be subjected to vehicular traffic, it must be designed and constructed as depicted below in order to protect the system from compaction and/or damage. Note that a layer of stabilization fabric is added between the System Sand and the cover material. Proper soil compaction (no voids around the pipes) during construction is critical to a successful H-20 installation. "Walking-the-rows" is important to removing sand voids around the pipes as the System Sand is placed around the pipes. Do not use vibratory compactors when placing System Sand. Cover material should only be compacted at the point of preparation for pavement. All H-20 systems require venting.

Illustration of H-20 system on next page.

Illustration of H-20 system:

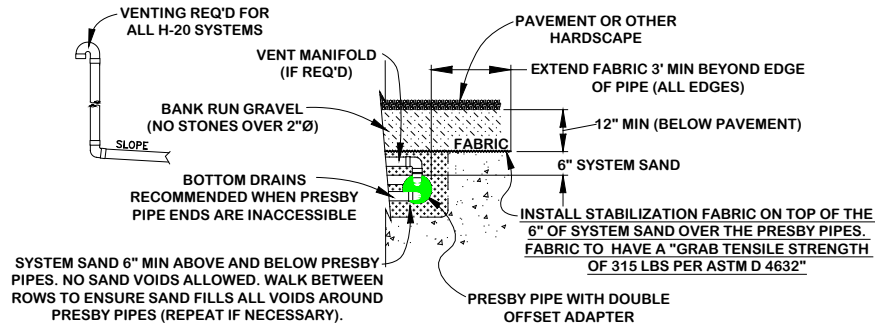

27.0 Pumped System Requirements

Pumped systems supply effluent to the field by using a pump and distribution box when site conditions do not allow for a gravity system.

27.1 Alarm

NH rules require all pump systems to have a high-water alarm float or sensor installed inside the pump chamber.

27.2 Differential Venting

All pump systems must use differential venting (see illustration, para. 29.4, pg. 20).

27.3 Distribution Box

All pump systems require a distribution box (see para. 3.5, pg. 3) with some means of velocity reduction for the effluent entering the D-box (see para. 3.7, pg. 4 to see manifolded distribution box used to divide flows evenly).

27.4 Velocity Reduction

The rate at which effluent enters the AES or ES pipe must be controlled. Excessive effluent velocity can disrupt solids that settle in the pipes.

- Effluent must never be pumped directly into the AES or ES pipe.
- A distribution box or tank must be installed between the pumping chamber and the AES or ES pipe to reduce effluent velocity.
- Force mains must discharge into a distribution box (or equivalent) with velocity reducer and/or a baffle, 90° bend, tee or equivalent (see illustrations below).

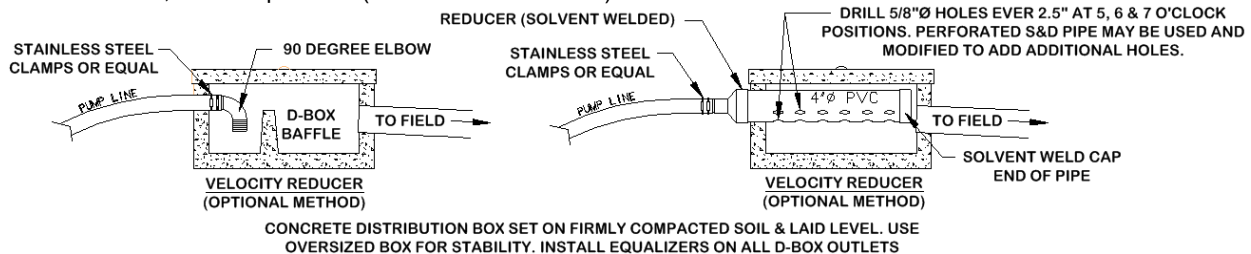

27.5 Dose Volume

- Pump volume per dose must be no greater than 1-gallon times the total linear feet of AES or ES pipe.
- Pump dosing should be designed for a minimum of 6 cycles per daily design flow.
- If possible, the dosing cycle should provide one hour of drying time between doses.

27.6 Basic Serial Distribution Limit

Pumped systems with Basic Serial distribution are limited to a maximum dose rate of 40 gallons per minute and do not require the use of a flow equalizer on the D-box outlet. Never pump directly into AES or ES pipe.

27.7 Combination and Multiple-Bed Distribution Limit

All AES or ES systems with Combination Serial distribution or Multiple Bed distribution must use Flow Equalizers in each distribution box outlet. Each Bed or serial section of Combination system is limited to a maximum of 20 gallons per minute, due to the flow constraints of the equalizer. Example: pumping to a combination system with 3 sections (using three D-box outlets). The maximum delivery rate is $(3 \times 20) = 60$ GPM. Always provide a means of velocity reduction.

28.0 System Sand and Sand Fill Requirements for All Beds

It is critical to the proper functioning of field that the proper amount and type of System Sand be installed (see para. 3.11 on pg. 4 for definitions of System Sand).

28.1 Quantity of System Sand

System Sand is placed a minimum of 6 in. below and between the pipe rows, a minimum of 3 in. over the pipes and a minimum of 6 in. of System Sand is placed horizontally around the perimeter of all pipe rows. When constructing for H-20 loading, place at least 6 in. of System Sand over all pipes before adding additional fill (see para. 26.0 on pg. 17 for complete H-20 details).

28.2 Sand Fill

Sand fill is used to raise the elevation of the system in order to meet the required separation distance from the SHWT or other restrictive feature and also in the fill extensions. Sand fill is defined by NH Env-Wq 1021.03. No organic material is allowed. System Sand may be used in place of sand fill; however, this may increase material costs.

29.0 Venting Requirements

An adequate air supply is essential to the proper functioning of Presby Systems. Venting is required for:

- a) All systems using AES pipe
- b) All H-20 wheel load applications (when the field will be subjected to vehicular traffic)
- c) More than 18-inches of material cover (including System Sand) on top of the AES or ES pipes
- d) The bed is covered with an impermeable soil or an impermeable barrier
- e) All Multi-Level™ beds

29.1 General Rules

- a) Vent openings must be located to ensure the unobstructed flow of air through the entire system. Do not install charcoal filters in vent openings.
- b) The low vent inlet must be a minimum of 3 ft. above final grade or anticipated snow level
- c) One 4-inch vent is required for every 1,000 ft. of AES or ES pipe.
- d) A single 6-inch vent may be installed in place of up to three 4 in. vents.
- e) If a vent manifold is used, it must be at least the same diameter as the vent(s).
- f) When venting multiple beds, it is preferred that each bed be vented separately rather than manifolding bed vents together.
- g) Remote or By-Pass venting may be utilized to minimize the visibility of vent stacks.

29.2 Differential Venting

- a) Differential venting is the use of high and low vents in a system (see illustration below).
- b) In a gravity system, the roof stack acts as the high vent.
- c) High and low vent openings must be separated by a minimum of 10 vertical feet.
- d) If possible, the high and low vents should be of the same capacity.
- e) Sch. 40 PVC or equivalent should be used for all vent stacks.
- f) Anchor the High vent to a post or another stable object.

Illustration of Differential Venting to right:

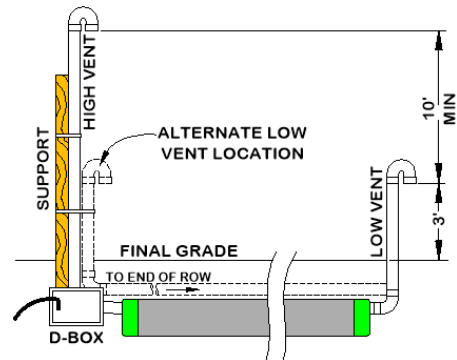

29.3 Vent Locations for Gravity Systems

- a) A low vent through an offset adapter is installed at the end of the last row of each serial section or the end of the last row in a Basic Serial bed, or at the end of each row in a D-box Distribution Configuration system. A vent manifold may be used to connect the ends of multiple sections or rows.
- b) The house (roof) vent functions as the high vent as long as there are no restrictions or other vents between the low vent and the house (roof) vent
- c) When the house (roof) vent functions as the high vent, there must be a minimum of a 10 ft. vertical differential between the low and high (roof) vent openings

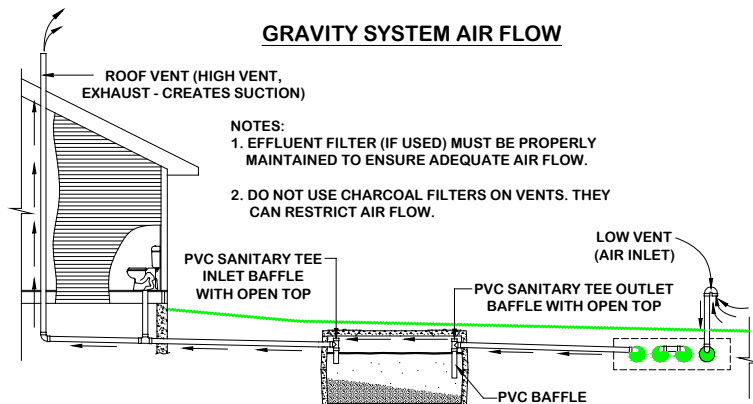

29.4 Pump System Vent Locations

- A low vent is installed through an offset adapter at the end of each section, Basic Serial bed or attached to a vent manifold.
- A high vent is installed through an unused distribution box outlet.
- A 10 ft. minimum vertical differential is required between high and low vent openings.
- When venting multiple beds, it is preferred that each bed be vented separately (have their own high and low vents) rather than manifolding bed vents together.
- The low vent may be attached to the D-box and the high vent attached to the end of the last row (or manifold) only when the D-box is insulated against freezing.
- See illustration para. 29.2, pg. 19.

29.5 Vent Manifolds

A vent manifold may be incorporated to connect the ends of a number of sections or rows of pipe to a single vent opening. See illustrations below.

Combination System:

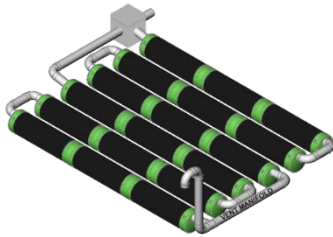

Parallel D-box System:



Manifold on Distribution Box Side:

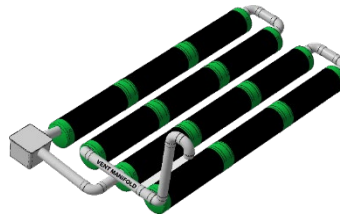

29.6 Vent Piping Slope

Vent piping should slope downward toward the system to prevent moisture from collecting in the pipe and blocking the passage of air.

29.7 Remote Venting

If site conditions do not allow the vent pipe to slope toward the system, or the owner chooses to utilize remote venting for aesthetic reasons (causing the vent pipe not to slope toward the system), the low point of the vent line must be drilled creating several 1/4 in. holes to allow drainage of condensation. This procedure may only be used if the vent pipe connecting to the system has:

- A **high point** that is above the highest point of all AES or ES pipes or the Distribution Box; and,
- A **low point** opened for drainage which is above the SHWT. (See diagram below.)

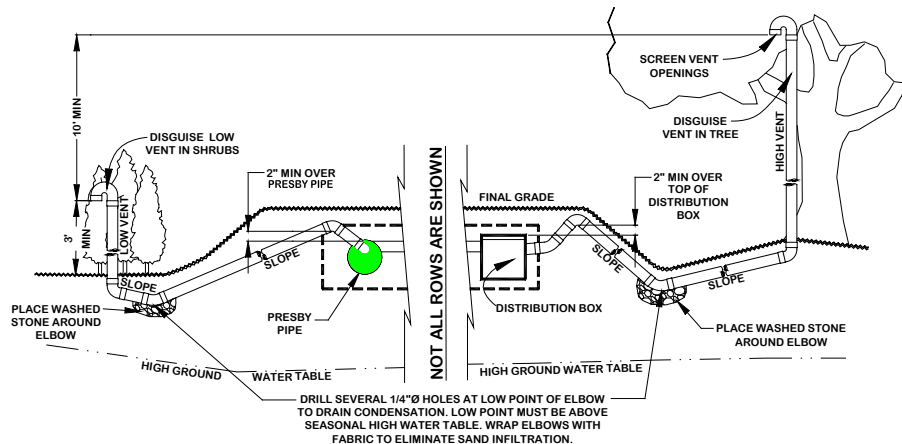

29.8 By-Pass Venting

By-Pass Venting directly connects the distribution box to the pump chamber or septic tank as shown below. There must be at least 10 ft. of change in elevation between the openings of the roof stack and low vent.

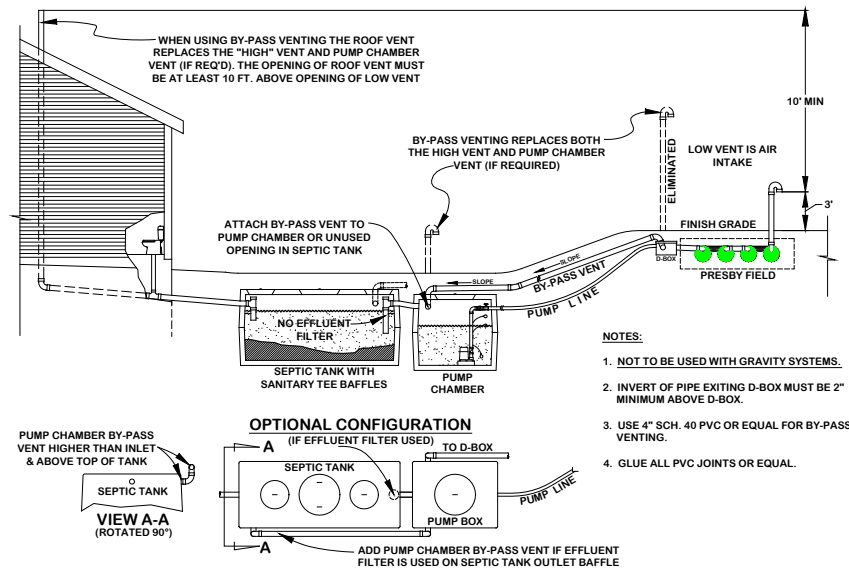

30.0 Site Selection

30.1 Determining Site Suitability

Refer to New Hampshire Rules regarding site suitability requirements.

30.2 Topography

Locate systems on convex, hill, slope or level locations that do not concentrate surface flows. Avoid swales, low areas, or toe-of-slope areas that may not provide sufficient drainage away from the system.

30.3 Surface Water Diversions

Surface water runoff must be diverted away from the system. Diversions must be provided up-slope of the system and designed to avoid ponding. Systems must not be located in areas where surface or groundwater flows are concentrated.

30.4 Containment

Systems should not be located where structures such as curbs, walls or foundations might adversely restrict the soil's ability to transport water away from the system.

30.5 Hydraulic loading

Systems should not be located where lawn irrigation, roof drains, or natural flows increase water loading to the soils around the system.

30.6 Access

Systems should be located to allow access for septic tank maintenance and to at least one end of all pipe rows. Planning for future access will facilitate Rejuvenation in the unlikely event the system malfunctions.

30.7 Rocky or Wooded Areas

Avoid locating systems in rocky or wooded areas that require additional site work, since this may alter the soil's ability to accept water. No trees or shrubs should be located within 10 ft. of the system to prevent root infiltration.

30.8 Replacement System

In the unlikely event that a system needs to be replaced, design and installation must comply with state laws and regulations (contact NH DES with questions or concerns). Additional considerations include:

- a) The new system can be installed in the same location.
- b) All unsuitable material must be removed prior to replacement system construction.
- c) Disposal of hazardous materials to be in accordance with state and local requirements.
- d) Contact PEI for guidance on options for replacement system designs.

31.0 Installation Requirements, Component Handling and Site Preparation

31.1 Component Handling

- a) Keep mud, grease, oil, etc. away from all components.
- b) Avoid dragging pipe through wet or muddy areas.
- c) Store pipe on high and dry areas to prevent surface water and soil from entering the pipes or contaminating the fabric prior to installation.
- d) The outer fabric of the AES and ES pipe is ultra-violet stabilized; however, this protection breaks down after a period of time in direct sunlight. To prevent damage to the fabric, cover the pipe with an opaque tarp if stored outdoors.

31.2 Critical Reminder Prevent Soil Compaction

It is critical to keep excavators, backhoes, and other equipment off the excavated or tilled surface of a bed. Before installing the System Sand, excavation equipment should be operated around the bed perimeter; not on the bed itself.

31.3 Site Preparation Prior to Excavation

- a) Locate and stake out the System Sand Bed, extension areas and soil material cover extensions on the site according to the approved plan.
- b) Install sediment/erosion control barriers prior to beginning excavation to protect the system from surface water flows during construction.
- c) Do not travel across or locate excavation equipment within the portion of the site receiving System Sand.
- d) Do not stockpile materials or equipment within the portion of the site receiving System Sand.
- e) It is especially important to avoid using construction equipment down slope of the system to prevent soil compaction.

31.4 When to Excavate

- a) Do not work wet or frozen soils. If a fragment of soil from about 9 in. below the surface can easily be rolled into a wire, the soil moisture content is too high for construction.
- b) Do not excavate the system area immediately after, during or before precipitation.

31.5 Tree Stumps

Remove all tree stumps and the central root system below grade by using a backhoe or excavator with a mechanical "thumb" or similar extrication equipment, lifting or leveraging stump in a manner that minimizes soil disturbance.

- a) Do not locate equipment within the limits of the System Sand Bed.
- b) Avoid soil disturbance, relocation, or compaction.
- c) Avoid mechanical leveling or tamping of dislodged soil.
- d) Fill all voids created by stump or root removal with System Sand.

31.6 Organic Material Removal

Before tilling/scarifying, remove all grass, leaves, sticks, brush and other organic matter or debris including all topsoil from any area to receive system sand or sand fill. It is not necessary for the soil of the system site to be smooth when the site is prepared.

31.7 Raking and Tilling Procedures

All areas receiving System Sand, sand fill and fill extensions **must** be raked or tilled. If a backhoe/excavator is used to till the site, fit it with chisel teeth and till the site. The backhoe/excavator must remain outside of the proposed System Sand area and extensions.

- a) For in-ground bed systems, excavate the system bed as necessary below original grade. Using an excavator or backhoe, tilt the bucket teeth perpendicular to the bed and use the teeth to rake furrows 2 in. – 6 in. deep into the bottom of the entire area receiving System Sand or sand fill ("receiving area").
- b) For elevated bed systems remove the "A" horizon, then use an excavator or backhoe to rake furrows 2 in. – 6 in. deep into the receiving area.

31.8 Install System Sand and/or Sand Fill Immediately After Excavation

- a) To protect the tilled area (System Sand Bed Area and System Sand Extension Area) from damage by precipitation, System Sand should be installed immediately after tilling.
- b) Work off either end or the uphill side of the system to avoid compacting soil.
- c) Keep at least 6 in. of sand between the vehicle tracks and the tilled soil of the site if equipment must work on receiving soil.
- d) Track construction equipment should not travel over the installed system area until at least 12 in. of cover material is placed over the pipes.
- e) Heavy equipment with tires must never enter the receiving area due to likely wheel compaction of underlying soil structures.

31.9 Distribution Box Installation

To prevent movement, be sure D-boxes are placed level on compacted soil, sand, pea gravel base, or concrete pad.

31.10 Level Row Tolerances

Use a laser level or transit to install rows level. Variations beyond 1 in. ($\pm 1/2"$) may affect system performance and are not acceptable.

31.11 Correct Alignment of Advanced Enviro-Septic Bio-Accelerator Fabric

The Bio-Accelerator white geo-textile fabric is to be positioned centered along the bottom of the pipe rows.

31.12 Row Spacers

System Sand may be used to keep pipe in place while covering, but simple tools may also be constructed for this purpose. Two examples are shown. One is made from rebar, the other from wood. Center-to-center row spacing may be larger than specified by this manual.

Caution: Remove all tools used as row spacers before final covering.

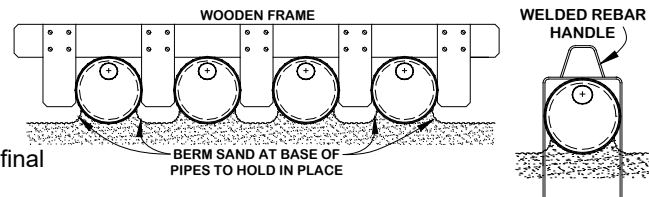

31.13 Connect Rows Using Raised Connections

Raised connections consist of offset adapters, 4 in. PVC sewer and drainpipe, and 90° elbows. They enable greater liquid storage capacity and increase the bacterial surfaces being developed. Use raised connections to connect the rows of the field (see para. 3.8, pg. 4). Glue or mechanically fasten all pipe connections.

31.14 Backfilling Rows

- Spread System Sand between the rows.
- If using AES, confirm pipe rows are positioned with Bio-Accelerator along the bottom (sewn seam up).
- Straddle each row of pipe and walk heel-to-toe its entire length, ensuring that System Sand fills all void spaces beneath the pipe.
- Finish spreading System Sand to the top of the rows and leave them exposed for inspection purposes.

31.15 Backfilling and Final Grading

Spread System Sand to a minimum of 3 in. over the pipe and a minimum of 6-in. beyond the perimeter of all pipes on all four sides of the field. Spread soil material free of organics, stones over 4-in. and building debris, having a texture similar to the soil at the site, without causing compaction. Construction equipment should not travel over the installed system area until at least 12-in. of cover material is placed over the pipes (H-10 Loading). 18-in. of cover material over the field is required for H-20 loading (see para. 26.0, pg.17).

31.16 Fill Extensions Requirements

All fields with any portion of the System Sand bed above original grade require 3-ft. fill extensions on each side beyond the outside edge of all AES or ES pipes and then tapering to meet existing grade at a maximum slope of 3:1, except that a slope of 2:1 may be used if necessary to maintain the side slopes on-lot or avoid an existing permanent structure (see illustration in para. 35.0, pg. 29).

31.17 System Soil Cover Material

A minimum of 4-in. of suitable earth cover (topsoil or loam), with a texture similar to the soil at the site and capable of sustaining plant growth, must be placed above the installed system.

31.18 Erosion Control

To prevent erosion, soil cover above the system shall be planted with native, shallow-rooted vegetation such as grass, wildflowers and certain perennials or ground covers.

31.19 Trees and Shrubs

No trees or shrubs should be located within 10-ft. of the system perimeter to prevent roots from growing into and damaging the system.

32.0 System Bacteria Rejuvenation

This section covers procedures for bacteria rejuvenation.

Note: Presby Environmental, Inc. must be contacted for technical assistance prior to attempting rejuvenation procedures.

32.1 Why would System Bacteria Rejuvenation be Needed?

Bacteria rejuvenation is the return of bacteria to an aerobic state. Flooding, improper venting, alteration or improper depth of soil material cover, use of incorrect sand, sudden use changes, introduction of chemicals or medicines, and a variety of other conditions can contribute to converting bacteria in any system from an aerobic to an anaerobic

state. This conversion severely limits the bacteria's ability to effectively treat effluent, as well as limiting liquids from passing through. A unique feature of the AES or ES System is its ability to be rejuvenated in place.

32.2 How to Rejuvenate Advanced Enviro-Septic and Enviro-Septic Bacteria

System bacteria are "rejuvenated" when they return to an aerobic state. By using the following procedure, this can be accomplished in most AES and ES Systems without costly removal and replacement.

- 1) Contact Presby Environmental before attempting Rejuvenation for technical assistance. Please note that state and/or local permits may be required.
- 2) Determine the problem causing the bacterial conversion.
- 3) Drain the tank and field of wastewater using a state approved septage hauler. This may need to be done in conjunction with step 4 to gain access to the wastewater in the field. No effluent is allowed to reach ground or surface waters.
- 4) Using a licensed installer, excavate a ditch at the far end of all the rows; remove the offset adapters; expose and open the distribution box (if present). Note: No portion of the rejuvenation ditch can ever be closer than 24 in. to the seasonal high-water table.
- 5) If foreign matter has entered the system, flush the pipes.
- 6) Safeguard all open excavations.
- 7) Guarantee a passage of air through the system.
- 8) Allow all rows to dry for 72 hours minimum. The System Sand should return to its natural color.
- 9) Re-assemble the system to its original design configuration. As long as there is no physical damage to the Presby components, the original components may be reused.

32.3 Reusable Components

AES and ES pipe or its components are not biodegradable and may be reused. In cases of improper installation, it may be possible to excavate, clean, and reinstall all system components.

33.0 Operation & Maintenance

33.1 Proper Use

Presby Systems require minimal maintenance, provided the system is not subjected to abuse. An awareness of proper use and routine maintenance will guarantee system longevity. We encourage all system owners and service providers to obtain and review a copy of our Owner's Manual, available from our website www.PresbyEnvironmental.com or via mail upon request to (800) 473-5298 or info@presbyeco.com.

33.2 System Abuse Conditions

The following conditions constitute system abuse:

- a) Liquid in high volume (excessive number of occupants and use of water in a short period of time, leaking fixtures, whirlpool tubs, hot tubs, water softening equipment or additional water discharging fixtures if not specified in system design).
- b) Solids in high volume (excessive number of occupants, paper products, personal hygiene products, garbage disposals or water softening equipment if not specified in system design)
- c) Antibiotic medicines in high concentrations
- d) Cleaning products in high concentrations
- e) Fertilizers or other caustic chemicals in any amount
- f) Petroleum products in any amount
- g) Latex and oil paints
- h) System suffocation (compacted soils, barrier materials, etc.) without proper venting

33.3 System Maintenance/Pumping of the Septic Tank

- a) Inspect the septic tank at least once every two years under normal usage.
- b) Pump the tank when surface scum and bottom sludge occupy 1/4th or more of the liquid depth of the tank.
- c) If a garbage disposal is used, the septic tank will likely require more frequent pumping.
- d) After pumping, inspect the septic tank for integrity to ensure that no groundwater is entering it. Also check the integrity of the tank inlet and outlet baffles and repair if needed.
- e) Inspect the system to ensure that vents are in place and free of obstructions.
- f) Effluent filters require ongoing maintenance due to their tendency to clog and cut off oxygen to the System. Follow filter manufacturer's maintenance instructions and inspect filters frequently.
- g) PEI and most regulatory agencies do not recommend the use of septic system additives.

33.4 Site Maintenance

It is important that the system site remain free of shrubs, trees, and other woody vegetation to within a minimum of 10 ft. of the system, including the entire System Sand bed area, and areas impacted by side slope tapering and perimeter drains (if used). Roots can infiltrate and cause damage or clogging of system components. If a perimeter drain is used, it is important to make sure that the outfall pipes are screened to prevent animal activity. Also check outfall pipes regularly to ensure that they are not obstructed in any way.

34.0 Glossary

This Manual contains terminology which is common to the industry and terms that are unique to Presby Systems. While alternative definitions may exist, this section defines how these terms are used in this Manual.

34.1 Advanced Enviro-Septic (AES) Pipe

A single unit comprised of corrugated plastic pipe, Bio-Accelerator fabric along its bottom which is surrounded by a layer of randomized plastic fibers and a sewn geo-textile fabric, is 10 ft. in length, with an outside diameter of 12 in. and a storage capacity of approximately 58 gallons. Each foot of Advanced Enviro-Septic provides over 30 sq. ft of total surface area for bacterial activity. The sewn seam is always oriented up (12 o'clock position) within the bed. A white tag is sewn into the seam indicating the product is Advanced Enviro-Septic pipe. Pipes are joined together with couplings to form rows. Advanced Enviro-Septic is a combined wastewater treatment and dispersal system.

34.2 Bio-Accelerator

Bio-Accelerator fabric screens additional solids from the effluent, enhances and accelerates treatment, facilitates quick start-up after periods of non-use, provides additional surface area for bacterial growth, promotes even distribution, and further protects outer layers and the receiving surfaces so they remain permeable. Bio-Accelerator is only available with Advanced Enviro-Septic.

34.3 Enviro-Septic (ES) Pipe

A single unit comprised of corrugated plastic pipe which is surrounded by a layer of randomized plastic fibers and a sewn geo-textile fabric, is 10 ft. in length, with an outside diameter of 12 in. and a storage capacity of approximately 58 gallons. Each foot of Enviro-Septic provides over 25 sq. ft. of total surface area for bacterial activity. A white tag is sewn into the seam indicating the product is Enviro-Septic pipe. Pipes are joined together with couplings to form the rows. Enviro-Septic is a combined wastewater treatment and dispersal system.

34.4 Drop Connection (Multi-Level™ Systems)

A drop connection is a PVC Sewer & Drainpipe configuration which is used to connect upper level rows to lower level rows in a Multi-Level™ bed. Drop connections extend 2 in. to 4 in. into the pipe and are installed with at least 2 in. of drop from the upper level row to the lower level row (see illustration in para. 16.0, pg. 13). All PVC joints should be glued or mechanically fastened.

34.5 Basic Serial Distribution

Basic Serial distribution incorporates pipe rows in serial distribution in a single bed (see Basic Serial Distribution in para. 15.0, pg. 12).

34.6 Bottom Drain

A bottom drain is a line connected to the hole in the 6 o'clock position of a double offset adapter at the end of each serial section or each row in a D-box Distribution Configuration which drains to a sump and is utilized to lower the water level in a saturated system or to facilitate system rejuvenation (see illustration in para. 17.0, pg. 14).

34.7 Butterfly Configuration

A variation of a standard, single bed system with the D-box located in the center, with rows oriented symmetrically on either side, and with each side or section receiving an equal volume of flow from the D-box (see Butterfly Configuration, para. 18.0, pg. 14).

34.8 Center-to-Center Row Spacing

Row spacing is the distance from the center of one pipe row to the center of the adjacent row.

34.9 Coarse Randomized Fiber

A mat of coarse, randomly-oriented fibers which separates more suspended solids from the effluent protecting the bacterial surface in the geo-textile fabric (see illustration in para. 2.0, pg. 2).

34.10 Combination Serial Distribution

Incorporates two or more sections of pipe in a single bed, with each section receiving a maximum of 750 GPD of effluent from a distribution box. Combination Distribution is not required for daily flows of 900 GPD or less (see Combination Serial Distribution, para. 19.0, pg. 14).

34.11 Cooling Ridges

Pipe ridges that allow the effluent to flow uninterrupted around the circumference of the pipe and aid in cooling (see illustration in para. 2.0, pg. 2).

34.12 Coupling

A plastic fitting that joins two pipe pieces in order to form rows (see para.3.4, pg. 3).

34.13 Daily Design Flow

The peak daily flow of wastewater to a system, expressed in gallons per day (GPD); systems are typically sized based on the daily design flow. Design flow calculations are set forth in the New Hampshire Rules. In general, actual daily use is expected to be one-half to two-thirds less than “daily design flow.”

34.14 Differential Venting

A method of venting a system utilizing high and low vents (see para. 29.2, pg. 19).

34.15 Distribution Box or “D-box”

A device designed to divide and distribute effluent from the septic tank equally to each of the outlet pipes that carry effluent into the system. D-boxes are also used for velocity reduction, see Velocity Reduction, para. 27.4, pg. 18.

34.16 D-box Distribution Configuration

A design in which each pipe row receives effluent from a distribution box outlet. Such a system is also called a “parallel system” or a “finger system.” See D-box (Parallel) Distribution, para. 21.0, pg. 16.

34.17 Distribution Box Manifold

A PVC configuration which connects several distribution box outlets together in order to equalize effluent flow. Refer to drawing in para. 3.7, pg. 4.

34.18 End-to-End Configuration

Consists of two or more beds constructed in a line (i.e., aligned along the width of the beds). See para.22.0, pg. 16.

34.19 Fill Extension

Utilized in constructing Elevated (mound) Systems and blend the raised portion of the system with side slope tapering to meet existing grade. Fill extensions of 3 ft. are required on all sides elevated systems and is measured from the edge of the AES or ES pipe (see para. 14.6, pg. 10).

34.20 Flow Equalizer

An adjustable plastic insert installed in the outlet pipes of a D-box to equalize effluent distribution to each outlet,

34.21 GPD and GPM

An acronym for Gallons Per Day and Gallons Per Minute respectively.

34.22 High and Low Vents

Pipes used in differential venting. Detailed information about venting requirements can be found in Venting Requirements, para. 29.0, pg. 19.

34.23 High Strength Effluent

High strength wastewater is septic tank effluent quality with combined 30-day average carbonaceous biochemical oxygen demand (CBOD) and total suspended solids (TSS) in excess of two-hundred and fifty (250) mg/L.

34.24 MPI

An acronym for Minutes Per Inch and is the numerical value by which percolation rates (also called “perc rates”) are expressed.

34.25 Multi-Level™

A Multi-Level™ System is a patented process using AES or ES pipe; it consists of two layers (Levels) of pipe installed in the same bed with one Level offset and on top of another with 6 in. of System Sand between the two Levels. Multi-Level™ Systems are approved for use in all soils with percolation rates of 60 MPI or less (see illustrations in section 16.0 page 13).

34.26 Multiple Bed Distribution

Incorporates two or more beds, each bed with Basic Serial, Combination Serial, or D-box distribution and receiving effluent from a distribution box (see para. 22.0, pg. 16).

34.27 Non-Conventional Configurations

Have irregular shapes or row lengths shorter than 30 ft. to accommodate site constraints (see para.15.1, pg. 12).

34.28 Offset Adapter

A plastic fitting with a 4 in. hole installed at the 12 o'clock position which allows for connections from one row to another and for installation of venting (see para. 3.2, pg. 3).

34.29 Percolation Rate

Also known as Perc Rate, is a numerical indication of a soil's hydraulic capacity, expressed in minutes per inch (MPI.)

34.30 Pressure Distribution

A pressurized, small-diameter pipe system used to deliver effluent to an absorption field. Pressure Distribution is not permitted to be used with the AES or ES System as these systems are designed to promote even distribution without the need for pressure distribution.

34.31 Pump Systems

Utilize a pump to gain elevation in order to deliver effluent to a D-box (see para. 27.0, pg. 18).

34.32 Raised Connection

A U-shaped, 4" diameter, PVC pipe configuration which is used to connect rows oriented in a serial configuration and to maintain the proper liquid level inside each row. See drawing in para. 3.8, pg. 4.

34.33 Raised Straight Connection

PVC pipe configuration which is used to connect pipe rows that are placed end to end along the same contour. Raised straight connections extend 2 in.- 4 in. into pipe and are installed on an angle (see drawing, para. 3.9, pg. 4).

34.34 Raking and Tilling

Refers to methods of preparing the native soil that will be covered with System Sand or Sand Fill, creating a transitional layer between the sand and the soil (see Installation Requirements, para. 31.7, pg. 22).

34.35 Row

Consists of a number of pipe sections connected by couplings with an Offset Adapter on the inlet end and an Offset Adapter on the opposite end. Rows are typically between 30 ft. and 100 ft. long.

34.36 Sand Fill

Clean sand, free of organic materials and meeting the specifications set forth in System Sand and Fill Material Specifications, para. 28.2, pg. 19. Sand fill is used to raise the elevation of the system to meet required separation distance or for use in side slope tapers. System Sand may be used in place of Sand Fill.

34.37 Section / Serial Section

A group of interconnected rows receiving effluent from one distribution box outlet. Sections are limited to 500 GPD daily design flow maximum.

34.38 Serial Distribution

Two or more pipe rows connected by a Raised Connection. Basic Serial distribution is described in detail in para. 15.0 & 16.0 on pages 12 & 13, Combination Serial distribution is described in detail in para. 19.0 & 20.0 on pages 14 & 15.

34.39 SHWT

An acronym for Seasonal High-Water Table.

34.40 Skimmer Tabs

Projections into the AES or ES pipe that help to capture grease and suspended solids from the existing effluent (see illustration in para. 2.0, pg. 2).

34.41 Side-to-Side Configuration

Consist of two or more beds arranged so that the rows are parallel to one another (see para. 22.0, pg. 16).

34.42 Slope (3:1)

In this Manual's illustrations, slope is expressed as a ratio of run to rise. Example: A slope with a grade of (3:1) is the difference in horizontal distance of three (3) horizontal feet (run) over an elevation difference of one (1) ft. (rise).

34.43 Slope (%)

Expressed as a **percent**, is the difference in elevation divided by the difference in horizontal distance between two points on the surface of a landform. Example: A site slope of one (1) percent is the difference in elevation of one (1) foot (rise) over a horizontal distance of one hundred (100) feet (run).

34.44 Smearing

The mechanical sealing of soil air spaces along an excavated, tilled or compressed surface. This is also referred to as "compacting." In all installations, it is critical to avoid smearing or compacting the soils under and around the field.

34.45 Surface Diversion

A natural or manmade barrier that changes the course of water flow around an onsite system's soil absorption field.

34.46 System Sand Bed

System Sand area required/used in systems. The System Sand bed extends a minimum of 6 in. below, 3 in. above and 6 in. horizontally from the outside edges of all pipes in the system.

34.47 System Sand

System Sand must be clean, granular sand free of organic matter and must adhere to the Presby System Specification with no more than 3% passing the #200 sieve (see complete details in para. 28.0, pg. 18).

34.48 System Sand Extension Area

The System Sand extension area is a minimum of 6 in. deep for Single and 12 in. deep for Multi-Level systems. A System Sand extension area is required on the down slope side of systems sloping more than 10% and extends a minimum of 3 ft. beyond the edge of the System Sand (see illustration in para. 35.0, pg. 29 and para. 16.0, pg. 13).

34.49 Topsoil (a.k.a. Loam or Soil Cover Material)

Topsoil, also known as Loam, is soil material cover capable of sustaining plant growth which forms the topmost layer of cover material above the system.

34.50 Velocity Reducer

Velocity reducer refers to any of the various components whose purpose is to reduce the velocity of effluent flow into the pipes. A distribution box with a baffle or inlet tee is sufficient for velocity reduction in most systems (see illustration in para. 27.4, pg. 18).

35.0 System Diagrams

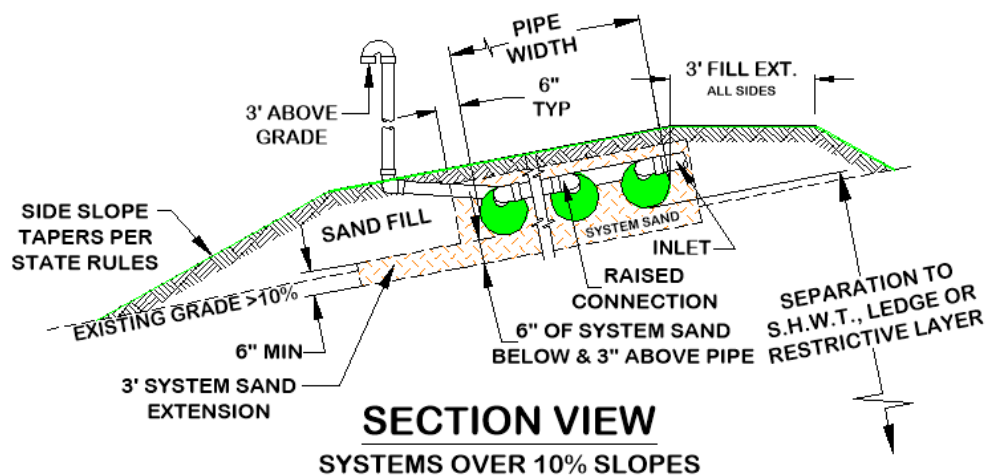
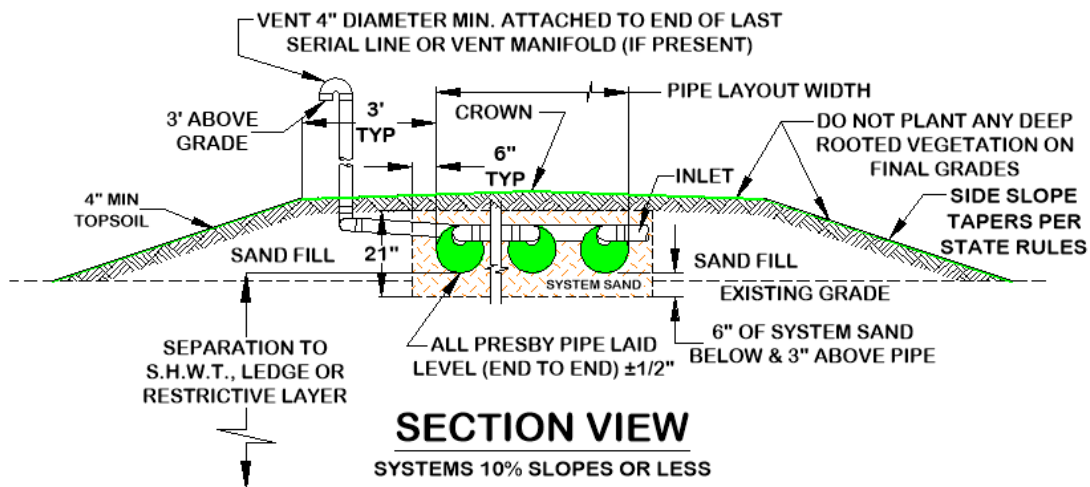
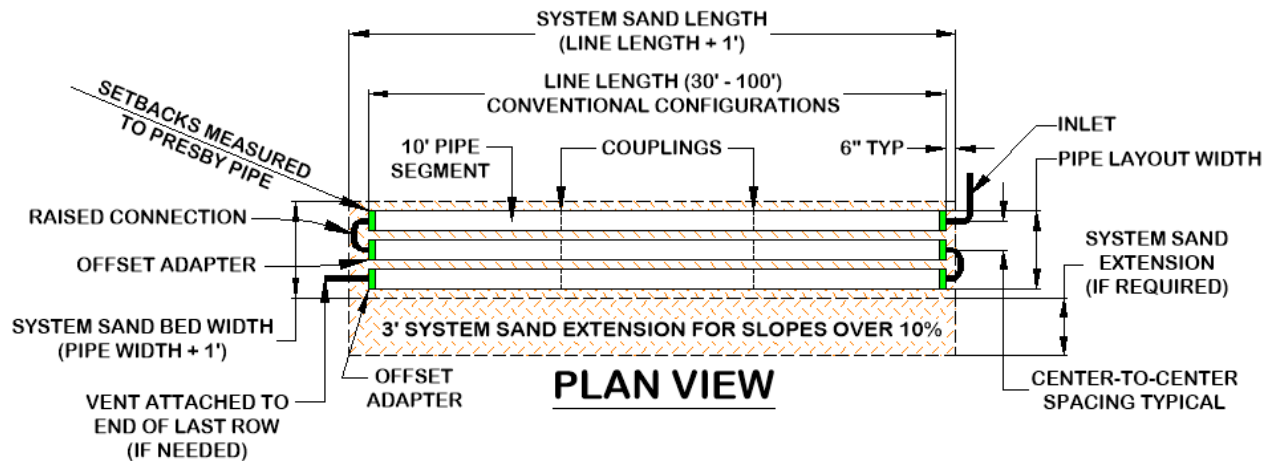

Notes:

1. Advanced Enviro-Septic may be noted as "Advanced E-S" or simply as "AES", Enviro-Septic may be simply noted as "ES".
2. Remove all organics and the "A" horizon before placing system sand or sand fill.
3. Side slope tapers 3:1, except that a slope of 2:1 may be used if necessary to maintain the side slopes on-lot or avoid an existing permanent structure.