

# The Presby Wastewater Treatment System

## ALABAMA

### Design and Installation Manual for Advanced Enviro-Septic® Wastewater Treatment Systems



- ✓ Minimizes the Expense
- ✓ Protects the Environment
- ✓ Preserves the Site

#### AES System in Alabama

1.0 INTRODUCTION	1
1.1 Background	3
1.2 System Components	4
2.0 SYSTEM DESIGN	5
2.1 System Sizing	6
2.2 Design Procedure And Examples	6
2.3 Design Specifications	9
2.4 System Configurations	11
2.5 Pump Systems	14
2.6 Venting	15
3.0 INSTALLATION	18
4.0 REJUVENATION AND EXPANSION	21
5.0 OPERATION AND MAINTENANCE	22



## Presby Environmental, Inc.

An Infiltrator Water Technologies Company  
*The Next Generation of Wastewater Treatment Technology*

143 Airport Road, Whitefield NH 03598

Tel: 800-473-5298 Fax: 603-837-9864

info@presbyeco.com

The information in this Manual is subject to change without notice. We recommend that you check your state's page on our website on a regular basis for updated information. Your suggestions and comments are welcome. Please contact us at:

Presby Environmental, Inc.  
143 Airport Road  
Whitefield, NH 03598  
Phone: 1-800-473-5298 Fax: (603) 837-9864  
Website: [www.presbyenvironmental.com](http://www.presbyenvironmental.com)

The products and methods depicted in this Manual are protected by one or more patents. For more information:  
[www.presbyeco.com/patents](http://www.presbyeco.com/patents)

Advanced Enviro-Septic® is a registered trademark of Presby Environmental Inc.

**IMPORTANT NOTICE:** This Manual is intended ONLY for use in designing and installing Presby Environmental's Advanced Enviro-Septic® Wastewater Treatment Systems. The processes and design criteria contained herein are based solely on our experience with and testing of Advanced Enviro-Septic®. Substitution of any other large diameter gravelless pipe is prohibited.

© Presby Environmental, Inc. October 2019  
All Rights Reserved

## 1.0 INTRODUCTION

### 1.1 Background

The Advanced Enviro-Septic® (AES) Wastewater Treatment System utilizes a unique combination of components that work together to treat effluent and prevent suspended solids from sealing the underlying soil. Comprised of a patented corrugated, perforated plastic pipe with interior skimmer tabs and cooling ridges, the large-diameter pipe retains solids while the Bio-Accelerator® fabric, coarse fibers, and geo-textile fabric provide multiple bacterial surfaces to treat effluent prior to its contact with the receiving soils. The continual cycling of effluent (the rising and falling of liquid inside the pipe) enhances bacterial growth. The AES system is completely passive, and yet provides increased aeration and a greater bacterial treatment area than traditional systems. The result is a system that is more efficient, lasts longer, and has a virtually no negative environmental impact.

The AES system has been successfully tested and certified to NSF/ANSI 40, Class I (a certification typically given to mechanical aeration devices) and BNQ of Quebec Class I, II, III standards.

Additional system benefits include:

- requires a smaller area
- installs easily and quickly
- eliminates the need for environmentally impactful washed stone
- adapts easily to residential, commercial and difficult sites
- prevents formation of organic material at the receiving soil interface
- blends “septic mounds” into sloping terrain
- safely recharges groundwater

#### Environmental Standards and Technical Support

All AES systems shall be designed and installed in compliance with the procedures and specifications detailed in this Manual, the Alabama Department of Public Health’s (ADPH) product permit, and the Alabama Rules. In the event of contradictions between this Manual and the Alabama Rules, Presby Environmental, Inc. (PEI) should be contacted for technical assistance at (800) 473-5298.

#### Certification Requirements

Designers and installers who have not previously attended a PEI certification course are required to obtain certification. Certification is obtained by attending a certification course presented by PEI or its sanctioned representative or by viewing tutorial videos on our website and then successfully passing a short assessment test. PEI recommends professionals involved in the inspection or review of AES systems also become PEI certified.

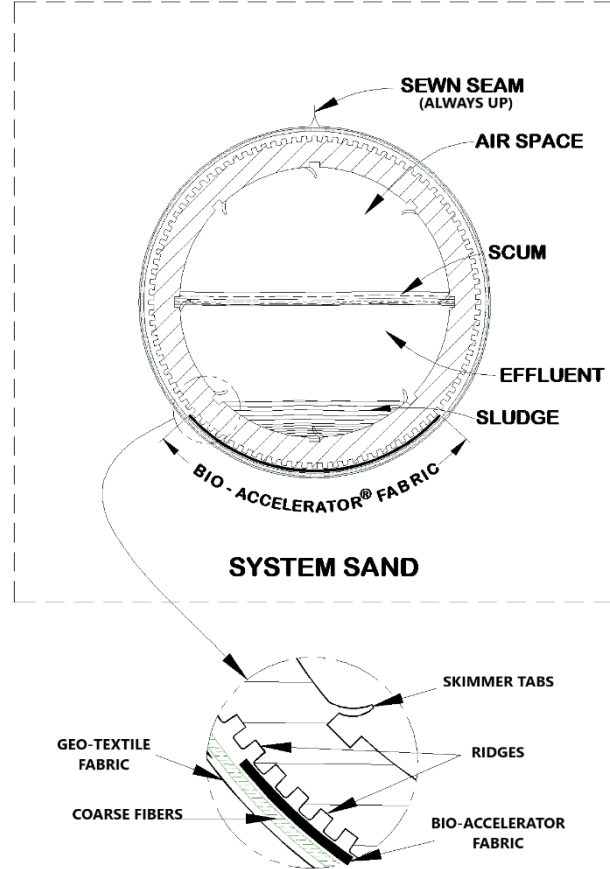

## 1.0 INTRODUCTION

### 1.2 System Components

#### AES Pipe

- nominal exterior diameter of 12in
- holding capacity of 5.8 gallons per foot
- 10 ft length of AES pipe is flexible enough to bend up to 90° and can be cut to any length
- made with a significant amount recycled material



**Offset Adapter** - A 12 in plastic fitting with a single inlet hole oriented in the twelve o'clock position and designed to accept a 4in sewer line, raised connection or vent pipe.

**Double Offset Adapter** - A 12 in plastic fitting with two 4 in holes designed to accept a 4 in inlet pipe, raised connection, vent or vent manifold, and/or bottom drain, depending upon the requirements of the design configuration.

**Coupling** - A plastic fitting used to create a connection between two pieces of AES pipe.

**System Sand** - The system sand that surrounds the AES pipes is an essential component of the system. It is critical that the correct type and amount of system sand is used during construction. System sand shall be coarse to very coarse, clean, granular sand, free of organic matter. System sand is placed a minimum of 3 in above and 6 in below, between, and around the outer perimeter of the AES pipes. The sand bed may extend up to 5 ft beyond the ends of the AES rows. System sand shall adhere to all of the following percentage and quality restrictions:

**System Sand Specification**

Sieve Size	Percent Retained on Sieve (by weight)
3/4 in (19 mm)	0
#10 (2 mm)	0 - 35
#35 (0.50 mm)	40 - 90
Note: not more than 3% allowed to pass the #200 sieve (verified by washing sample per requirements of ASTM C-117)	

#### System Sand Bed Height Dimension

The height of an AES sand bed measures 21 in minimum (not including cover material):

- minimum of 6 in of system sand below the AES pipe;
- 12 in diameter of the pipe;
- minimum of 3 in of system sand above the AES pipe; when a bed slopes over 5%, a minimum 2.5 ft system sand extension area is required and shall be a minimum of 6 in deep.

**System Sand Acceptable Alternative** - ASTM C-33 (concrete sand), natural or manufactured sand, with not more than 3% passing the #200 sieve (verified by washing the sample per the requirements of ASTM C-117 as noted in the ASTM C-33 specification) may be used as an acceptable alternate material for use as system sand.

**Sand Fill** - Sand fill may be used to raise the elevation of the system in order to meet the required separation distance from the SHWT or restrictive feature or in side-slope tapers. No organic material or stones larger than 6 in are allowed in the sand fill. System sand may be used in place of sand fill.

## 2.0 SYSTEM DESIGN

### 2.1 System Sizing

#### AES Pipe Requirement

- Residential systems: 70 ft per br.
- Non-residential/commercial systems comprised of residential strength effluent: 2.14 gpd per ft.

**Table A: System Sand Bed Area and Bed Configuration Requirements**

Percolation Rate (mpi)	Soil Group & USDA Textures	Bed Loading Rate (gpd/sf)
1 - 15	Group 1	1.50
16 - 30	Group 2	1.00
31 - 60	Group 3	0.71
61 - 75	Group 4a	0.36
76 - 90		0.28
91 - 120	Group 4b	0.28
121-240	Group 5b	Per State Rules Appendix A, Tables 3 & 3a: Field Sizing for Establishments or Large Flow Systems with Secondary Treated Effluent

**Table B: System & Site Slope Limitations and Allowed Bed Configurations**

Percolation Rate Minutes per Inch (mpi)	System Slope Max (%)	Site Slope Max (%)
15 or less	25%	33%
16-30	20%	25%
31-60	15%	20%
61-240	Level	10%

**Table C: Row Length and Pipe Layout Width**

		Total Linear Feet of AES Pipe													
Row Length (ft)	20	40	60	80	100	120	140	160	180	200	220	240	260	280	300
	25	50	75	100	125	150	175	200	225	250	275	300	325	350	375
	30	60	90	120	150	180	210	240	270	300	330	360	390	420	450
	35	70	105	140	175	210	245	280	315	350	385	420	455	490	525
	40	80	120	160	200	240	280	320	360	400	440	480	520	560	600
	45	90	135	180	225	270	315	360	405	450	495	540	585	630	675
	50	100	150	200	250	300	350	400	450	500	550	600	650	700	750
	55	110	165	220	275	330	385	440	495	550	605	660	715	770	825
	60	120	180	240	300	360	420	480	540	600	660	720	780	840	900
	65	130	190	260	325	390	455	520	585	650	715	780	845	910	975
	70	140	210	280	350	420	490	560	630	700	770	840	910	980	1050
	75	150	225	300	375	450	525	600	675	750	825	900	975	1050	1125
	80	160	240	320	400	480	560	640	720	800	880	960	1040	1120	1200
	85	170	255	340	425	510	595	680	765	850	935	1020	1105	1190	1275
	90	180	270	360	450	540	630	720	810	900	990	1080	1170	1260	1350
95	190	285	380	475	570	665	760	855	950	1045	1140	1235	1330	1425	
100	200	300	400	500	600	700	800	900	1000	1100	1200	1300	1400	1500	
# of Rows	2	3	4	5	6	7	8	9	10	11	12	13	14	15	
Spacing (ft)	1.50	2.50	4.00	5.50	7.00	8.50	10.00	11.50	13.00	14.50	16.00	17.50	19.00	20.50	22.00
	1.75	2.75	4.50	6.25	8.00	9.75	11.50	13.25	15.00	16.75	18.50	20.25	22.00	23.75	25.50
	2.00	3.00	5.00	7.00	9.00	11.00	13.00	15.00	17.00	19.00	21.00	23.00	25.00	27.00	29.00
	2.25	3.25	5.50	7.75	10.00	12.25	14.50	16.75	19.00	21.25	23.50	25.75	28.00	30.25	32.50
	2.50	3.50	6.00	8.50	11.00	13.50	16.00	18.50	21.00	23.50	26.00	28.50	31.00	33.50	36.00
	2.75	3.75	6.50	9.25	12.00	14.75	17.50	20.25	23.00	25.75	28.50	31.25	34.00	36.76	39.50
	3.00	4.00	7.00	10.00	13.00	16.00	19.00	22.00	25.00	28.00	31.00	34.00	37.00	40.00	43.00
Pipe Layout Width (ft)															

## 2.0 SYSTEM DESIGN

### 2.2 Design Procedure and Examples

**Step #1:** Calculate the Minimum Amount of AES Pipe Needed

a) Residential: Multiply the number of bedrooms times 70 ft of AES pipe per bedroom (two bedrooms minimum).

b) Commercial: Systems with normal strength effluent are calculated by dividing the daily design flow by 2.14 gpd/ft of AES pipe. (Contact Technical Support for high strength wastewater.)

**Step #2:** Calculate System Sand Bed Area (SSBA)

From Table A: Find the bed loading rate using the percolation rate or soil's texture and calculate the minimum system sand bed area (SSBA). Divide the daily design flow (gpd) by the bed loading rate (each bedroom is calculated at 150 GPD).

**Step #3:** Determine Bed Configuration and System Slope

From Table B: Choose an allowable system slope and bed configuration using the soil's percolation rate.

**Step #4:** Determine Number of Serial Sections Needed

If designing with serial distribution, calculate the minimum number of serial sections required. Divide the daily design flow by 600 gpd and round up to nearest whole number. This step may be skipped when using a parallel layout or with systems with a percolation rate over 60 mpi.

**Step #5:** Determine Number of Rows Needed

Select a row length suitable for the site and calculate the number of rows needed: Take the minimum amount of pipe required from Step #1 and divide by the selected row length, then round up to a whole number. The number of rows must be evenly divisible by the number of serial sections required (add rows as necessary).

**Step #6:** Choose a System Sand Bed Length (SSBL) that is:

a) At least the row length from Step #5 plus one ft.

b) No longer than the row length from Step #5 plus 10 ft.

**Step #7:** Determine the Pipe Layout Width (PLW)

Find the PLW from Table C using a 1.5 ft minimum center-to-center row spacing (larger spacing allowed, but not required).

**Step #8:** Determine System Sand Bed Width (SSBW)

Calculate the minimum SSBW by dividing the SSBA from Step #2 by the SSBL from Step #6.

**Step #9:** Verify the Minimum SSBW Will Cover all the AES Pipe Rows

a) Beds sloping 5% or less: If the minimum SSBW is less than the (PLW + 1 ft), use (PLW + 1 ft) as the new minimum SSBW.

b) Beds sloping > 5%: If the minimum SSBW is less than the (PLW + 3.5 ft), use (PLW + 3.5 ft) as the new minimum SSBW.

**Step #10:** Determine System Sand Extensions (SSE)

a) Level Beds: SSEs are evenly divided and placed on each side of AES pipes =  $[SSBW - (PLW + 1)] \div 2$ . There will be no SSE's if the SSBW = (PLW + 1 ft).

b) Sloping Beds: SSE is placed entirely on the down slope side of the bed =  $SSBW - (PLW + 1)$  and must be at least 2.5 ft (3 ft from the edge of the AES pipe) if system slope is > 5%.

## 2.0 SYSTEM DESIGN

**Design Example #1 - Single Family Residence, 4 bedrooms (600 gpd), percolation rate of 12 mpi, level site, basic serial system, system entirely below grade.**

*Step #1: Calculate the Minimum Amount of AES Pipe Needed*

AES pipe required = (4) bedrooms x 70 ft / bedroom = 280 ft minimum.

*Step #2: Calculate System Sand Bed Area (SSBA)*

Bed loading rate from Table A = 1.50 GPD/ft<sup>2</sup>; SSBA = 600 GPD ÷ 1.50 GPD/ft<sup>2</sup> = 400 ft<sup>2</sup> minimum.

*Step #3: Determine Bed Configuration and System Slope*

Table B allows up to 25% system slope for 12 mpi, however our system will be level.

*Step #4: Determine Number of Serial Sections Needed*

This step is not required for systems with daily flows of 600 gpd or less. Skip to Step #5.

*Step #5: Determine Number of Rows Needed*

Select 70 ft (as the minimum amount of AES pipe needed – 280 ft – is evenly divided by 70)  
280 ft ÷ 70 ft per row = 4 rows.

*Step #6: Choose a System Sand Bed Length (SSBL)*

a) Minimum = 70 ft row length + 1 ft = 71 ft.

b) Maximum = 70 ft row length + 10 ft = 80 ft.

Use 71 ft as the sand bed length.

*Step #7: Determine the Pipe Layout Width (PLW)*

Table C shows a Pipe Layout Width (PLW) of 4 ft when using 70 ft long rows spaced at 1.5 ft center-to-center.

*Step #8: Determine System Sand Bed Width (SSBW)*

Minimum SSBW = 400 ft<sup>2</sup> ÷ (70 ft + 1 ft) = 5.64 ft.

*Step #9: Verify the Minimum SSBW Will Cover all the AES Pipe Rows*

a) 5.64 ft SSBW is less than 5.5 ft + 1 = 6.5 ft Use the PLW + 1 ft as the minimum SSBW.

b) Bed does not slope greater than 5%, this step is not required.

*Step #10: Determine System Sand Extensions (SSE)*

a)  $[6.5 \text{ ft} - (5.5 + 1)] \div 2 = 0$  there are no System Sand extensions because the System Sand bed width from Step #9 is equal to the PLW + 1 ft.

b) Not a sloping bed, this step is not required.

Illustration of Example #1, basic serial distribution:

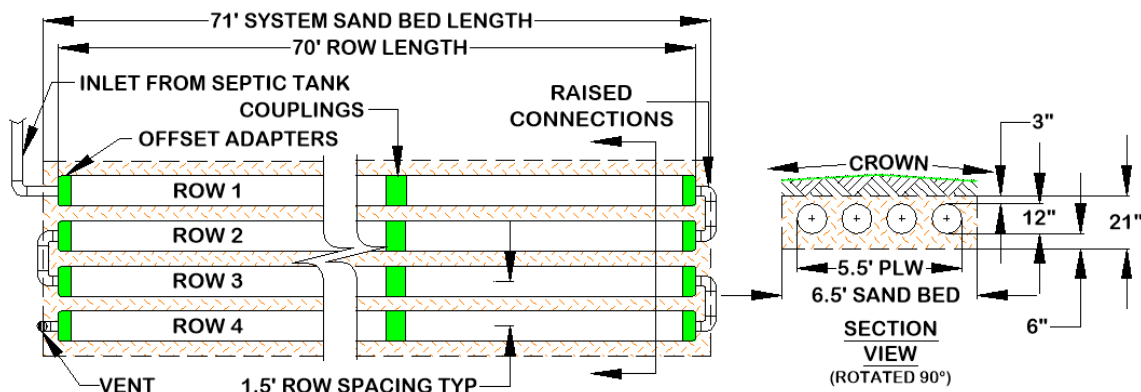

## 2.0 SYSTEM DESIGN

**Design Example #2 - Commercial system using 1,000 gpd, normal strength effluent, 25 mpi soils, 10% sloping terrain, use sloping bed if possible, system entirely below grade.**

*Step #1: Calculate the Minimum Amount of AES Pipe Needed.*

AES pipe required =  $1,000 \text{ gpd} \div 2.14 \text{ gpd/ft.} = 468 \text{ ft.}$  minimum. (Round up to 480 for ease of construction.)

*Step #2: Calculate System Sand Bed Area (SSBA)*

Bed loading rate from Table A =  $1.00 \text{ GPD/ft}^2$ ; SSBA =  $1000 \text{ GPD} \div 1.00 \text{ GPD/ft}^2 = 1000 \text{ ft}^2$  minimum.

*Step #3: Determine Bed Configuration and System Slope*

Table B allows up to 20% system slope for 12 mpi, our system will only slope 10%.

*Step #4: Determine Number of Serial Sections Needed*

Serial sections required:  $1,000 \text{ GPD} \div 600 = 1.7$ , round up to 2.

*Step #5: Determine Number of Rows Needed*

a) Using a row length of 80 ft. requires six rows ( $480 \text{ ft.} \div 80 \text{ ft.} = 6$ ).

b)  $6 \text{ rows} \div 2 \text{ serial section} = 3 \text{ rows per section.}$

*Step #6: Choose a System Sand Bed Length (SSBL)*

a) Minimum =  $80 \text{ ft row length} + 1 \text{ ft} = 81 \text{ ft.}$

b) Maximum =  $80 \text{ ft row length} + 10 \text{ ft} = 90 \text{ ft.}$

Use 81 ft as the sand bed length.

*Step #7: Determine the Pipe Layout Width (PLW)*

Table C shows a pipe layout width (PLW) of 8.5 ft when using 80 ft long rows spaced at 1.5 ft center-to-center.

*Step #8: Determine System Sand Bed Width (SSBW)*

Minimum SSBW =  $1000 \text{ ft}^2 \div (80 \text{ ft} + 1 \text{ ft}) = 12.34 \text{ ft}$  (Round up to 12.5 for ease of construction).

*Step #9: Verify the Minimum SSBW Will Cover all the AES Pipe Rows*

a)  $12.5 \text{ ft SSBW}$  is greater than  $8.5 \text{ ft} + 1 = 9.5 \text{ ft.}$  Use 12.5 as the minimum SSBW.

b) Bed is sloping over 5% so verify  $12.5 \text{ ft SSBW}$  is equal to or greater than  $(\text{PLW} + 3.5 \text{ ft})$ ;  $8.5 + 3.5 = 12 \text{ ft}$ ; the system sand bed width does not need to be increase.

*Step #10: Determine System Sand Extensions (SSE)*

a) Bed slopes 10% go to step b).

b) The bed is sloping over 5% so the system sand extension is placed entirely on the down slope side of the field and is = to  $12.5 \text{ ft}$  (from Step #9 a) –  $(8.5 \text{ PLW} + 1 \text{ ft}) = 3 \text{ ft.}$

Illustration of Example #2, combination serial distribution:

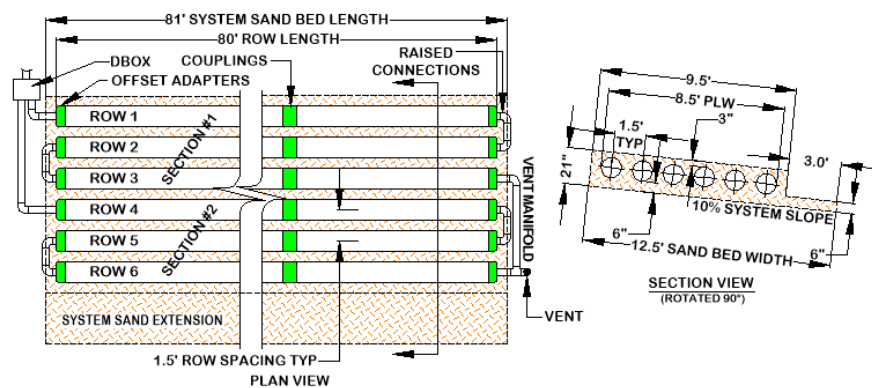



## 2.0 SYSTEM DESIGN

### 2.3 Design Specifications

The AES system shall be designed in accordance with this Manual and Alabama Rules. The AES can be installed utilizing any of the design configurations outlined in this Manual. Non-compliant design configurations may be permitted with a State waiver.

#### Daily Design Flow

Residential daily design flow for AES systems is calculated in accordance with the Alabama Rules. Systems servicing more than two residences shall use the commercial specifications detailed in the sizing tables. The minimum daily design flow shall be two bedrooms for any single-family residential system and 300 gpd for any commercial system.

#### Water Purification Systems

- Water purification systems and water softeners should not discharge into any AES system.
- If there is no alternative means of disposing of this backwash other than in the AES system, the AES system will need to be “oversized.” Calculate the total amount of backwash in gpd, multiply by 3, and add this amount to the daily design flow when determining the field and septic tank sizing.
- No additional AES pipe is required when using a garbage disposal (grinder). Multiple compartment septic tanks or multiple tanks are preferred and should be pumped as needed.

#### Effluent (Wastewater) Strength

The AES pipe requirement for bed or trench systems is based on residential strength effluent, which has received primary treatment provided by a rules-compliant septic tank. Designing a system that will treat higher strength wastes requires additional AES pipe. In these situations, our Technical Advisors shall be consulted for recommendations at (800) 473-5298.

#### Filters and Baffles

- Effluent filters are not recommended for use with AES systems.
- If used, effluent filters shall be maintained on at least an annual basis. Follow manufacturer’s instructions regarding required inspections, cleaning and maintenance of the effluent filter.
- Effluent filters must allow the free passage of air to ensure the proper functioning of the system.
- All septic tanks shall be equipped with baffles to prevent excess solids from entering the AES system.
- Charcoal filters in vent stacks (for odor control) are not recommended by PEI. They can block air flow and potentially shorten system life.

#### Flow Equalizers Required

All distribution boxes used to divide effluent flow require flow equalizers in their outlets. A flow equalizer is an adjustable plastic insert installed in the outlet holes of a distribution box to equalize effluent distribution to each outlet whenever flow is divided. Each bed or section of combination serial distribution is limited to a maximum of 15 gallons per minute (gpm), due to the flow constraints of the equalizers. Example: pumping to a combination system with 3 sections (using 3 D-box outlets). The maximum delivery rate is  $(3 \times 15) = 45$  gpm. All systems with combination serial distribution or multiple bed distribution shall use flow equalizers in each distribution box outlet.



#### Two-Inch Rule

The outlet of a septic tank or distribution box shall be set at least 2 in above the highest inlet of the AES row, with the connecting pipe slope not less than 1% (approximately 1/8 in per foot). Illustration of two-inch rule:

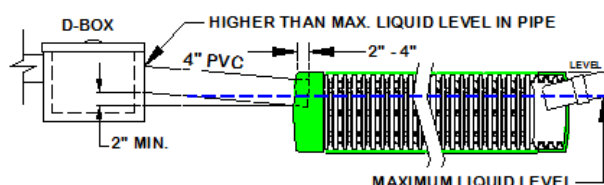

## 2.0 SYSTEM DESIGN

### AES Pipe Requirement

AES systems use the bed sizing tables, pipe and installation requirements noted in this Manual.

- Residential systems: 70 ft per br.
- Non-residential/commercial systems comprised of residential strength effluent: 2.14 gpd per ft.

### Row Requirements

- All beds shall have at least 2 rows.
- Maximum row length for any system is 100 ft of pipe.
- Recommended minimum row length is 30 ft of pipe.
  - A combination (or D-box) distribution system shall be used if any row length is less than 30 ft. The D-box shall feed at least 30 ft of AES pipe, a minimum of two D-box outlets must be used and the field must be vented.
- Minimum center-to-center spacing is 1.5 ft for all systems. Spacing may be increased at the discretion of the system designer or as needed to meet the required SSBA.
- For level beds: the AES rows shall be centered in the middle of the system sand bed area and any system sand extensions divided evenly on both sides.
- For sloping beds: for beds with slopes of greater than 5%, the elevations for each AES row must be provided on the drawing. All rows shall be grouped at the high side of the SSBA with any system sand extensions placed entirely on the downslope side.
- Sewn seam must be oriented in the 12 o'clock position. This correctly orients the Bio-Accelerator® fabric in the 6 o'clock position.
- Each row must be laid level to within  $\pm 1/2$  in (total of 1 in) of the specified elevation and preferably should be parallel to the contour of the site.
- It is most convenient if row lengths are designed in exact 10 ft increments to accommodate the length of the AES pipe as manufactured. However, AES pipe lengths can be cut to any length.

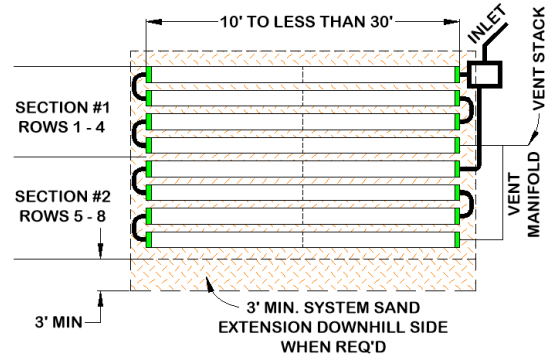

### Pressure Distribution

The use of pressure distribution lines in AES systems is prohibited. Pumps may be utilized when necessary only to feed a distribution box which then distributes effluent by gravity to the AES field.

### System Sand Extensions

System sand extensions are placed on the down slope side of sloping systems and equally divided on each side of level systems. The system sand extension is measured from the tall portion of the system sand bed. In systems sloping more than 5%, a 2.5 ft minimum system sand extension is required. The system sand extension area is a minimum of 6 in deep. For multiple slope beds, if any portion of the bed has a system slope greater than 5% a system sand extension is required.

### Sloping Sites and Sloping Mound Systems

- The percentage of slope in all system drawings refers to the slope of the system, not the existing terrain ("site slope") and refers to the slope of the bed itself ("system slope").
- The system slope and the site slope do not have to be the same.
- Maximum site slope is 33% and maximum system slope is 25% (without a State waiver).

### Separation Distances (Horizontal and Vertical)

Separation distances to the seasonal high-water table (SHWT) or other restrictive features are measured from the outermost edge of the system sand.

### Barrier Materials over System Sand

No barrier materials (hay, straw, tarps, etc.) are to be placed between the system sand and cover material.

## 2.0 SYSTEM DESIGN

### 2.4 System Configurations

#### Elevated Bed Systems (Mounds)

Elevated bed systems are not allowed by the current Alabama Rules and will be required to comply with a 420-3-1-.88 Hardship Variance. Elevated AES beds are designed for sites with soil, depth to groundwater or restrictive feature constraints that do not allow for in-ground bed systems. An elevated bed system is a soil absorption field with the bed bottom located at least 6 inches above the original grade. Bed bottom elevations from the original grade to less than 6 inches above the original grade are not allowed. Elevated bed systems require side-slope tapering of the fill and topsoil covering the bed. These must conform to the fill extension requirements in Section 3.0 on page 20).

Side slope tapering begins 6 inches from the edge of the AES pipe and is to be no steeper than 2:1. If the bed slopes, a 3:1 side slope taper is to be used on the down slope side of the field. Always maintain 12 inches of material cover over the end of any system sand extension (if present). Illustration of an elevated level bed:

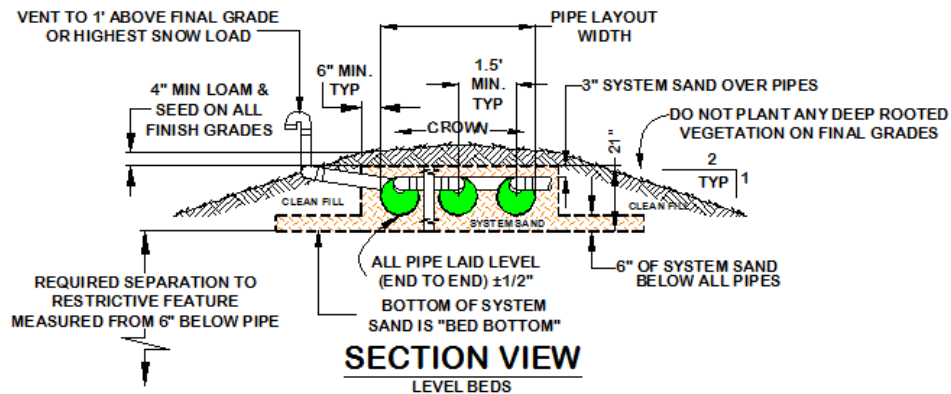

#### In-Ground Bed Systems

Systems are installed below existing grade for sites with no soil restrictive features to limit placement. In-ground systems that slope over 5% require a 2.5 ft system sand extension on the downhill side of the field. In-ground on level site:

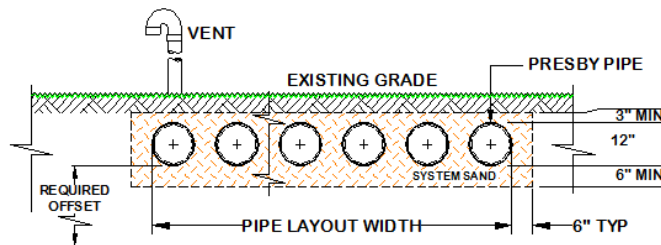

#### Basic Serial Distribution

AES rows are connected in series at the ends with raised connections, using offset adapters.

- Used for single beds of 600 gpd or less.
- Incorporates rows in serial distribution in a single bed.
- Rows shall meet requirements outlined in the design criteria above.
- Gravity fed basic serial systems may be fed directly from the septic tank.
- For sloping beds, a system sand extension (if needed/required) is placed entirely on the downhill side and must be at least 2.5 ft for beds that slope over 5%.
- Bed may be constructed with unusual shapes to avoid site obstacles or meet setback requirements.



## 2.0 SYSTEM DESIGN

Illustration of basic serial systems bed designs:

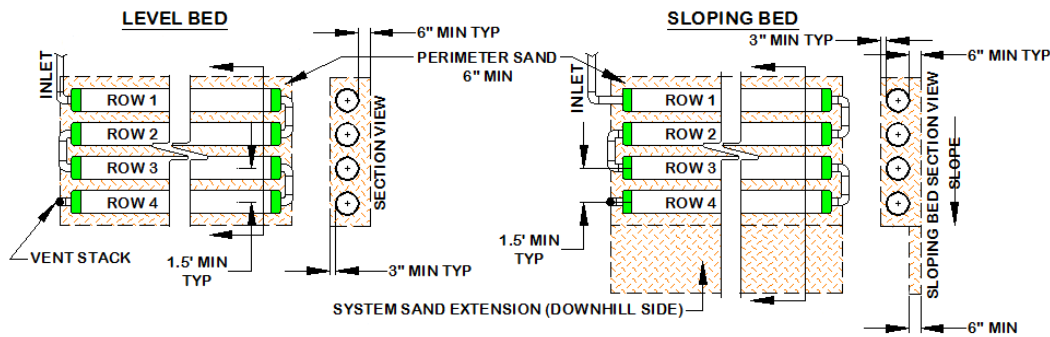

### Butterfly Configuration

- A “butterfly configuration,” is considered a single bed system with two or more sections extending in opposite directions from the D-box along the contour.
- Butterfly configurations are generally used to accommodate bed lengths longer than the maximum row length of 100 ft.
- Beds can contain any number of serial sections.
- Rows shall meet requirements outlined in the design criteria above.

Illustration of a butterfly configuration bed design:

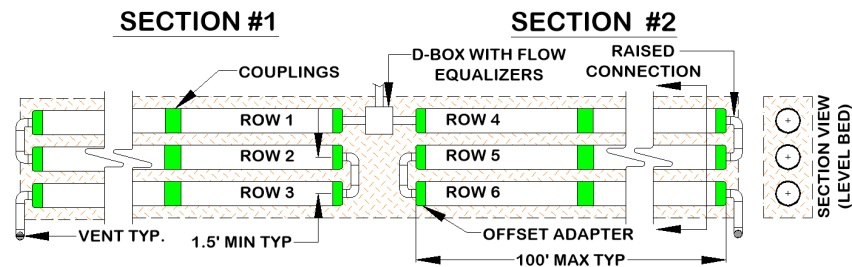

### Combination Serial Distribution

Combination serial distribution within one bed, or multiple beds, is required for systems with daily design flows greater than 600 gpd. Effluent flow is divided evenly to each section using a distribution box with flow equalizers.

- Consists of two or more serial sections (with a maximum loading of 600 gpd/section) installed in a single bed.
- Each section consists of a series of AES rows connected at the ends with raised connections, using offset adapters and PVC sewer and drainpipe.
- There is no limit on the number of sections within a bed.
- Each section shall have the same linear feet of pipe determined by dividing the total linear feet required in the system by the number of sections required.
- When the vent manifold is on the same side as the serial section inlets, the manifold runs over the top of these inlets (as shown in illustration).

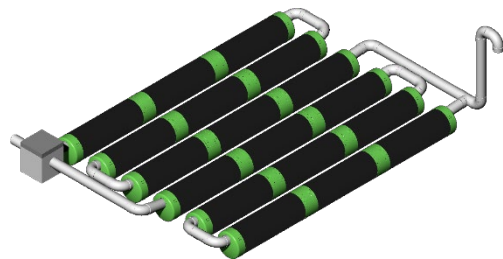

## 2.0 SYSTEM DESIGN

Rows must meet requirements outlined in the design criteria above except rows within a section may vary in length to accommodate site constraints as shown below. Illustrations of combination serial systems:

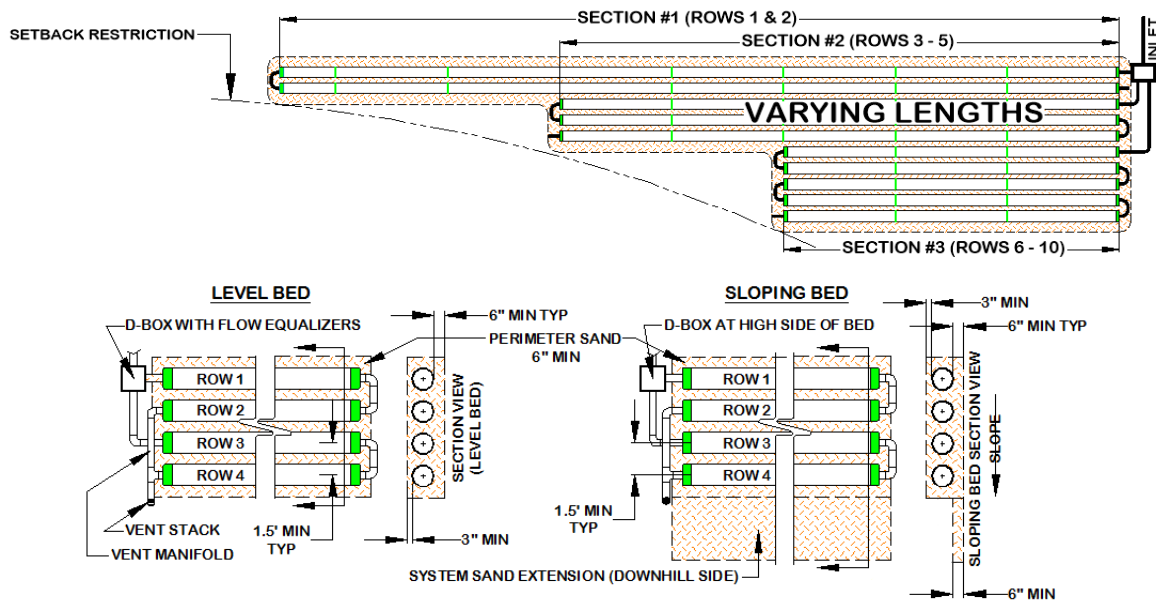

### D-box (Parallel) Distribution

- All rows in this configuration must be the same length.
- Flow equalizers must be used in the D-box.
- Use a manifold to connect the ends of all rows. Manifold shall be sloped toward AES pipes.
- D-box placement shall be installed on level, firmly compacted soil.
- All rows shall be laid level end-to-end.
- A 2 in min. drop is required between the D-box outlets and the AES pipe inlets.
- Rows shall meet requirements outlined in the design criteria above.

Illustrations for D-box (parallel) distribution bed design:

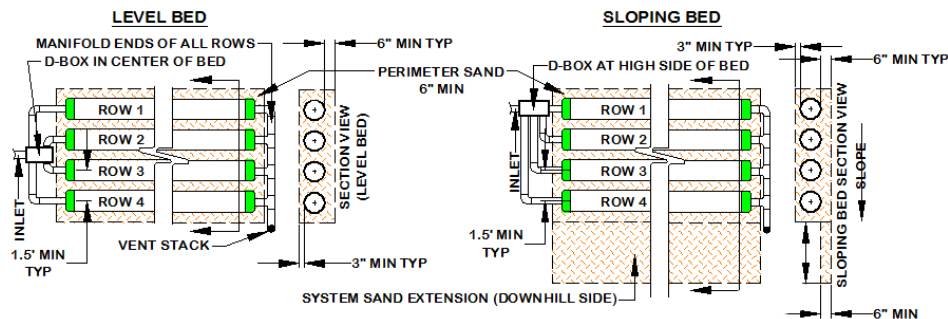

### Multiple Bed Distribution

Incorporates two or more beds, each bed receiving an equal amount of effluent from a D-box. Multiple beds may be oriented along the contour of the site or along the slope of the site.

- Each bed shall have the same minimum linear feet of pipe. The minimum linear feet of pipe per bed is determined by dividing the total linear feet required in the system by the number of beds.
- Rows within a bed may vary in length to accommodate site constraints, except with D-box configuration which requires all rows to be the same length.
- End-to-end configurations are preferred to side-to-side configurations.
- Bed separation distance is measured from pipe to pipe.

## 2.0 SYSTEM DESIGN

Illustration of End-to-End multiple beds:

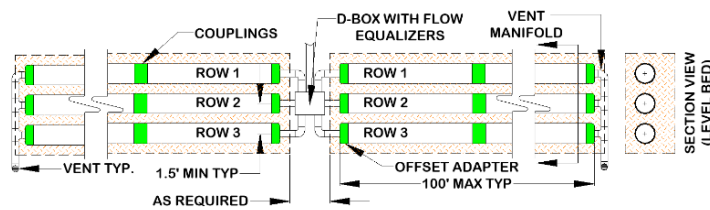
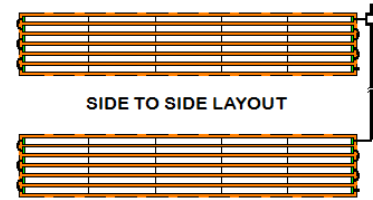

Illustration of Side-to-Side multiple beds:



### Angled and Curving Beds

Angled and curving beds are used to avoid obstacles and work well around structures, setbacks, and slopes. Multiple curves can be used within a system to accommodate various contours of the site.

- Rows are angled by bending pipes up to 90 degrees or through the use of offset adapters
- Rows shall meet requirements outlined in the design criteria above.

## 2.5 Pump Systems

Pumped systems supply effluent to the system using a pump and distribution box when site conditions do not allow for a gravity system. Dosing siphons are also an acceptable means of delivering effluent to the system.

- Pump volume per dose shall be no greater than 1-gallon times the total linear feet of AES pipe.
- Pump dosing should be designed for a minimum of 6 cycles per day.
- If possible, the dosing cycle should provide one hour of drying time between doses.
- Pump systems must have a high-water alarm float or sensor installed inside the pump chamber.
- Pumped systems with basic serial distribution are limited to a maximum dose rate of 40 gpm and do not require the use of a flow equalizer on the D-box outlet.
- All pump systems require differential venting.
- All systems with combination serial distribution or multiple bed distribution shall use flow equalizers in each distribution box outlet with each bed or section limited to a maximum of 15 gpm, due to the flow constraints of the equalizers.
  - Example: pumping to a combination system with 3 sections (using 3 D-box outlets). The maximum delivery rate is  $(3 \times 15) = 45$  gpm. Higher flow rates can be accommodated by connecting multiple D-box outlets to each line.
- The rate at which effluent enters the AES pipe shall be controlled. Excessive effluent velocity can disrupt solids that settle in the pipes.
  - Effluent shall never be pumped directly into AES pipes.
  - A distribution box or tank shall be installed between the pumping chamber and the AES pipe to reduce effluent velocity.
  - Force mains shall discharge into a distribution box (or equivalent) with velocity reducer and a baffle, 90° bend, tee or equivalent.

Two methods of velocity reduction:

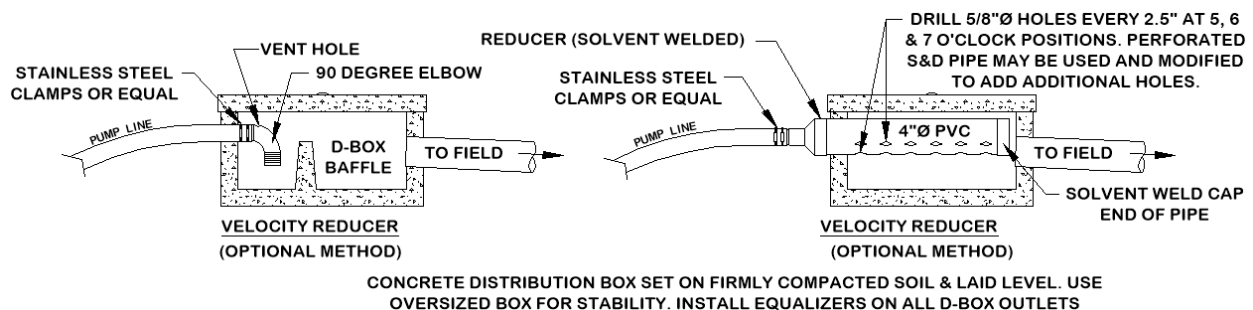

## 2.0 SYSTEM DESIGN

### 2.6 Venting

An adequate air supply is essential to the proper functioning of AES systems. Venting is always required. All systems shall utilize differential venting.

#### General Rules

- Differential venting is the use of high and low vents in a system.
- In a gravity system, the roof stack acts as the high vent.
- High and low vent openings shall be separated by a minimum of 10 vertical ft.
- If possible, the high and low vents should be of the same capacity.
- Vent openings shall be located to ensure the unobstructed flow of air through the entire system.
- The low vent inlet shall be a minimum of 1 ft above final grade or anticipated snow level.
- Sch. 40 or SDR 35 PVC (or equivalent) should be used for all vent stacks.
- One 4 in vent is required for every 1,000 ft of AES pipe.
- A single 6 in vent may be installed in place of up to three 4 in vents.
- If a vent manifold is used, it shall be at least the same diameter as the vent(s).
- Vent piping should slope downward toward the system to prevent moisture from collecting in the pipe and blocking the passage of air.
- Remote venting may be utilized to minimize the visibility of vent stacks.
- When venting multiple beds, it is preferred that each bed be vented separately rather than connecting bed vents together. Multiple vents can be remotely located to the same location if desired.

#### Vent Manifolds

A vent manifold may be incorporated to connect the ends of a number of sections or rows of AES pipe to a single vent opening. Slope the lines connecting the manifold to the AES pipes to drain condensation.

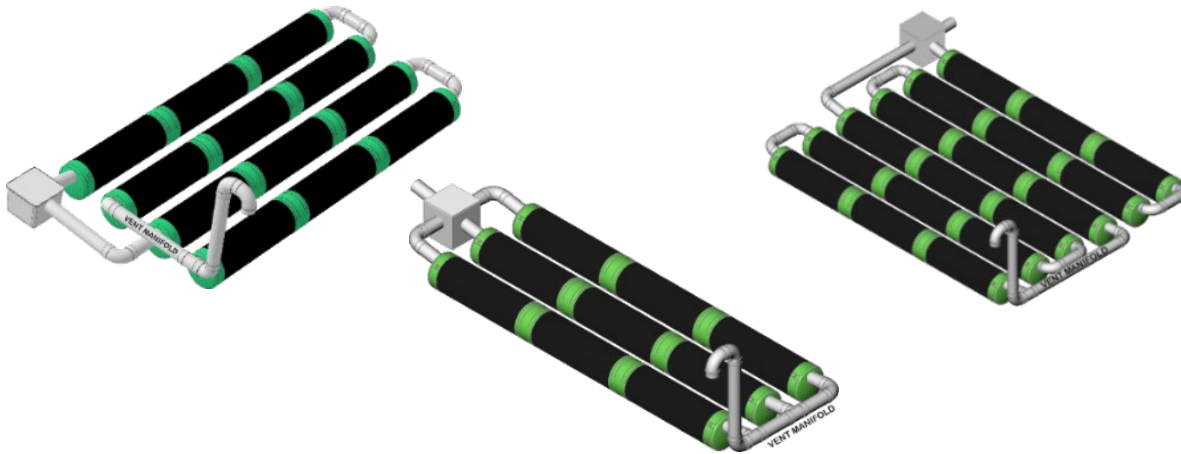

#### Gravity Systems Vent Locations

- A low vent is installed at the end of the last row of each section or the end of the last row in a basic serial bed, or at the end of each row in a D-box distribution configuration system. A vent manifold may be used to connect the ends of multiple sections or rows.
- The house (roof) vent functions as the high vent as long as there are no restrictions or other vents between the low vent and the house (roof) vent.
- When the house (roof) vent functions as the high vent, there shall be a minimum of a 10 ft vertical differential between the low and high (roof) vent openings.

## 2.0 SYSTEM DESIGN

Illustration of gravity system air flow:

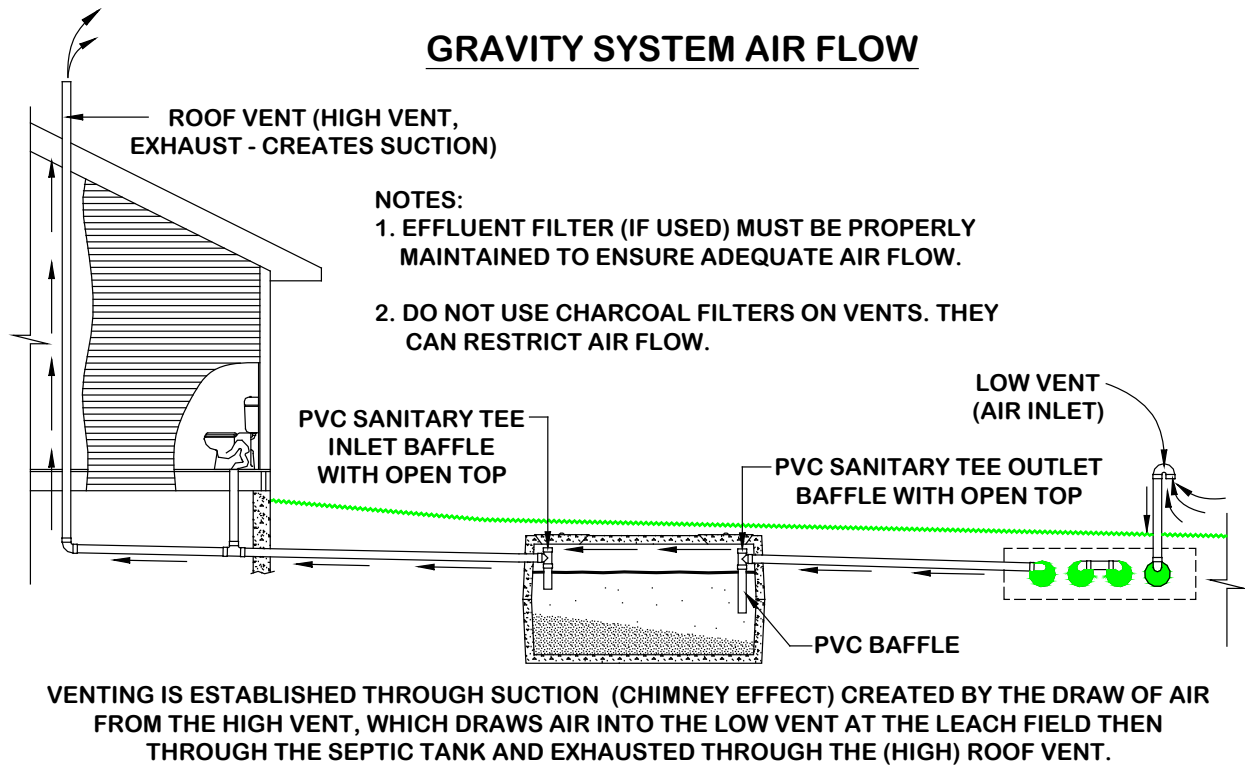

### Pump System Vent Locations

- A low vent is installed through an offset adapter at the end of each section, basic serial bed or attached to a vent manifold.
- A high vent is attached to an unused distribution box outlet.
- The low and high vents may be swapped, provided the distribution box is insulated against freezing in cold climates.
- For options to relocate the high vent, see Remote Venting.
- For options to eliminate the high vent, see Bypass Venting.

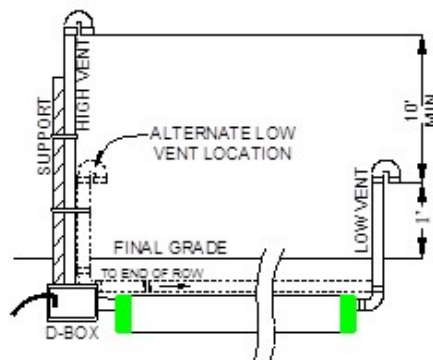



## 2.0 SYSTEM DESIGN

### Remote Venting

If site conditions do not allow the vent pipe to slope toward the system, or the owner chooses to utilize remote venting for aesthetic reasons (causing the vent pipe not to slope toward the system), the low point of the vent line must be drilled creating several 1/4 in holes to allow drainage of condensation. This procedure may only be used if the vent pipe connecting to the system has:

- A high point that is above the highest point of all AES pipes or the D-box; and,
- A low point opened for drainage which is above the SHWT. (See diagram below.)

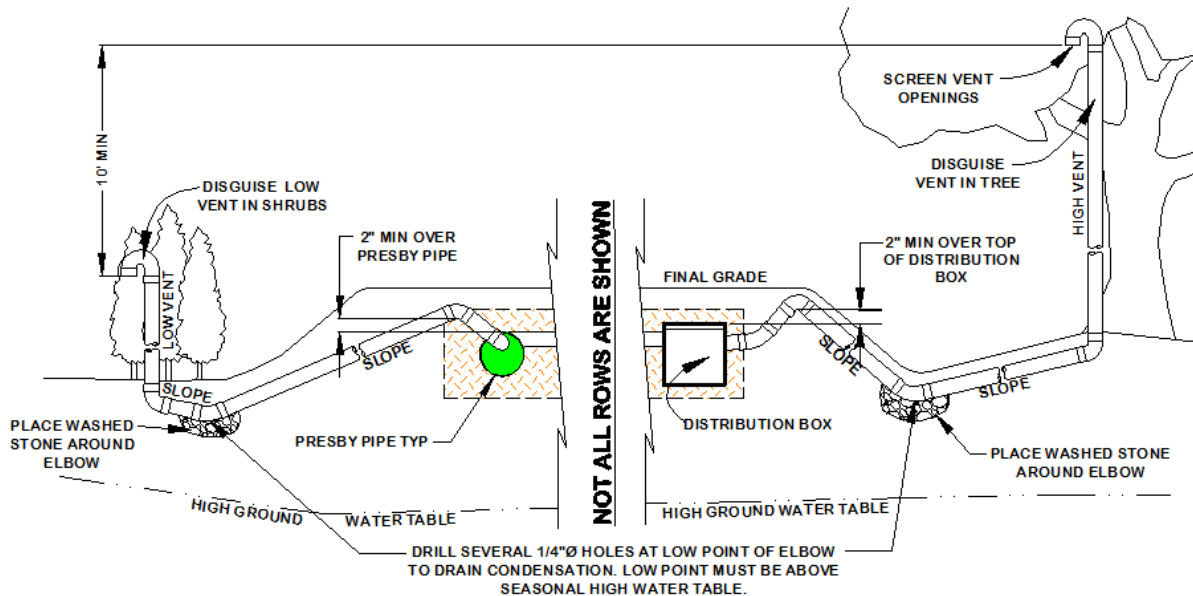

### By-Pass Venting

When a field is fed using pumping or dosing, it is necessary to provide air flow through the system by using "by-pass venting." In by-pass venting, the system is plumbed by attaching Sch. 40 or SDR 35 PVC to the D-box back to the septic tank or pump chamber if no effluent filter. This process "by-passes" the pump line and allows air to flow from the low vent to the roof vent which acts as the high vent. Bypass vent line invert must rise 2 in above D-box before dropping to pump chamber or septic tank.

Illustration of by-pass venting:

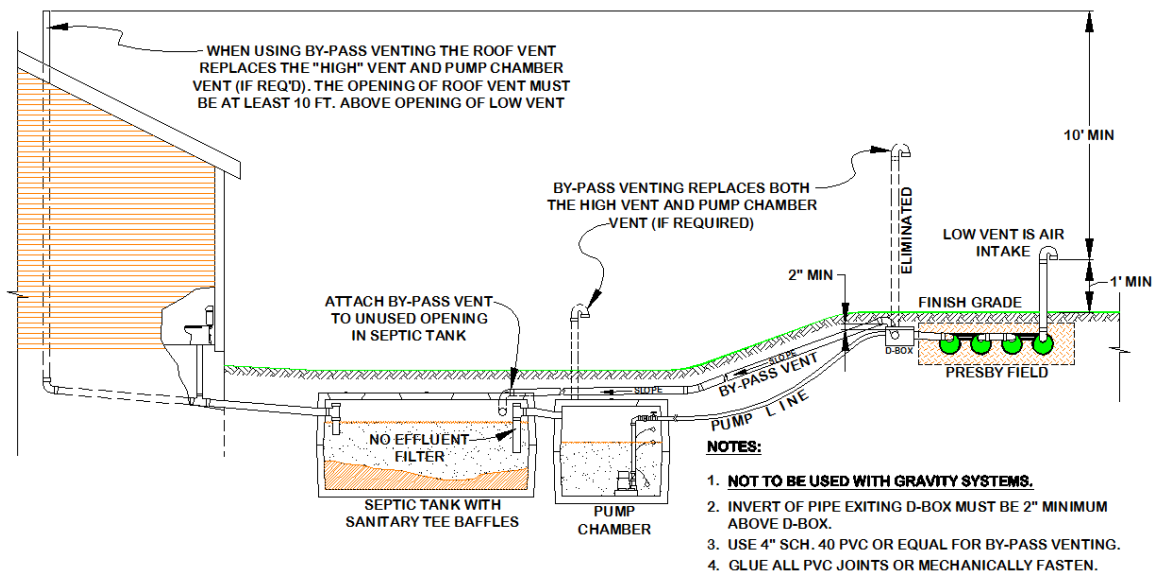

## 3.0 INSTALLATION

### 3.1 Installation Requirements

#### Component Handling

- Keep mud, grease, oil, etc. away from all components. Avoid dragging pipe through wet or muddy areas. Store pipe on high and dry areas to prevent surface water and soil from entering the pipes or contaminating the fabric prior to installation.
- The outer fabric of the AES pipe is ultra-violet stabilized; however, this protection breaks down after a period of time in direct sunlight. To prevent damage to the fabric, cover the pipe with an opaque tarp if stored outdoors.

#### Site Preparation Prior to Excavation

1. Locate and stake out the system sand bed, extension areas and soil material cover extensions on the site according to the approved plan.
2. Install sediment/erosion control barriers prior to beginning excavation to protect the system from surface water flows during construction.
3. Do not stockpile materials or equipment within the portion of the site receiving system sand.

#### Critical Reminder to Prevent Soil Compaction

It is critical to keep excavators, backhoes, and other equipment off the excavated or tilled surface of a bed. Before installing the system sand, excavation equipment should be operated around the bed perimeter; not on the bed itself. It is especially important to avoid using construction equipment down slope of the system to prevent soil compaction.

#### When to Excavate

- Do not work wet or frozen soils. If a fragment of soil from about 9 in below the surface can easily be rolled into a wire, the soil moisture content is too high for construction.
- Do not excavate the system area immediately after, during or before precipitation.

#### Tree Stumps

Before tilling, remove all grass, leaves, sticks, brush and other organic matter or debris from the excavated system site. Remove all tree stumps and the central root system below grade by using a backhoe or excavator with a mechanical "thumb" or similar extrication equipment, lifting or leveraging stump in a manner that minimizes soil disturbance. It is not necessary for the soil of the system site to be smooth when the site is prepared.

- Avoid soil disturbance, relocation, or compaction.
- Avoid mechanical leveling or tamping of dislodged soil.
- Fill all voids created by stump or root removal with system sand.

#### Raking and Tilling Procedures

All areas receiving system sand, sand fill and fill extensions shall be raked or tilled. If a backhoe/excavator is used to till the site, fit it with chisel teeth and till the site. The backhoe/excavator shall remain outside of the proposed system sand area and extensions.

- For in-ground bed systems, excavate the system bed as necessary below original grade. Using an excavator or backhoe, tilt the bucket teeth perpendicular to the bed and use the teeth to rake furrows 2 – 6 in deep into the bottom of the entire area receiving system sand or sand fill.
- For elevated bed systems remove the "A" horizon, then use an excavator or backhoe to rake furrows 2 – 6 in deep into the receiving area.

#### Install System Sand and/or Sand Fill Immediately After Excavation

- To protect the tilled area from damage by precipitation, system sand should be installed immediately after tilling.
- Work off either end or the uphill side of the system to avoid compacting soil.
- Keep at least 6 in of sand between the vehicle tracks and the tilled soil of the site if equipment must work on receiving soil.

### 3.0 INSTALLATION

- Track construction equipment should not travel over the installed system area until at least 12 in of cover material is placed over the AES pipes.
- Heavy equipment with tires shall never enter the receiving area due to likely wheel compaction of underlying soil structures.

#### Distribution Box Installation

To prevent movement, D-box shall be set on a layer of compacted soil, sand, pea gravel base or a concrete footing.

#### Level Row Tolerances

Use a laser level or transit to install rows level. Variations beyond 1 in ( $\pm 1/2$ " ) may affect system performance and are not acceptable.

#### Correct Alignment of AES Bio-Accelerator® Fabric

The Bio-Accelerator (white geo-textile fabric) is to be positioned centered along the bottom of the pipe rows (sewn seam up).

#### Row Spacers

System sand may be used to keep pipe in place while covering, but simple tools may also be constructed for this purpose. Two examples are shown. One is made from rebar, the other from wood. **Caution:** Remove all tools used as row spacers before final covering.

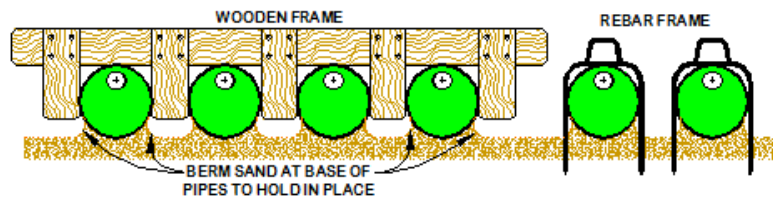

#### Connect Rows Using Raised Connections

Raised connections consist of offset adapters, 4 in PVC sewer and drainpipe, and 90° elbows. They enable greater liquid storage capacity and increase the bacterial surfaces being developed. Use raised connections to connect the rows of basic serial and combination serial configurations. Raised connections extend 2 in to 4 in into pipe and are installed on an angle (as shown in the drawing to the right). All PVC joints should be glued or mechanically fastened.

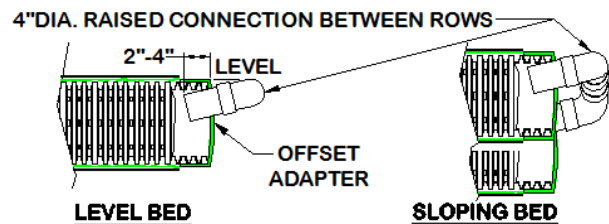

#### Raised Straight Connection

A raised straight connection is a PVC Sewer & Drain pipe configuration which is used to connect AES rows that are placed end to end along the same contour. Raised straight connections extend 2 in to 4 in into pipe and are installed on an angle (as shown in the drawings to the right). All PVC joints should be glued or mechanically fastened.

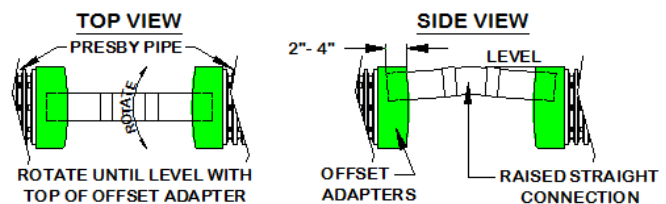

#### Backfilling Rows

1. Spread system sand between the rows.
2. Confirm pipe rows are positioned with Bio-Accelerator along the bottom (sewn seam up).
3. Straddle each row of pipe and walk heel-to-toe its entire length, ensuring that system sand fills all void spaces beneath the AES pipe.
4. Finish spreading system sand to the top of the rows and leave them exposed for inspection purposes.

## 3.0 INSTALLATION

### Backfilling and Final Grading

1. Spread system sand to a minimum of 3 in over the pipe and a minimum of 6 in on all four sides of the bed beyond the AES pipes.
2. Spread a minimum of 4 in of suitable earth cover (topsoil or loam) with a texture similar to the soil at the site and capable of sustaining plant growth above the installed system.
3. To prevent erosion, soil cover above the system shall be planted with native, shallow-rooted vegetation such as grass, wildflowers and certain perennials or ground covers.

### Fill Extensions Requirements

If any portion of the bed extends above the original grade, the fill covering the field cannot begin the required side slope taper for a distance of 6 in minimum from the outmost edge of any AES pipe.

## 4.0 REJUVENATION AND EXPANSION

### 4.1 *Bacteria Rejuvenation and Expansion*

#### **Why Would System Bacteria Rejuvenation Be Needed?**

Bacteria rejuvenation is the return of bacteria to an aerobic state. Flooding, improper venting, alteration or improper depth of soil material cover, use of incorrect sand, sudden use changes, introduction of chemicals or medicines, and a variety of other conditions can contribute to converting bacteria in any system from an aerobic to an anaerobic state. This conversion severely limits the bacteria's ability to effectively treat effluent, as well as limiting liquids from passing through. A unique feature of the AES system is its ability to be rejuvenated in place.

#### **How to Rejuvenate System Bacteria**

System bacteria are "rejuvenated" when they return to an aerobic state. By using the following procedure, this can be accomplished in most AES systems without costly removal and replacement.

1. Contact PEI before attempting rejuvenation for technical assistance.
2. Determine and rectify the problem(s) causing the bacteria conversion.
3. Drain the system by excavating at least one end of all the rows and removing the offset adapters.
4. If foreign matter has entered the system, flush the pipes.
5. Safeguard the open excavation.
6. Guarantee a passage of air through the system.
7. Allow all rows to dry for 72 hours minimum. The system sand should return to its natural color.
8. Re-assemble the system to its original design configuration. As long as there is no physical damage to the AES components, the original components may be reused.

#### **System Expansion**

AES systems are easily expanded by adding equal lengths of pipe to each row of the original design or by adding additional equal sections. All system expansions shall comply with state and local regulations. Permits may be required prior to system expansion.

#### **Reusable Components**

AES pipe and components are not biodegradable and may be reused. In cases of improper installation, it may be possible to excavate, clean, and reinstall all system components.

#### **Replacement System**

In the event of system malfunction, contact PEI for technical assistance prior to attempting rejuvenation procedures. In the unlikely event that an AES system needs to be replaced ...

- It can be reinstalled in the same location, eliminating the need for a replacement field reserve area.
- All unsuitable material shall be removed prior to replacement system construction.
- Disposal of hazardous materials to be in accordance with state and local requirements.
- Permits may be required for system replacement; contact the appropriate local or state agency.

## 5.0 OPERATION AND MAINTENANCE

### 5.1 Operation and Maintenance

#### Proper Use

AES systems do not require a maintenance and monitoring agreement, however they do require minimal maintenance as is standard for conventional onsite systems, provided the system is not subjected to abuse. An awareness of proper use and routine maintenance will guarantee system longevity. We encourage all system owners and service providers to obtain and review a copy of our Owner's Manual, available from our website [www.presbyeco.com](http://www.presbyeco.com) or via mail upon request to (800) 473-5298 or [info@presbyeco.com](mailto:info@presbyeco.com).

#### System Abuse Conditions

The following conditions constitute system abuse:

- Liquid in high volume (excessive number of occupants and use of water in a short period of time, leaking fixtures, whirlpool tubs, hot tubs, water softening equipment or additional water discharging fixtures if not specified in system design).
- Solids in high volume (excessive number of occupants, paper products, personal hygiene products, garbage disposals or water softening equipment if not specified in system design)
- Antibiotics and medicines in high concentrations
- Cleaning products in high concentrations
- Fertilizers or other caustic chemicals in any amount
- Petroleum products in any amount
- Latex and oil paints
- System suffocation (compacted soils, barrier materials, etc.) without proper venting

Note: PEI does not recommend the use of septic system additives.

#### System Maintenance/Pumping of the Septic Tank

- Inspect the septic tank at least once every two years under normal usage.
- Pump the tank when surface scum and bottom sludge occupy one-fourth or more of the liquid depth of the tank.
- If a garbage disposal is used, the septic tank will likely require more frequent pumping.
- After pumping, inspect the septic tank for integrity to ensure that no groundwater is entering it. Also check the integrity of the tank inlet and outlet baffles and repair if needed.
- Inspect the system to ensure that vents are in place and free of obstructions.
- Effluent filters require ongoing maintenance due to their tendency to clog and cut off oxygen to the system. Follow filter manufacturer's maintenance instructions and inspect filters frequently.

#### Site Maintenance

It is important that the system site remain free of shrubs, trees, and other woody vegetation, including the entire SSBA, and areas impacted by side slope tapering and perimeter drains (if used). Roots can infiltrate and cause damage or clogging of system components. If a perimeter drain is used, it is important to make sure that the outfall pipes are screened to prevent animal activity. Also check outfall pipes regularly to ensure that they are not obstructed in any way.