

# The Presby Wastewater Treatment System

## Wyoming Design and Installation Manual

### for Advanced Enviro-Septic® Wastewater Treatment Systems



- ✓ Minimizes the Expense
- ✓ Protects the Environment
- ✓ Preserves the Site

#### AES System in Wyoming

1.0 INTRODUCTION	3
1.1 Background	3
1.2 System Components	4
2.0 SYSTEM DESIGN	5
2.1 Sizing	5
2.2 Design Procedure	6
2.3 Design Examples	6
2.4 Design Specifications	9
2.5 System Configurations	12
2.6 Pump Systems	15
2.7 Venting	16
2.8 Site Selection	19
3.0 INSTALLATION	20
4.0 REJUVENATION AND EXPANSION	23
5.0 OPERATION AND MAINTENANCE	24
6.0 WARRANTY	25



## Presby Environmental, Inc.

An Infiltrator Water Technologies Company  
*The Next Generation of Wastewater Treatment Technology*

143 Airport Road, Whitefield NH 03598

Tel: 800-473-5298 Fax: 603-837-9864

info@presbyeco.com

www.PresbyEnvironmental.com

The information in this Manual is subject to change without notice. We recommend that you check your state's page on our website on a regular basis for updated information. Your suggestions and comments are welcome. Please contact us at:

Presby Environmental, Inc.  
143 Airport Road  
Whitefield, NH 03598  
Phone: 1-800-473-5298 Fax: (603) 837-9864  
Website: [www.presbyenvironmental.com](http://www.presbyenvironmental.com)

The products and methods depicted in this Manual are protected by one or more patents.

Advanced Enviro-Septic® is a registered trademark of Presby Environmental Inc.

**IMPORTANT NOTICE:** This Manual is intended ONLY for use in designing and installing Presby Environmental's Advanced Enviro-Septic® Wastewater Treatment Systems. The processes and design criteria contained herein are based solely on our experience with and testing of Advanced Enviro-Septic®. Substitution of any product is prohibited.

© Presby Environmental, Inc. October 2020  
All Rights Reserved

## 1.0 INTRODUCTION

### 1.1 Background

The Advanced Enviro-Septic® (AES) Wastewater Treatment System utilizes a unique combination of components that work together to treat effluent and prevent suspended solids from sealing the underlying soil. Comprised of a patented corrugated, perforated plastic pipe with interior skimmer tabs and cooling ridges, the large-diameter pipe retains solids while the Bio-Accelerator® fabric, coarse fibers, and geo-textile fabric provide multiple bacterial surfaces to treat effluent prior to its contact with the receiving soils. The continual cycling of effluent (the rising and falling of liquid inside the pipe) enhances bacterial growth. The AES system is completely passive, and yet provides increased aeration and a greater bacterial treatment area than traditional systems. The result is a system that is more efficient, lasts longer, and has a virtually no negative environmental impact.

The AES system has been successfully tested and certified to NSF/ANSI 40, Class I (a certification typically given to mechanical aeration devices) and BNQ Class I, II, III standards.

Additional system benefits include:

- requires a smaller area
- installs easily and quickly
- eliminates the need for environmentally impactful washed stone
- adapts easily to residential, commercial and difficult sites
- prevents formation of organic material at the receiving soil interface
- blends “septic mounds” into sloping terrain
- safely recharges groundwater

#### Environmental Standards and Technical Support

All AES systems shall be designed and installed in compliance with the procedures and specifications detailed in this Manual and in the product’s state approval. Waivers may be utilized for alternative designs. In the event of contradictions between this Manual and state rules, PEI should be contacted for technical assistance at (800) 473-5298.

PEI provides technical support free of charge to all individuals using our products or involved in the permitting process. For any questions about our products or the information contained in this Manual, please contact us at (800) 473-5298, send an email to [info@presbyeco.com](mailto:info@presbyeco.com). The technical support staff at PEI is committed to providing comprehensive product information and support at no cost to our customers. The assistance we are able to provide in this way is based on limited information and therefore should be considered general in nature. Accordingly, PEI disclaims any liability whatsoever in connection with providing technical support.

#### Certification Requirements

Designers and installers who have not previously attended a PEI certification course are required to obtain certification. Certification is obtained by attending a certification course presented by PEI or its sanctioned representative or by viewing tutorial videos on our website and then successfully passing a short assessment test. PEI recommends professionals involved in the inspection or review of AES systems also become PEI certified.

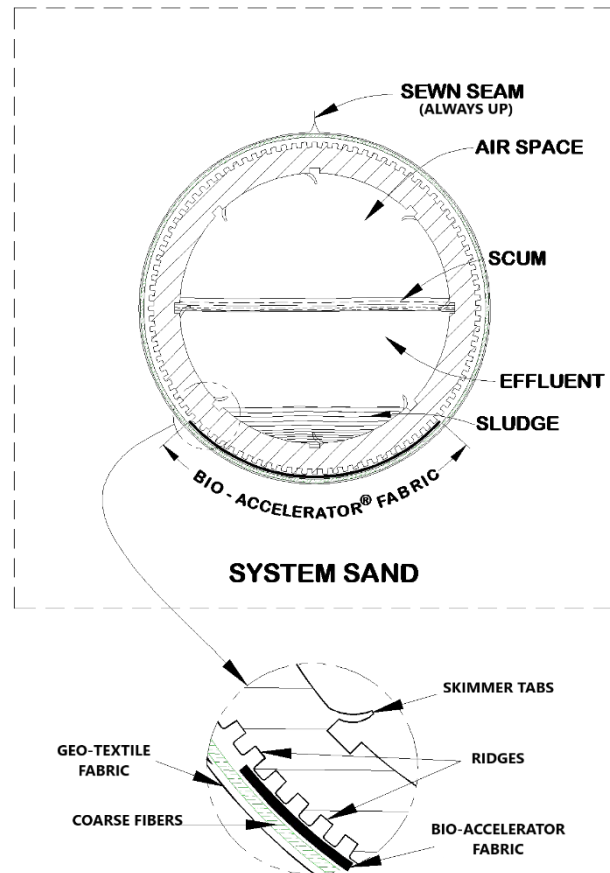

## 1.0 INTRODUCTION

### 1.2 System Components

#### AES Pipe

- nominal exterior diameter of 12 in
- holding capacity of 5.8 gallons per foot
- 10 ft length of AES pipe is flexible enough to bend up to 90° and can be cut to any length
- made with a significant amount recycled material



**Offset Adapter** - A 12 in plastic fitting with a single inlet hole oriented in the 12 o'clock position and designed to accept a 4 in sewer line, raised connection or vent pipe.

**Double Offset Adapter** - A 12 in plastic fitting with two 4 in holes designed to accept a 4 in inlet pipe, raised connection, vent or vent manifold, and/or bottom drain, depending upon the requirements of the design configuration.

**Coupling** - A plastic fitting used to create a connection between two pieces of AES pipe.

**System Sand** - The system sand that surrounds the AES pipes is an essential component of the system. It is critical that the correct type and amount of system sand is used during construction. System sand shall be coarse to very coarse, clean, granular sand, free of organic matter. System sand is placed a minimum of 3 in above and 6 in below, between, and around the outer perimeter of the AES pipes. It shall adhere to all of the following percentage and quality restrictions:

**System Sand Specification**

Sieve Size	Percent Retained on Sieve (by weight)
3/4 in (19 mm)	0
#10 (2 mm)	0 - 35
#35 (0.50 mm)	40 - 90
Note: not more than 3% allowed to pass the #200 sieve (verified by washing sample per requirements of ASTM C-117)	

#### System Sand Bed Height Dimension

The height of an AES sand bed measures 21 in minimum (not including cover material):

- minimum of 6 in of system sand below the AES pipe;
- 12 in diameter of the pipe; and
- minimum of 3 in of system sand above the AES pipe.

**System Sand Acceptable Alternative** - ASTM C-33 (concrete sand), natural or manufactured sand, with not more than 3% passing the #200 sieve (verified by washing the sample per the requirements of ASTM C-117 as noted in the ASTM C-33 specification) may be used as an acceptable alternate material for use as system sand.

**Sand Fill** - Sand fill may be used to raise the elevation of the system in order to meet the required separation distance from the SHWT or restrictive feature or in side-slope tapers. No organic material or stones larger than 6 in are allowed in the sand fill. System sand may be used in place of sand fill.

## 2.0 SYSTEM DESIGN

### 2.1 Sizing

**Table A: AES Pipe Requirements**

System Type	AES Pipe Loading Rate
Residential System	70 ft/br
Commercial (Non-Residential) System	2.14 gpd/ft

Assumes residential strength effluent. Contact Presby Environmental for technical assistance with high strength wastewater.

**Table B: Daily Design Flows**

No. of Bedrooms	Gallons per day
1	150
2	280
3	390
4	470
5	550
6	630

An unfinished basement is considered two (2) additional bedrooms.

The design flow shall be increased by eighty (80) gpd for each additional bedroom over six (6).

Non-residential wastewater design flow rates are calculated according to Chapter 25, Section 5, Table 2.

**Table C: System Sand Bed Area Required**

Percolation Rate Minutes per Inch mpi	Loading Rate (LR) Gallons/Day/sq ft gpd/ft <sup>2</sup>	Percolation Rate Minutes per Inch mpi	Loading Rate (LR) Gallons/Day/sq ft gpd/ft <sup>2</sup>
5	1.60	21	0.90
6	1.50	22	0.88
7	1.42	23 - 24	0.86
8	1.36	25	0.84
9	1.30	26 - 27	0.82
10	1.24	28 - 29	0.80
11	1.20	30 - 31	0.78
12	1.16	32 - 33	0.76
13	1.12	34 - 35	0.74
14	1.08	36 - 37	0.72
15	1.04	38 - 40	0.70
16	1.00	41 - 43	0.68
17	0.98	44 - 46	0.66
18	0.96	47 - 50	0.64
19	0.94	51 - 55	0.62
20	0.92	56 - 60	0.60

**Table D: System Limitations**

Percolation Rate Minutes per Inch (mpi)	% System Slope Maximum	% Site Slope Maximum
15 or less	25	25
16-30	20	25
31-60	15	20

### 2.2 Design Procedure

**Step #1: Calculate the Minimum Amount of AES Pipe Needed**

From Table A: Calculate the minimum amount of AES pipe needed: use 70 ft/br for residential systems or 2.14 gpd/ft for commercial/non-residential systems treating residential strength effluent – contact Technical Support for high strength wastewater.

## 2.0 SYSTEM DESIGN

### **Step #2: Determine System Sand Bed Area Required (SSBA)**

From Table C: using the soil's percolation rate and associated loading rate (LR), calculate the minimum SSBA required by dividing the daily design flow (gpd) from Table B by the loading rate. For daily design flows exceeding 2,000 gpd, an Underground Injection Control permit is required by the DEQ.

### **Step #3: Choose Allowable System Slope**

From Table D: choose an allowable system slope using the soil's percolation rate.

### **Step #4: Calculate the Number of Serial Sections Needed**

Calculate the minimum number of serial sections required (does not apply to parallel configuration): divide the daily design flow by 750 gpd (round up to nearest whole number).

### **Step #5: Determine Row Length and Quantity Needed**

Select a row length suitable for the site and calculate the number of rows (round up to a whole number). The number of rows must be evenly divisible by the number of serial sections required (add rows as necessary – does not apply to parallel layouts).

### **Step #6: Determine Pipe Layout Width (PLW)**

Calculate the PLW (the distance of the width of the pipes from outside edge to outside edge) using a 1.5 ft minimum center-to-center row spacing (larger spacing allowed).  $PLW = [(# \text{ of rows} - 1) \times \text{spacing (1.5 ft)}] + 1 \text{ ft}$ .

### **Step #7: Determine Minimum System Sand Bed Width (SSBW)**

Calculate the minimum SSBW by dividing the SSBA from Step #2 by the selected row length from Step #5 + 1 ft (allows 6 inches of sand beyond the ends of the rows).

### **Step #8: Verify Final Bed Width Requirements**

Verify the minimum SSBW from Step #7 will cover all the rows in the bed:

- a) Level beds and beds sloping less than 5%: If the minimum SSBW is less than the (PLW + 1 ft), use (PLW + 1 ft) as the new minimum SSBW.
- b) Beds sloping > 5%: If the minimum SSBW is less than the (PLW + 3.5 ft), use (PLW + 3.5 ft) as the new minimum SSBW. Adding 3.5 ft to the pipe layout width accounts for a 2.5 ft system sand extension on the down slope side of the field.

### **Step #9: Calculate System Sand Extensions (SSEs):**

- a) Level beds: SSE are placed on each side of AES pipes =  $[SSBW - (PLW + 1)] \div 2$ . There will be no SSE's if the SSBW = (PLW + 1 ft).
- b) Sloping Beds: SSE placed entirely on the down slope side of the bed =  $SSBW - (PLW + 1)$  and must be at least 2.5 ft (3 ft from the edge of the AES pipe) for beds sloping greater than 5%.

## 2.3 Design Examples

**Design Example #1** Design a four-bedroom residential AES system in soils with a perc rate of 10 mpi, with a site slope of 3% and system slope of 0% (level bed):

### **Step #1: Calculate the Minimum Amount of AES Pipe Needed**

AES pipe required: 4 bedrooms at 70 ft per bedroom = 280 ft.

### **Step #2: Determine System Sand Bed Area Required (SSBA)**

SSBA: 470 gpd (from Table B)  $\div$  1.25 gpd/ft<sup>2</sup> LR (from Table C) = 376 ft<sup>2</sup>.

### **Step #3: Choose Allowable System Slope**

Site slopes 3%, no need to slope this system.

### **Step #4: Calculate the Number of Serial Sections Needed**

Serial sections required = 470 gpd  $\div$  750 gpd/section = .63 (round up to 1). The system can be installed using basic serial distribution.

## 2.0 SYSTEM DESIGN

- Step #5: *Determine Row Length and Quantity Needed*  
Using a row length of 70 ft requires four rows ( $280 \text{ ft} \div 70 \text{ ft} = 4 \text{ rows}$ ).
- Step #6: *Determine Pipe Layout Width (PLW)*  
Calculate the PLW using a 1.5 ft minimum center-to-center row spacing (larger spacing allowed).  $PLW = [(4 \text{ rows} - 1) \times \text{spacing} (1.5 \text{ ft})] + 1 \text{ ft} = 5.5 \text{ ft}$ .
- Step #7: *Determine Minimum System Sand Bed Width (SSBW)*  
Minimum SSBW =  $376 \text{ ft}^2 \div (70 \text{ ft} + 1 \text{ ft}) = 5.3 \text{ ft}$  (round up to 5.5 ft for ease of construction).
- Step #8: *Verify Final Bed Width Requirements*  
a) 5.5 ft SSBW is less than 6.5 ft (5.5 ft PLW + 1 ft), new SSBW = 6.5 ft.  
b) not required.
- Step #9: *Calculate System Sand Extensions (SSEs):*  
a) System sand extensions =  $[6.5 \text{ ft SSBW} - (5.5 \text{ ft PLW} + 1 \text{ ft})] \div 2 = 0$ , No system sand extensions are needed.  
b) Not required.

Illustration of Example #1, Basic Serial Distribution:

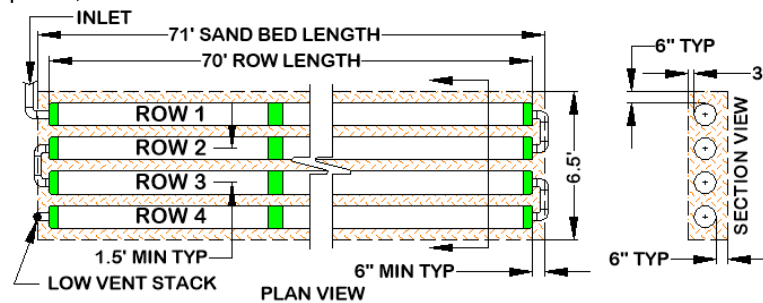

**Design Example #2** Design a five-bedroom residential AES system in soils with a perc rate of 31 mpi, with a site slope of 12% as an elevated bed)

- Step #1: *Calculate the Minimum Amount of AES Pipe Needed*  
AES pipe required: 5 bedrooms at 70 ft per bedroom = 350 ft.
- Step #2: *Determine System Sand Bed Area Required (SSBA)*  
SSBA:  $550 \text{ gpd} \div 0.77 \text{ gpd/ft}^2 \text{ LR from Table A} = 714.29$  (round up to 715 ft<sup>2</sup>).
- Step #3: *Choose Allowable System Slope*  
Site slopes 12%, per table C the system is allowed to slope up to 15% and the site can slope up to 20% for the perc rate of this site. The system will be designed to slope with the site at 12%.
- Step #4: *Calculate the Number of Serial Sections Needed*  
Serial sections required =  $550 \text{ gpd} \div 750 \text{ gpd/section} = .73$  (round up to 1). The system can be installed using basic serial distribution.
- Step #5: *Determine Row Length and Quantity Needed*  
Using a row length of 70 ft requires five rows ( $350 \text{ ft} \div 70 \text{ ft} = 5 \text{ rows}$ ).
- Step #6: *Determine Pipe Layout Width (PLW)*  
Calculate the PLW using a 1.5 ft minimum center-to-center row spacing (larger spacing allowed).  $PLW = [(5 \text{ rows} - 1) \times \text{spacing} (1.5 \text{ ft})] + 1 \text{ ft} = 7.0 \text{ ft}$ .
- Step #7: *Determine Minimum System Sand Bed Width (SSBW)*  
Minimum SSBW =  $715 \text{ ft}^2 \div (70 \text{ ft} + 1 \text{ ft}) = 10.07 \text{ ft}$ . (round up to 10.5 ft for ease of construction).

## 2.0 SYSTEM DESIGN

Step #8: *Verify Final Bed Width Requirements*

- a) Bed is a sloping bed, go to b).
- b) Beds sloping > 5%: Minimum SSBW 10.5 is equal to (PLW (7.0) + 3.5 ft). Adding 3.5 ft to the pipe layout width accounts for a 2.5 ft SSE on the down slope side of the field.

Step #9: *Calculate System Sand Extensions (SSEs):*

- a) Bed is a sloping bed, go to b).
- b) Sloping Beds: SSE placed entirely on the down slope side of the bed =  $10.5 - (7 + 1) = 2.5$  SSE. This is equal to the 2.5 ft (3 ft from the edge of the AES pipe) SSE requirement for beds sloping greater than 5%.

Illustration of Example #2, Basic Serial Distribution:

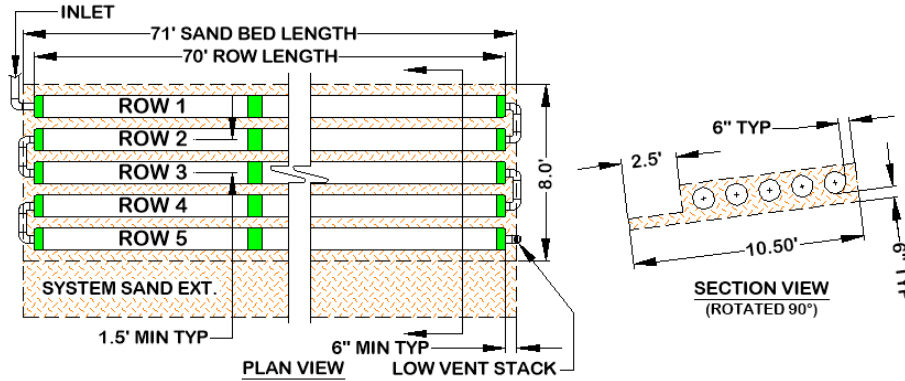

**Design Example #3** Design a mixed-use system for a two-bedroom apartment plus 471 GPD commercial use with normal strength wastewater, in soils with a perc rate of 10 mpi, with a site slope of 2% and system slope of 0% (level bed):

Step #1: *Calculate the Minimum Amount of AES Pipe Needed*

- AES pipe required for apartment: 2 bedrooms at 70 ft per bedroom = 140 ft;  
 AES pipe required for offices: 471 GPD ÷ 2.14 = 221 ft;  
 Total AES pipe required = 361 ft

Step #2: *Determine System Sand Bed Area Required (SSBA)*

- SSBA: [280 GPD (apartment) + 471 GPD (commercial)] ÷ 1.25 gpd/ft<sup>2</sup> LR from Table A = 601 ft<sup>2</sup>.

Step #3: *Choose Allowable System Slope*

- Site slopes 2%, system slope 0% (level).

Step #4: *Calculate the Number of Serial Sections Needed*

- Serial sections required = 751 gpd ÷ 750 gpd/section = 1.01 (round up to 2). Use a combination distribution layout (parallel layout could also be used).

Step #5: *Determine Row Length and Quantity Needed*

- Using a row length of 62.5 ft requires six rows (361 ft ÷ 62.5 ft = 6 rows).

Step #6: *Determine Pipe Layout Width (PLW)*

- Calculate the PLW using a 1.5 ft minimum center-to-center row spacing (larger spacing allowed). PLW = [(6 rows - 1) x spacing (1.5 ft)] + 1 ft = 8.5 ft.

Step #7: *Determine Minimum System Sand Bed Width (SSBW)*

- Minimum SSBW = 601 ft<sup>2</sup> ÷ (62.5 ft + 1 ft) = 9.47 ft. (round up to 9.5 ft for ease of construction).

Step #8: *Verify Final Bed Width Requirements*

- a) 9.5 ft SSBW is equal to 9.5 ft (8.5 ft PLW + 1 ft) SSBW needed to cover all the rows. No adjustment to



## 2.0 SYSTEM DESIGN

- the SSBW is required.
- b) Not required.

Step #9: Calculate System Sand Extensions (SSEs):

- a) System sand extensions =  $[9.5 \text{ ft SSBW} - (8.5 \text{ ft PLW} + 1 \text{ ft})] \div 2 = 0$ , No system sand extensions are needed.
- b) Not required.

Illustration of Example #3, Combination Distribution Layout:

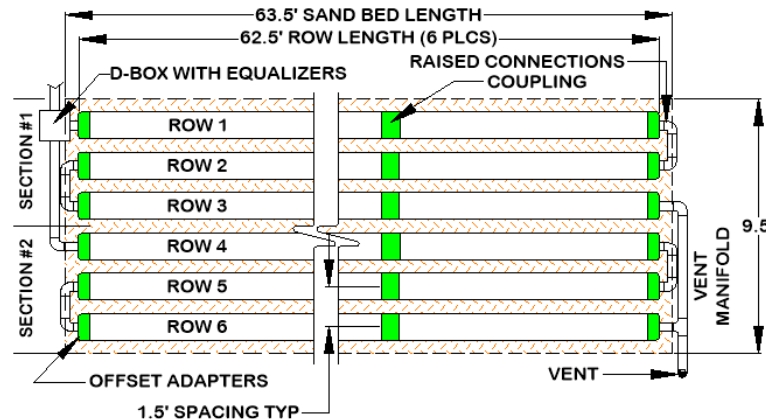

## 2.4 Design Specifications

The AES system shall be designed in accordance with this Manual and state rules and can be installed using either bed or trench design utilizing any of the design configurations outlined in this Manual.

### Daily Design Flow

Residential daily design flow for AES systems is calculated in accordance with state rules. Systems servicing more than two residences shall use the commercial specifications detailed in the sizing tables. The minimum daily design flow shall be one bedroom for any single-family residential system and 300 gpd for any commercial system.

### Septic Tank

The AES system is designed to treat effluent that has received “primary treatment” in a standard septic tank. Septic tanks shall be sized according to state/local rules.

### Water Purification Systems

- Water purification systems and water softeners should not discharge into any AES system.
- If there is no alternative means of disposing of this backwash other than in the system, the system will need to be “oversized.” Calculate the total amount of backwash in gpd, multiply by 2, and add this amount to the daily design flow when determining the field and septic tank sizing.
- Water purification systems and water softeners require regular routine maintenance; consult and follow the manufacturer’s maintenance recommendations.

### Pressure Distribution

The use of pressure distribution lines in AES systems is prohibited. Pumps may be utilized when necessary only to gain elevation and to feed a distribution box which then distributes effluent by gravity to the AES field. Siphon dosing is permitted; adequate venting is required in a siphon-dosed system or pumped system, which may require an additional high vent (referred to as “differential venting”).

## 2.0 SYSTEM DESIGN

### Effluent (Wastewater) Strength

The AES pipe requirement for bed or trench systems is based on residential strength effluent, which has received primary treatment in a septic tank. Designing a system that will treat higher strength wastes requires additional AES pipe. In these situations, our Technical Advisors shall be consulted for recommendations at (800) 473-5298.

### Effluent Filters

- Effluent filters are not required in Wyoming and are not recommended for use with AES systems.
- If used, effluent filters shall be maintained on at least an annual basis. Follow manufacturer's instructions regarding required inspections, cleaning and maintenance of the effluent filter.
- Effluent filters must allow the free passage of air to ensure the proper functioning of the system.
- Charcoal filters in vent stacks (for odor control) are not recommended by PEI. They can block air flow and potentially shorten system life.

### Flow Equalizers Required

All distribution boxes (D-box) used to divide effluent flow require flow equalizers in their outlets. A flow equalizer is an adjustable plastic insert installed in the outlet holes of a D-box to equalize effluent distribution to each outlet whenever flow is divided. Each bed or section of combination serial distribution is limited to a maximum of 15 gallons per minute (gpm), due to the flow constraints of the equalizers. Example: pumping to a combination system with 3 sections (using 3 D-box outlets). The maximum delivery rate is  $(3 \times 15) = 45$  gpm. Always provide a means of velocity reduction when needed. All systems with combination serial distribution or multiple bed distribution shall use flow equalizers in each D-box outlet.



### Two Inch Rule

The outlet of a septic tank or D-box shall be set at least 2 in above the highest inlet of the AES row, with the connecting pipe slope not less than 1% (approximately  $\frac{1}{8}$  in per foot). Illustration of 2 in rule:

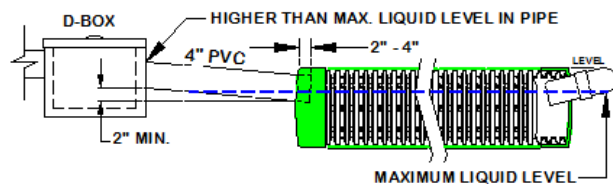

### AES Pipe Requirement

AES systems use the bed sizing tables, pipe and installation requirements noted in this Manual.

- Residential systems: 70 ft per br
- Non-Residential/Commercial systems comprised of residential strength effluent: 2.14 gpd per ft

### Row Requirements

- All beds shall have at least 2 rows.
- Maximum row length for any system is 100 ft of pipe.
  - AES systems are recommended to be designed and installed as long and narrow as practical for the site.
- Recommended minimum row length is 30 ft of pipe.
  - A combination (or D-box) distribution system shall be used if any row length is less than 30 ft.
  - A minimum of two D-box outlets must be used and the field must be vented.
- Minimum center-to-center spacing is 1.5 ft for all systems. Spacing may be increased at the discretion of the system designer or as needed to meet the required SSBA.
- Sewn seam must be oriented in the 12 o'clock position. This correctly orients the Bio-Accelerator® fabric in the 6 o'clock position.
- For level beds the AES rows shall be centered in the middle of the system sand bed area and any system sand extensions divided evenly on both sides.
- For sloping beds: the elevations for each AES row must be provided on the drawing. All rows shall be grouped 6 in from the up-slope edge of the system sand bed area (SSBA) with any system sand extensions

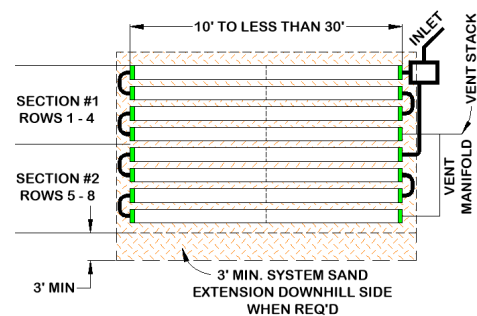

## 2.0 SYSTEM DESIGN

placed entirely on the downslope side. Systems sloping greater than 5% require a 2.5 ft system sand extension on the downslope side of the bed (3 ft when measured from the pipe).

- Each row must be laid to within  $\pm 1/2$  in (total of 1 in) of the specified elevation and preferably should be parallel to the contour of the site.
- It is most convenient if row lengths are designed in exact 10 ft increments to accommodate the length of the AES pipe as manufactured. However, AES pipe lengths can be cut to any length.

### System Sand Extensions

System sand extensions are placed on the down slope side of sloping systems and equally divided on each side of level systems. The system sand extension is measured from the tall portion of the system sand bed. In systems sloping more than 5%, a 2.5 ft minimum system sand extension is required. The system sand extension area is a minimum of 6 in deep. For multiple slope beds, if any portion of the bed has a system slope greater than 5%, a 2.5 ft minimum system sand extension is required. Illustration of bed with multiple slopes below.

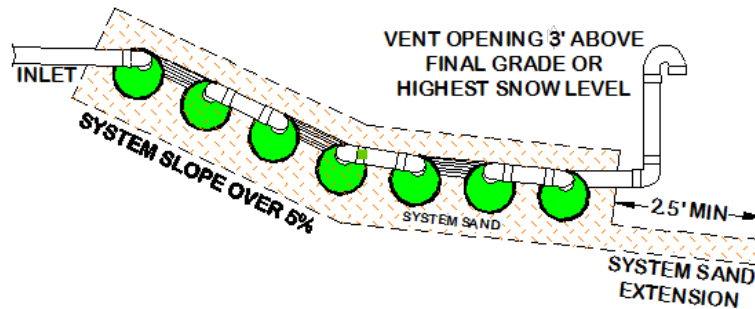

### Sloping Sites and Sloping Mound Systems

- The percentage of slope in all system drawings refers to the slope of the system, not the existing terrain ("site slope") and refers to the slope of the bed itself ("system slope").
- The system slope and the site slope do not have to be the same.
- Maximum site slope is 25% and maximum system slope is 25%; permissible slope varies depending on the soil's perc rate (see Table C, p. 8).

### Separation Distances (Horizontal and Vertical)

Horizontal separation distances are measured from the outermost edge of the system sand bed area. Vertical separation distances are measured from the system sand/receiving soil interface.

- The minimum vertical separation distance between the AES system and the Seasonal High Ground Water (SHGW) is 24 for systems where enhanced treatment is not required or 42 in for systems where enhanced treatment is required.
- Systems utilizing reduced separation distance per variance are required to have an inspection port to monitor seasonal high groundwater.

### Barrier Materials over System Sand

No barrier materials (hay, straw, tarps, etc.) are to be placed between the system sand and cover material. The only exception is the placement of the specified fabric to achieve H-20 loading requirements.

## 2.0 SYSTEM DESIGN

### 2.5 System Configurations

#### Elevated Bed Systems (Mounds)

Elevated beds are designed for sites with soil, depth to groundwater or restrictive feature constraints that do not allow for in-ground bed systems. An elevated bed system is a soil absorption field with any part of the system above original grade. Side-slope tapering is used to blend the raised portion of the system with the existing grade. Elevated bed systems require 6 in fill extensions on each side (measured from the pipe), after which side-slope tapering is to be a maximum of 3 horizontal feet for each 1 ft of vertical drop until it meets existing grade. In systems sloping greater than 5%, there must be a minimum of 2.5 ft. of system sand extension (3 ft measured from the pipe) beyond the last down-slope row of pipe. There must be a minimum of 12 in of cover material over the ends of all system sand extensions (if present).

Illustration of an elevated level bed:

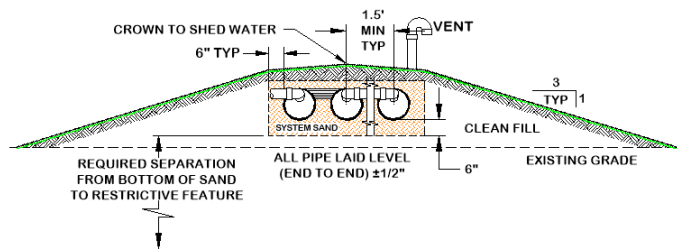
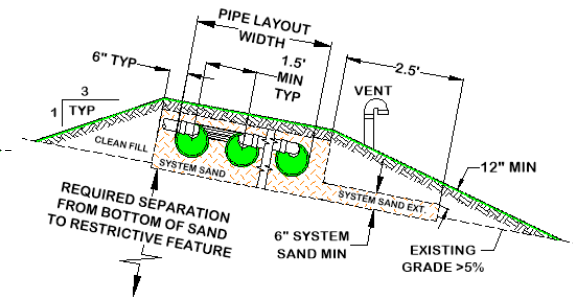

Illustration of an elevated sloping bed:



#### In-Ground Bed Systems

Systems are installed below existing grade for sites with no soil restrictive features to limit placement. In-ground systems that slope over 5% require a 2.5 ft system sand extension on the downhill side of the field.

In-ground on level site:

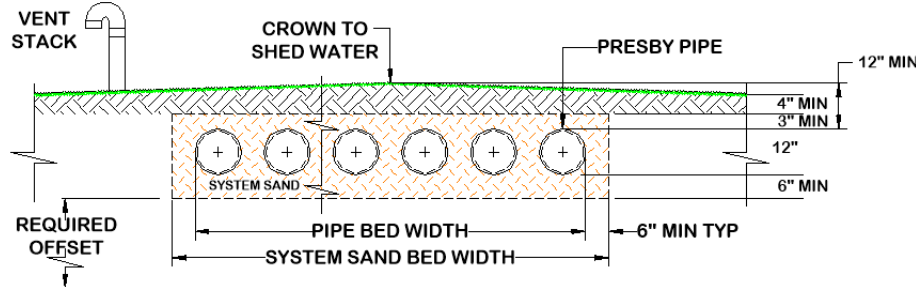

#### Trench Systems

AES pipe may be installed in trench configurations on level or sloping terrain and may utilize serial, combination, butterfly, or parallel distribution. Trench systems incorporate one or more rows of AES pipe per trench. A minimum of 3 in of system sand is required above and 6 in below, between, and around the perimeter of the AES pipe. Consult state rules for acceptable trench width and/or required trench separation.

#### Basic Serial Distribution

AES rows are connected in series at the ends with raised connections, using offset adapters.

- Used for single beds of 750 gpd or less and multiple beds where each bed receives 750 gpd or less.
- Incorporates rows in serial distribution in a single bed.
- Rows shall meet requirements outlined in the design criteria above.
- Gravity fed basic serial systems may be fed directly from the septic tank.
- Bed may be constructed with unusual shapes to avoid site obstacles or meet setback requirements.



## 2.0 SYSTEM DESIGN

Illustration of basic serial systems bed designs:

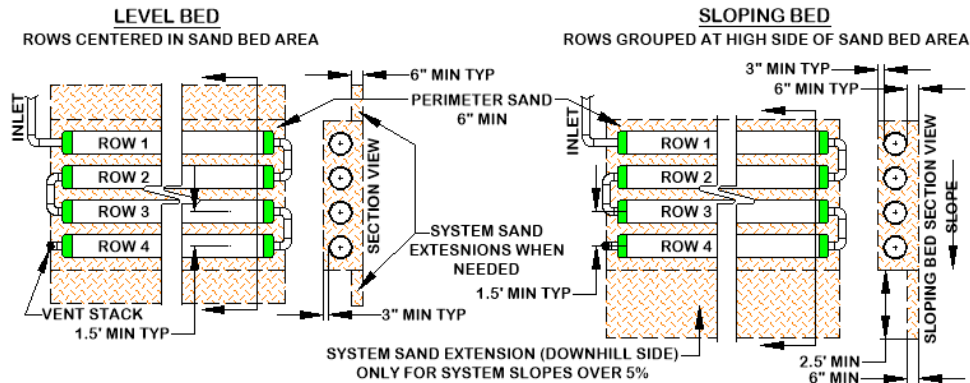

### Butterfly Configuration

- A “butterfly configuration” is considered a single bed system with two or more sections extending in opposite directions from the D-box along the contour.
- Butterfly configurations are generally used to accommodate bed lengths longer than the maximum row length of 100 ft.
- Beds can contain any number of serial sections.
- Rows shall meet requirements outlined in the design criteria above.

Illustration of a butterfly configuration bed design:

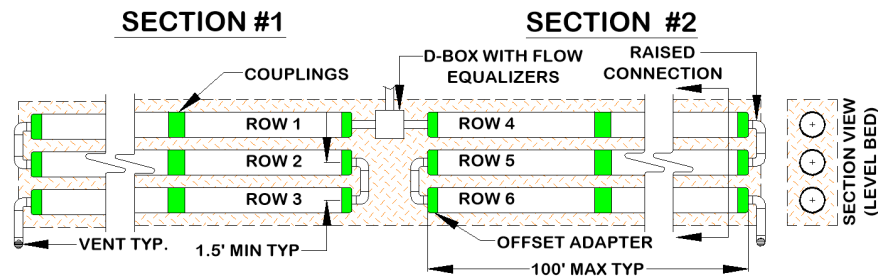

### Combination Serial Distribution

Combination serial distribution within one bed, or multiple beds, is required for systems with daily design flows greater than 750 gpd. Effluent flow is divided evenly to each section using a D-box with flow equalizers.

- Consists of two or more serial sections (with a maximum loading of 750 gpd/section) installed in a single bed each section receiving an equal amount of effluent from a D-box with flow equalizers.
- Each section consists of a series of AES rows connected at the ends with raised connections, using offset adapters and PVC sewer and drainpipe.
- There is no limit on the number of sections within a bed.
- Each section shall have the same linear feet of pipe determined by dividing the total minimum linear feet required in the system by the number of sections required.
- A section may exceed the minimum linear feet required.
- When the vent manifold is on the same side as the serial section inlets, the manifold runs over the top of these inlets.

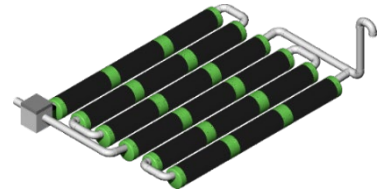

## 2.0 SYSTEM DESIGN

Rows must meet requirements outlined in the design criteria above except rows within a section may vary in length to accommodate site constraints as shown below. Illustrations of combination serial systems:

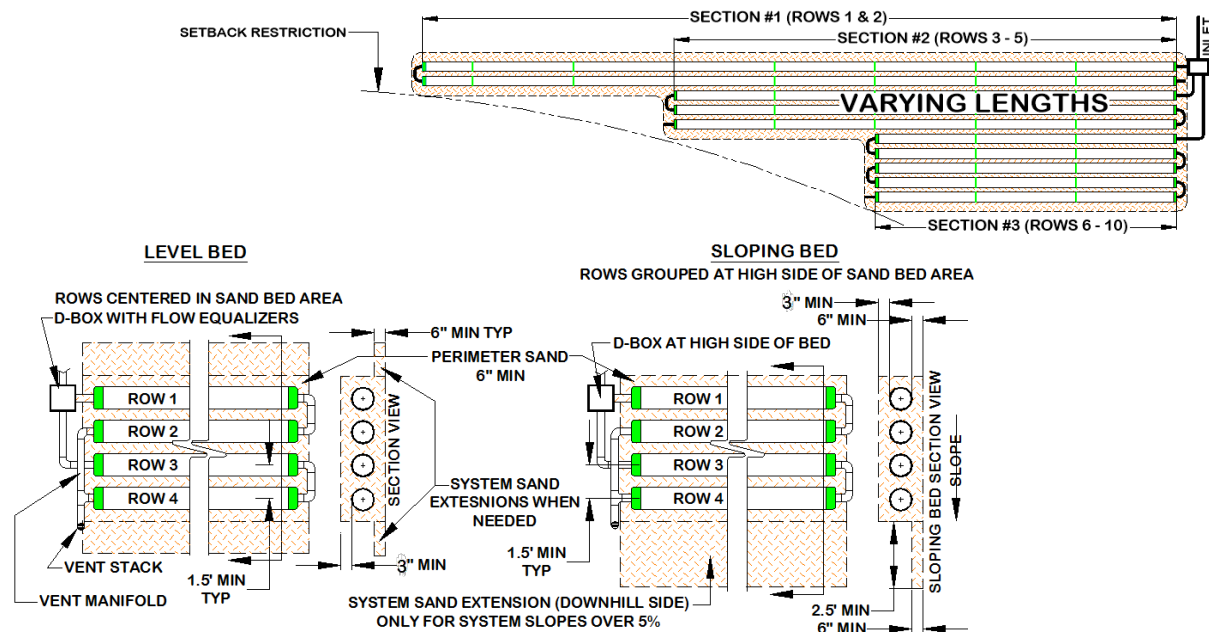

### D-box (Parallel) Distribution

- All rows in this configuration must be the same length.
- Flow equalizers must be used in the D-box.
- Use a manifold to connect the ends of all rows. Manifold shall be sloped toward AES pipes.
- D-box placement shall be installed on level, firmly compacted soil.
- All rows shall be laid level end-to-end.
- A 2 in min. drop is required between the D-box outlets and the AES pipe inlets.
- Rows shall meet requirements outlined in the design criteria above.

Illustrations for D-box (parallel) distribution bed design:

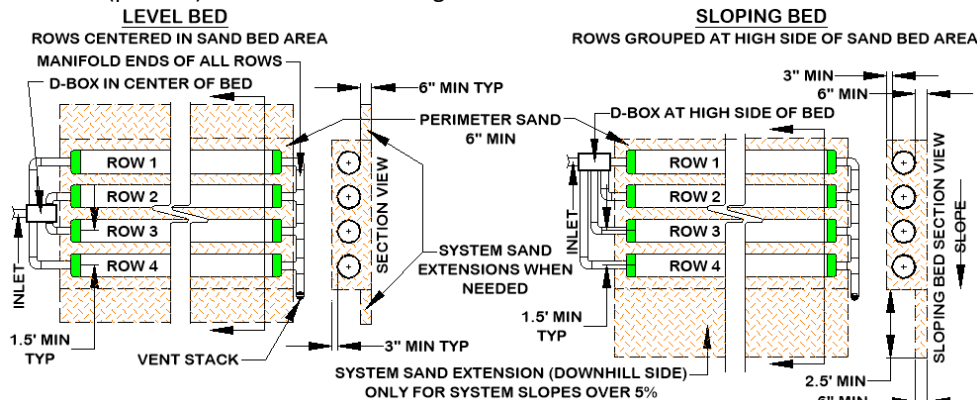

### Multiple Bed Distribution

Incorporates two or more beds, each bed receiving an equal amount of effluent from a D-box. Multiple beds may be oriented along the contour of the site or along the slope of the site.

- Each bed shall have the same minimum linear feet of pipe. The minimum linear feet of pipe per bed is determined by dividing the total linear feet required in the system by the number of beds.
- Rows within a bed may vary in length to accommodate site constraints, except with D-box configuration which requires all rows to be the same length.

## 2.0 SYSTEM DESIGN

- End-to-end configurations are preferred to side-to-side configurations.
- Bed separation distance is measured from the edge of the SSBA and is dependent on state requirements.

Illustration of End-to-End multiple beds:

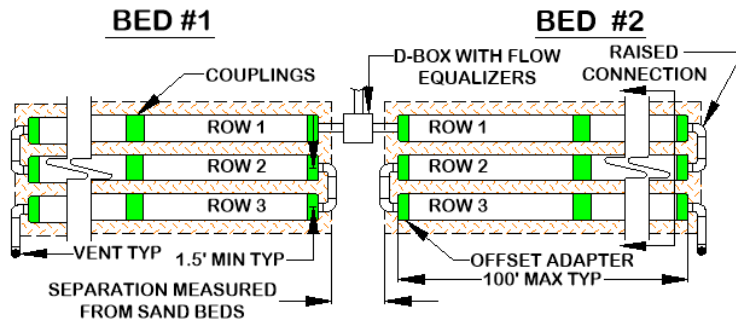
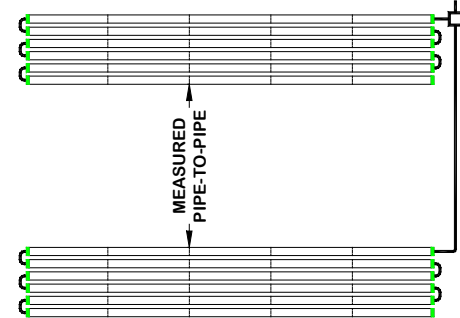

Illustration of Side-to-Side multiple beds:



### Angled and Curving Beds

Angled and curving beds are used to avoid obstacles and work well around structures, setbacks, and slopes. Multiple curves can be used within a system to accommodate various contours of the site.

- Rows are angled by bending pipes up to 90 degrees or through the use of offset adapters
- Rows shall meet requirements outlined in the design criteria above.

Illustrations of angled and curving beds:

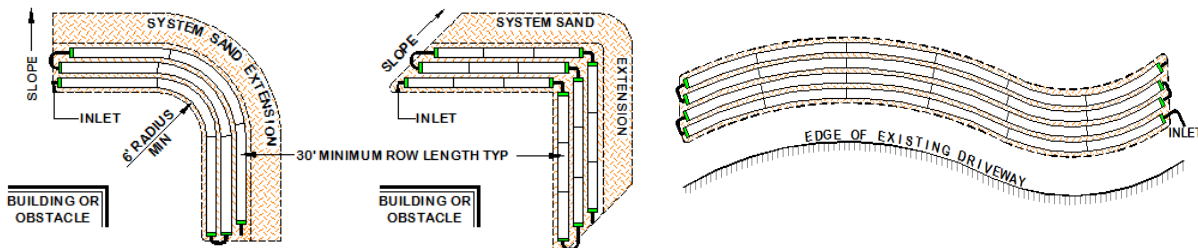

## 2.6 Pump Systems

Pumped systems supply effluent to the system using a pump and D-box when site conditions do not allow for a gravity system. Dosing siphons are also an acceptable means of delivering effluent to the system.

- Pump volume per dose shall be no greater than 1-gallon times the total linear feet of AES pipe.
- Pump dosing should be designed for a minimum of 6 cycles per day; 6-8 cycles per day are recommended.
- If possible, the dosing cycle should provide one hour of drying time between doses.
- Pump systems must have a high-water alarm float or sensor installed inside the pump chamber. Follow state, local and national code requirements.
- Pumped systems with basic serial distribution are limited to a maximum dose rate of 40 gpm and do not require the use of a flow equalizer on the D-box outlet.
- All pump systems require differential venting.
- All pumped systems require a D-box with baffles, a velocity reducing tee or other means to be used for velocity reduction.
- All systems with combination serial distribution or multiple bed distribution shall use flow equalizers in each D-box outlet with each bed or section limited to a maximum of 15 gpm, due to the flow constraints of the equalizers.
  - Example: pumping to a combination system with 3 sections (using 3 D-box outlets). The maximum delivery rate is  $(3 \times 15) = 45$  gpm. Higher flow rates can be accommodated by connecting multiple D-box outlets to each line.
- The rate at which effluent enters the AES pipe shall be controlled. Excessive effluent velocity can disrupt solids that settle in the pipes.

## 2.0 SYSTEM DESIGN

- Effluent shall never be pumped directly into AES pipes.
- A D-box or tank shall be installed between the pumping chamber and the AES pipe to reduce effluent velocity.
- Force mains shall discharge into a D-box (or equivalent) with velocity reducer such as a baffle, 90° bend, tee or equivalent.
- Velocity reducers are also needed for gravity systems when there is excessive slope between the septic tank and the AES system.

Two methods of velocity reduction:

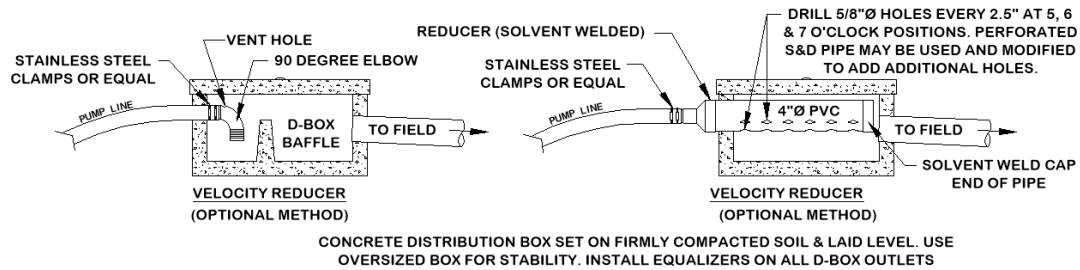

## 2.7 Venting

An adequate air supply is essential to the proper functioning of AES systems. Venting is always required. All systems shall utilize differential venting.

### General Rules

- Differential venting is the use of high and low vents in a system.
- In a gravity system, the roof stack acts as the high vent.
- High and low vent openings shall be separated by a minimum of 10 vertical ft.
- If possible, the high and low vents should be of the same capacity.
- Roof vent diameter must be a minimum of 3 in, 4 in diameter is recommended. If the roof vent is less than 3 in, an additional high vent is recommended.
- Vent openings shall be located to ensure the unobstructed flow of air through the entire system.
- The low vent inlet shall be a minimum of 1 ft above final grade or anticipated snow level. Vents extending more than 3 ft above grade must be anchored.
- Sch. 40 or SDR 35 PVC (or equivalent) should be used for all vent stacks.
- One 4 in vent is required for every 1,000 ft of AES pipe.
- A single 6 in vent may be installed in place of up to three 4 in vents.
- If a vent manifold is used, it shall be at least the same diameter as the vent(s).
- Vent piping should slope downward toward the system to prevent moisture from collecting in the pipe and blocking the passage of air.
- Remote venting may be utilized to minimize the visibility of vent stacks.
- When venting multiple beds, it is preferred that each bed be vented separately rather than connecting bed vents together. Multiple vents can be remotely located to the same location if desired.

### Vent Manifolds

A vent manifold may be incorporated to connect the ends of a number of sections or rows of AES pipe to a single vent opening. Slope the lines connecting the manifold to the AES pipes to drain condensation.

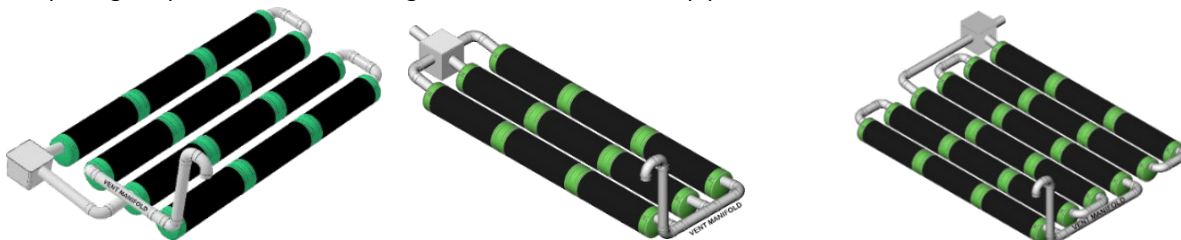



## 2.0 SYSTEM DESIGN

### Gravity Systems Vent Locations

- A low vent is installed at the end of the last row of each section or the end of the last row in a basic serial bed, or at the end of each row in a D-box distribution configuration system. A vent manifold may be used to connect the ends of multiple sections or rows.
- The house (roof) vent functions as the high vent as long as there are no restrictions or other vents between the low vent and the house (roof) vent.
- When the house (roof) vent functions as the high vent, there shall be a minimum of a 10 ft vertical differential between the low and high (roof) vent openings.

Illustration of gravity system air flow:

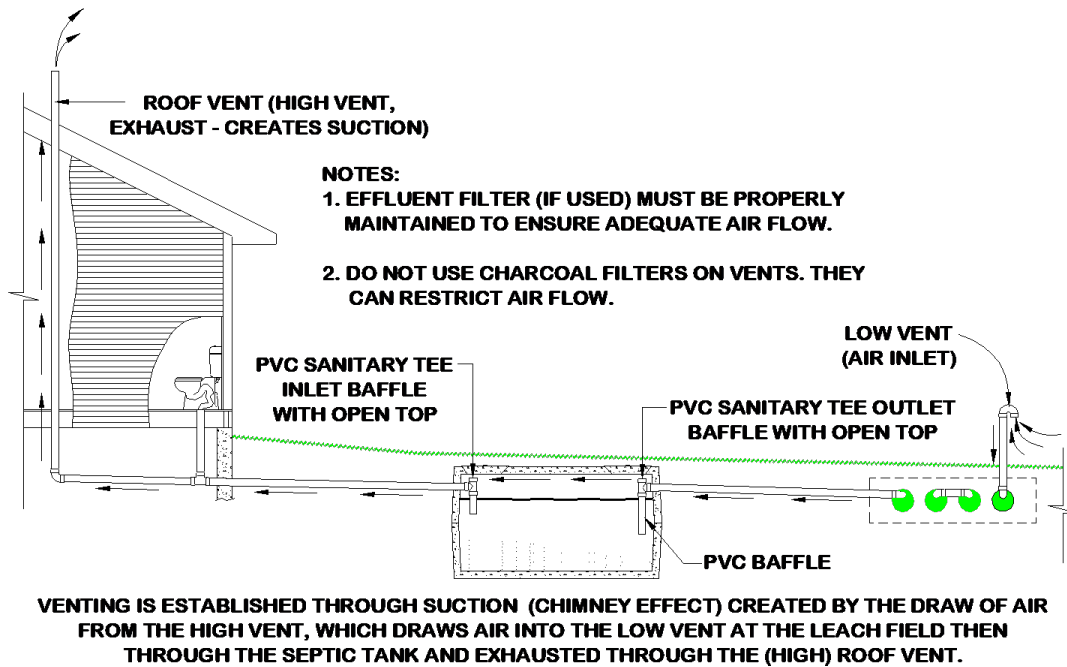

### Pump System Vent Locations

- A low vent is installed through an offset adapter at the end of each section, basic serial bed or attached to a vent manifold.
- A high vent is attached to an unused D-box outlet.
- The low and high vents may be swapped, provided the D-box is insulated against freezing in cold climates.
- For options to relocate the high vent, see Remote Venting.
- For options to eliminate the high vent, see Bypass Venting.

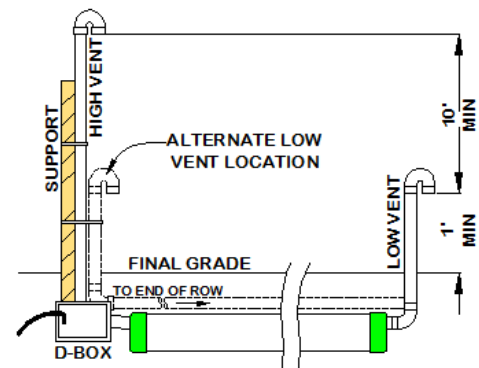

### Remote Venting

If site conditions do not allow the vent pipe to slope toward the system, or the owner chooses to utilize remote venting for aesthetic reasons (causing the vent pipe not to slope toward the system), the low point of the vent line must be drilled creating several  $\frac{1}{4}$  in holes to allow drainage of condensation. This procedure may only be used if the vent pipe connecting to the system has:

- A high point that is above the highest point of all AES pipes or the D-box (2 in minimum for each); and,
- A low point opened for drainage which is above the SHWT (see diagram below).

## 2.0 SYSTEM DESIGN

Illustration of remote venting:

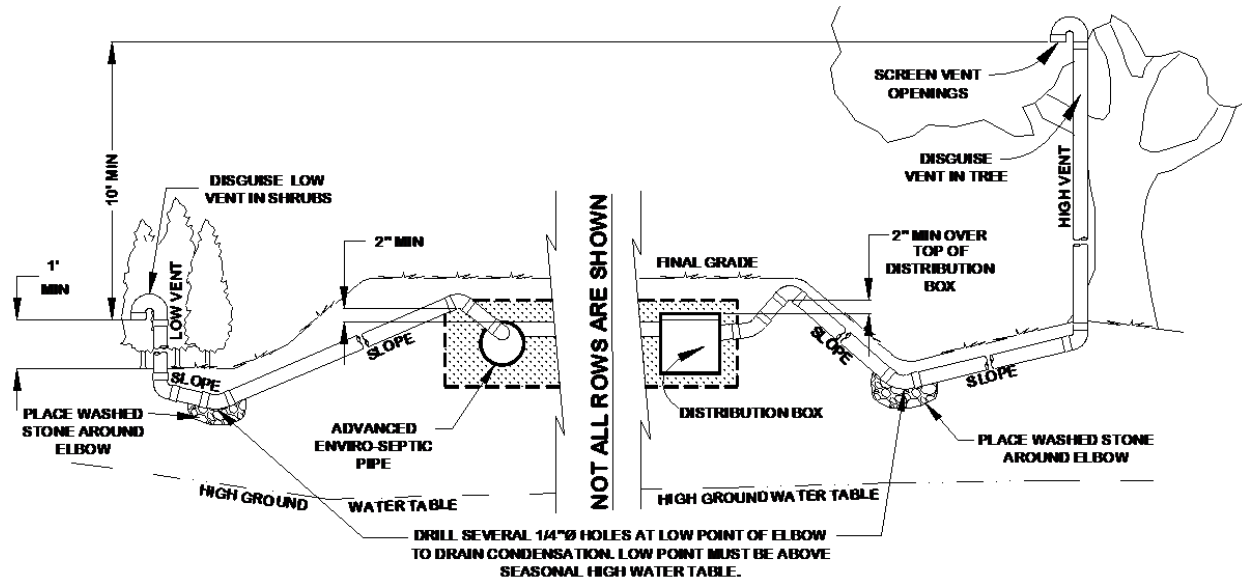

### By-Pass Venting

When a field is fed using pumping or dosing, it is necessary to provide air flow through the system by using either an independent high vent at the field or "by-pass venting". For by-pass venting, the system is plumbed by attaching Sch. 40 or SDR 35 PVC from the D-box back to the septic tank or pump chamber if no effluent filter is present. This process "by-passes" the pump line and allows air to flow from the low vent to the roof vent which functions as the high vent. The bypass vent line invert must rise 2 in above D-box before dropping to pump chamber or septic tank.

Illustration of by-pass venting:

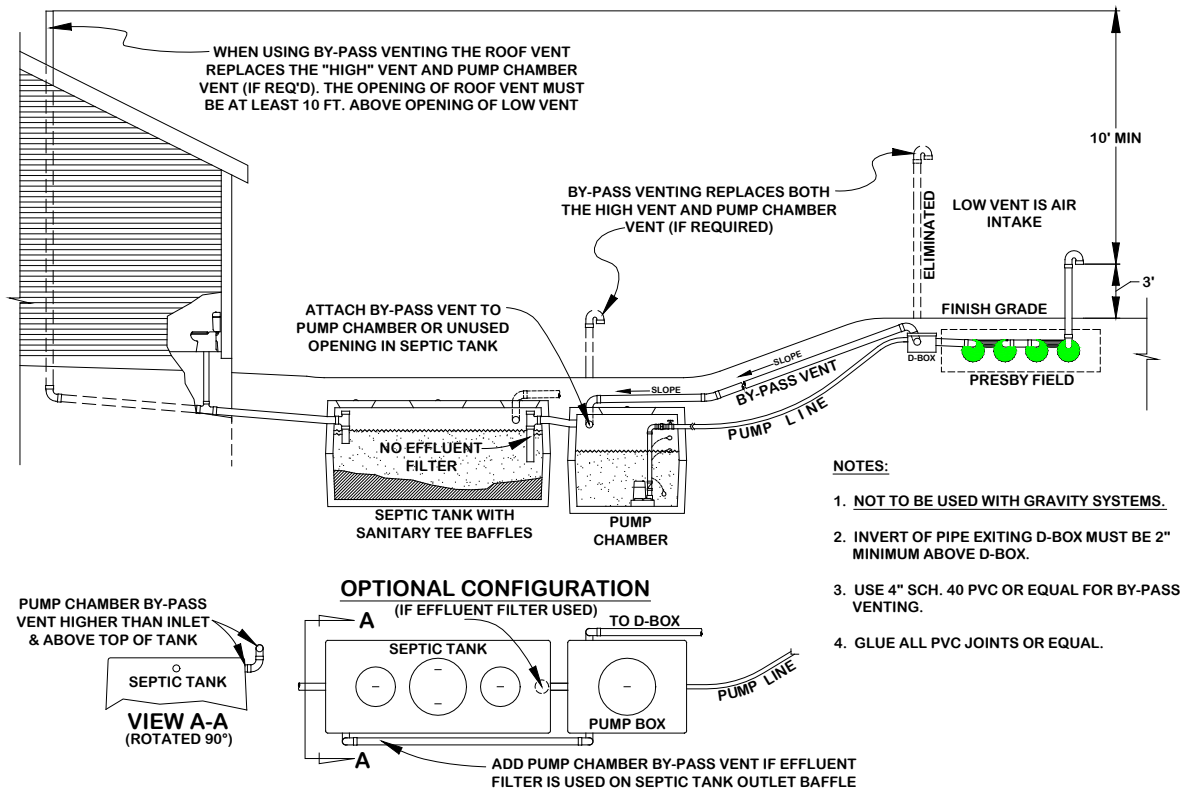

## 2.0 SYSTEM DESIGN

### 2.8 Site Selection

#### Determining Site Suitability

Refer to state or local rules regarding site suitability requirements.

#### Topographic Position Requirement

AES systems shall not be located where surface or ground waters will converge, causing surface water flow to become concentrated or restricted within the soil absorption field. The system shall be located in an area that does not concentrate water, both surface and subsurface. If allowed by state and local authorities, altering the terrain upslope of a system may alleviate this requirement if the waters are sufficiently altered to redirect flows away from the field.

- Locate systems on convex, hill, slope or level locations. Avoid swales, low areas, or toe-of-slope areas that may not provide sufficient drainage away from the system.
- No onsite system may be located on concave slopes that concentrate surface or ground water flows unless up-slope terrain is sufficiently altered or interceptor drains are used to redirect water away from the system.
- Systems should not be located where lawn irrigation, roof drains, or natural flows increase water loading to the soils around the system.
- Divert surface water away from the system. Interceptor drains, if used, must be upslope of the AES system and a minimum of 10 ft away from all AES pipe.
- Systems should not be located where structures such as curbs, walls or foundations might adversely restrict the soil's ability to transport water away from the system.
- Systems should be located to allow access for septic tank maintenance and to at least one end of all AES rows.
- Avoid locating systems in rocky or wooded areas that require additional site work, since this may alter the soil's ability to accept water.
- No trees or shrubs should be located within 10 ft of the system to prevent root infiltration.

#### AES as a Replacement System

If an AES system is being installed in the same location where another onsite system has previously been installed:

- Remove the existing components and contaminated sand and soil.
- If the soils under and around the system have not been compromised, it is permissible to install the AES system in the same excavated location using new system sand.

**Note:** Permits may be required for system replacement.

## 3.0 INSTALLATION

### 3.1 Installation Requirements

#### Component Handling

- Keep mud, grease, oil, etc. away from all components. Avoid dragging pipe through wet or muddy areas. Store pipe on high and dry areas to prevent surface water and soil from entering the pipes or contaminating the fabric prior to installation.
- The outer fabric of the AES pipe is ultra-violet stabilized; however, this protection breaks down after a period of time in direct sunlight. To prevent damage to the fabric, cover the pipe with an opaque tarp if stored outdoors.

#### Site Preparation Prior to Excavation

1. Locate and stake out the system sand bed, extension areas and soil material cover extensions on the site according to the approved plan.
2. Install sediment/erosion control barriers prior to beginning excavation to protect the system from surface water flows during construction.
3. Do not stockpile materials or equipment within the portion of the site receiving system sand.

#### Critical Reminder to Prevent Soil Compaction

It is critical to keep excavators, backhoes, and other equipment off the excavated or tilled surface of a bed. Before installing the system sand, excavation equipment should be operated around the bed perimeter; not on the bed itself. It is especially important to avoid using construction equipment down slope of the system to prevent soil compaction.

#### When to Excavate

- Do not work in wet or frozen soils.
- If a fragment of soil from about 9 in below the surface can easily be rolled into a wire, the soil moisture content is too high for construction.
- Do not excavate the system area immediately after, during or before precipitation.

#### Tree Stumps

Before tilling, remove all grass, leaves, sticks, brush and other organic matter or debris from the excavated system site. Remove all tree stumps and the central root system below grade by using a backhoe or excavator with a mechanical “thumb” or similar extrication equipment, lifting or leveraging stump in a manner that minimizes soil disturbance. It is not necessary for the soil of the system site to be smooth when the site is prepared.

- Avoid soil disturbance, relocation, or compaction.
- Avoid mechanical leveling or tamping of dislodged soil.
- Fill all voids created by stump or root removal with system sand.

#### Raking and Tilling Procedures

All areas receiving system sand, sand fill, side-slope tapering and fill extensions shall be raked or tilled to remove the organic layer (grass, leaves, forest litter, etc.). If a backhoe/excavator is used to till the site, fit it with chisel teeth and till the site. The backhoe/excavator shall remain outside of the proposed system sand area and all areas that will be impacted by side-slope tapering. While tilling, remove all stones larger than 6 in, stumps roots, grass, brush and other organic matter or debris from the excavated system site.

- For in-ground bed systems, excavate the system bed as necessary below original grade. Using an excavator or backhoe, tilt the bucket teeth perpendicular to the bed and use the teeth to rake furrows 2 – 6 in deep into the bottom of the entire area receiving system sand or sand fill.
- For elevated bed systems remove all organics and topsoil (O & A soil horizons) in the footprint of the dispersal area prior to installing system sand; for percolation rates of 61 – 120 MPI, remove the organics, the topsoil may be left in-place and tilled. Next, use an excavator or backhoe to rake furrows 2 in – 6 in deep into the receiving area.

Note: It is not necessary for the soil of the system site to be smooth when the site is prepared.

### 3.0 INSTALLATION

#### Install System Sand and/or Sand Fill Immediately After Excavation

- To protect the tilled area from damage by precipitation, system sand should be installed immediately after tilling. If it is not, repeat the excavation procedures above.
- Work off either end or the uphill side of the system to avoid compacting soil.
- Keep at least 6 in of sand between the vehicle tracks and the tilled soil of the site if equipment must work on receiving soil.
- Track construction equipment should not travel over the installed system area until at least 12 in of cover material is placed over the AES pipes.
- Heavy equipment with tires shall never enter the receiving area due to likely wheel compaction of underlying soil structures.

#### Distribution Box Installation

It is essential that the D-box remain level after installation in order to ensure even distribution to all rows within the system. To prevent movement, D-box shall be set on a layer of level compacted soil, sand, pea gravel base or a concrete footing. Take care when backfilling that the D-box remains level.

#### Row Installation Sequence

1. Install a minimum of 6 in of system sand to the elevation where the bottom of AES pipes will be and install the sand on side-slope tapering to allow machinery movement around the perimeter of the system. Rake the system sand where the AES pipes will be installed so it is as level as possible before placing pipes on the system sand. This will make it easier to level the pipe rows.
2. Locate AES rows horizontally.
3. Locate AES rows vertically using a laser level or transit. Lift or lower the pipes at couplings using a hand shovel and adding or removing system sand as necessary.
4. Drop system sand along each row of couplings being careful to avoid moving the rows.
5. Add or remove system sand along rows to level. The rows may be raised by straddling them and pushing additional system sand below the pipes with your feet. A hand shovel may be scraped along the system sand below the pipes to remove a small amount if needed.
6. Re-check horizontal and vertical locations. Re-check that pipes are level to within 1 in end-to-end.
7. Add system sand between and around the AES pipes, leaving the uppermost surface of the pipe exposed to allow for system inspection (if required by local approving authority).

#### Level Row Tolerances

Use a laser level or transit to install rows level. Variations beyond 1 in ( $\pm\frac{1}{2}$ " ) may affect system performance and are not acceptable.

#### Correct Alignment of AES Bio-Accelerator® Fabric

The Bio-Accelerator (white geo-textile fabric) is to be positioned centered along the bottom of the pipe rows (sewn seam up).

#### Row Spacers

System sand may be used to keep pipe in place while covering, but simple tools may also be constructed for this purpose. Two examples are shown. One is made from rebar, the other from wood. Caution: Remove all tools used as row spacers before final covering.

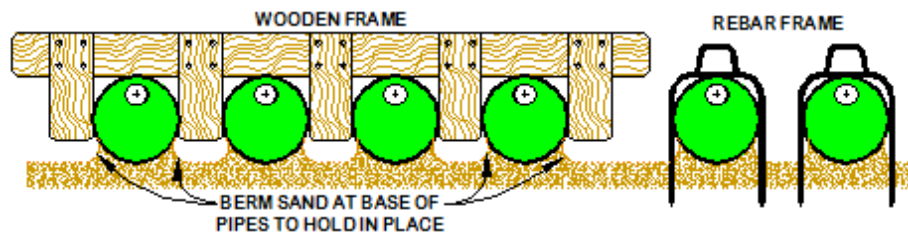

### 3.0 INSTALLATION

#### Connect Rows Using Raised Connections

Raised connections consist of offset adapters, 4 in PVC sewer and drainpipe or Sch. 20-40 PVC, and 90° elbows. They enable greater liquid storage capacity and increase the bacterial surfaces being developed. Use raised connections to connect the rows of basic serial and combination serial configurations. Raised connections extend 2 in to 4 in into pipe and are installed on an angle (as shown in the drawing to the right). The top of the raised connections should be level with the top of the AES pipe as shown. All PVC joints should be glued or mechanically fastened.

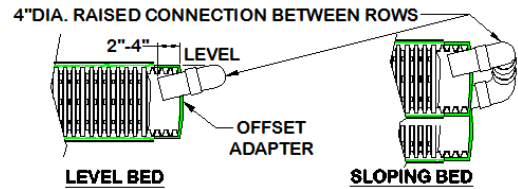

#### Raised Straight Connection

A raised straight connection is a PVC sewer & drain pipe configuration which is used to connect AES rows that are placed end to end along the same contour. Raised straight connections extend 2 in to 4 in into pipe and are installed on an angle (as shown in the drawings to the right). All PVC joints should be glued or mechanically fastened.

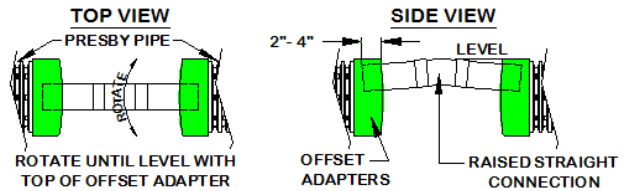

#### Backfilling Rows

1. Spread system sand between the rows.
2. Confirm pipe rows are positioned with Bio-Accelerator along the bottom (sewn seam up).
3. Straddle each row of pipe and walk heel-to-toe its entire length, ensuring that system sand fills all void spaces beneath the AES pipe.
4. Finish spreading system sand to the top of the rows and leave them exposed for inspection purposes.
5. Confirm that all rows of pipe are level to within 1 in end-to-end.
6. After inspection (if required) proceed to backfilling and final grading.

#### Backfilling and Final Grading

1. After the installed system has been inspected, spread system sand to a minimum of 3 in over the pipe and a minimum of 6 in on all four sides of the bed beyond the AES pipes. Do not install any barrier materials on top of the system sand.
2. Spread minimum of 4 in of suitable earth cover (topsoil or loam) free of organics, stones over 4 in and building debris, having a texture similar to the soil at the site, without causing compaction. Topsoil shall be crowned to a minimum depth of 12 in over the pipe.
3. To prevent erosion, soil cover above the system shall be immediately planted with native, shallow-rooted vegetation such as grass, wildflowers and certain perennials or ground covers. No trees or shrubs should be located within 10 ft of the system perimeter to prevent roots from growing into and damaging the system.

#### Fill Extensions Requirements

All systems with any portion of the system sand bed above original grade require 6 in fill extensions on each side beyond the outside edge of all AES pipes and then tapering to meet existing grade at a maximum slope of 3:1. There must be a minimum of 12 in of cover material over the ends of all system sand extensions (if present).

## 4.0 REJUVENATION AND EXPANSION

### 4.1 *Bacteria Rejuvenation and Expansion*

#### **Why Would System Bacteria Rejuvenation Be Needed?**

Bacteria rejuvenation is the return of bacteria to an aerobic state. Flooding, improper venting, alteration or improper depth of soil material cover, use of incorrect sand, sudden use changes, introduction of chemicals or medicines, and a variety of other conditions can contribute to converting bacteria in any system from an aerobic to an anaerobic state. This conversion severely limits the bacteria's ability to effectively treat effluent, as well as limits liquids from passing through. A unique feature of the AES system is its ability to be rejuvenated in place.

#### **How to Rejuvenate System Bacteria**

System bacteria are "rejuvenated" when they return to an aerobic state. By using the following procedure, this can be accomplished in most AES systems without costly removal and replacement.

1. Contact PEI before attempting rejuvenation for technical assistance.
2. Determine and rectify the problem(s) causing the bacteria conversion.
3. Have system and septic tank pumped by a registered septage pumper.
4. Drain the system by excavating at least one end of all the rows and removing the offset adapters.
5. If foreign matter has entered the system, flush the pipes.
6. Safeguard the open excavation.
7. Guarantee a passage of air through the system.
8. Allow all rows to dry for 72 hours minimum. The system sand should return to its natural color.
9. Re-assemble the system to its original design configuration. As long as there is no physical damage to the AES components, the original components may be reused.

#### **System Expansion**

AES systems are easily expanded by adding equal lengths of pipe to each row of the original design or by adding additional equal sections. All system expansions shall comply with state and local regulations. Permits may be required prior to system expansion.

#### **Reusable Components**

AES pipe and components are not biodegradable and may be reused. In cases of improper installation, it may be possible to excavate, clean, and reinstall all system components.

#### **System Replacement**

If an AES system requires replacement...

- Remove the existing components and contaminated sand
- If the soils under and around the system have not been compromised, replace in the same excavated location with new system sand.
- If components are not damaged, they may be cleaned and reused.

*Note: Permits may be required for system replacement.*

## 5.0 OPERATION AND MAINTENANCE

### 5.1 Operation and Maintenance

#### Proper Use

AES systems do not require a maintenance and monitoring agreement, however they do require minimal maintenance as is standard for conventional onsite systems, provided the system is not subjected to abuse. An awareness of proper use and routine maintenance will guarantee system longevity. We encourage all system owners and service providers to obtain and review a copy of our Owner's Manual, available from our website [www.presbyeco.com](http://www.presbyeco.com) or via mail upon request to (800) 473-5298 or [info@presbyeco.com](mailto:info@presbyeco.com).

#### System Abuse Conditions

The following conditions constitute system abuse:

- Liquid in high volume (excessive number of occupants and use of water in a short period of time, leaking fixtures, whirlpool tubs, hot tubs, water softening equipment or additional water discharging fixtures if not specified in system design).
- Solids in high volume (excessive number of occupants, paper products, personal hygiene products, garbage disposals or water softening equipment if not specified in system design).
- Antibiotics and medicines in high concentrations.
- Cleaning products in high concentrations.
- Fertilizers or other caustic chemicals in any amount.
- Petroleum products in any amount.
- Latex and oil paints.
- System suffocation (compacted soils, barrier materials, etc.) without proper venting.

Note: PEI does not recommend the use of septic system additives.

#### System Maintenance/Pumping of the Septic Tank

- Inspect the septic tank at least once every two years under normal usage.
- Pump the tank when surface scum and bottom sludge occupy one-fourth or more of the liquid depth of the tank.
- If a garbage disposal is used, the septic tank will likely require more frequent pumping.
- After pumping, inspect the septic tank for integrity to ensure that no groundwater is entering it. Also check the integrity of the tank inlet and outlet baffles and repair if needed.
- Inspect the system to ensure that vents are in place and free of obstructions.
- Effluent filters require ongoing maintenance due to their tendency to clog and cut off oxygen to the system. Follow filter manufacturer's maintenance instructions and inspect filters frequently.

#### Site Maintenance

It is important that the system site remain free of shrubs, trees, and other woody vegetation, including the entire SSBA, and areas impacted by side slope tapering and perimeter drains (if used). Roots can infiltrate and cause damage or clogging of system components. If a perimeter drain is used, it is important to make sure that the outfall pipes are screened to prevent animal activity. Also check outfall pipes regularly to ensure that they are not obstructed in any way.



## **6.0 WARRANTY**

### **6.1 PRESBY ENVIRONMENTAL INC. STANDARD LIMITED WARRANTY**

(a) The structural integrity of each unit, endcap and other accessory manufactured by Presby Environmental Inc. (collectively referred to as “Units”), when installed and operated in an onsite wastewater system in accordance with Presby Environmental’s installation instructions, is warranted to the original purchaser (“Holder”) against defective materials and workmanship for one year from the date upon which a septic permit is issued for the septic system containing the Units; provided, however, that if a septic permit is not required for the septic system by applicable law, the one (1) year warranty period will begin upon the date that installation of the septic system commences. In order to exercise its warranty rights, Holder must notify Presby Environmental in writing at its corporate headquarters in Whitefield, New Hampshire within fifteen (15) days of the alleged defect. Presby Environmental will supply replacement Units for those Units determined by Presby Environmental to be defective and covered by this Limited Warranty. Presby Environmental’s liability specifically excludes the cost of removal and/or installation of the Units.

(b) THE LIMITED WARRANTY AND REMEDIES IN SUBPARAGRAPH (a) ARE EXCLUSIVE. THERE ARE NO OTHER WARRANTIES WITH RESPECT TO THE UNITS, INCLUDING NO IMPLIED WARRANTIES OF MERCHANTABILITY OR FITNESS FOR A PARTICULAR PURPOSE.

(c) This Limited Warranty shall be void if any part of the Presby Environmental system (unit, endcap or other accessory) is manufactured by anyone other than Presby Environmental. The Limited Warranty does not extend to incidental, consequential, special or indirect damages. Presby Environmental shall not be liable for penalties or liquidated damages, including loss of production and profits, labor and materials, overhead costs, or other losses or expenses incurred by the Holder or any third party. Specifically excluded from Limited Warranty coverage are damage to the Units due to ordinary wear and tear, alteration, accident, misuse, abuse or neglect of the Units; the Units being subjected to vehicle traffic or other conditions which are not permitted by the installation instructions; failure to maintain the minimum ground covers set forth in the installation instructions; the placement of improper materials into the system containing the Units; failure of the Units or the septic system due to improper siting or improper sizing, excessive water usage, improper grease disposal, or improper operation; or any other event not caused by Presby Environmental. This Limited Warranty shall be void if the Holder fails to comply with all of the terms set forth in this Limited Warranty.

Further, in no event shall Presby Environmental be responsible for any loss or damage to the Holder, the Units, or any third party resulting from installation or shipment, or from any product liability claims of Holder or any third party. For this Limited Warranty to apply, the Units must be installed in accordance with all site conditions required by state and local codes; all other applicable laws; and Presby Environmental’s installation instructions.

(d) No representative of Presby Environmental has the authority to change this Limited Warranty in any manner whatsoever, or to extend this Limited Warranty. No warranty applies to any party other than the original Holder.

The above represents the standard Limited Warranty offered by Presby Environmental. A limited number of states and counties have different warranty requirements. Any purchaser of Units should contact Presby Environmental’s corporate headquarters in Whitefield, New Hampshire, prior to such purchase, to obtain a copy of the applicable warranty, and should carefully read that warranty prior to the purchase of Units.