

# The Presby Wastewater Treatment System

## Design and Installation Specifications for Advanced Enviro-Septic®, Enviro-Septic® and Simple-Septic® Wastewater Treatment Systems



✓ Minimizes the Expense

✓ Protects the Environment ✓

Preserves the Site



## Presby Environmental, Inc.

*The Next Generation of Wastewater Treatment Technology*

143 Airport Rd., Whitefield, NH 03598  
Tel: 800-473-5298 Fax: 603-837-9864  
info@presbyeco.com  
www.PresbyEnvironmental.com

The information in this manual is subject to change without notice. We recommend that you check your State's page on our website on a regular basis for updated information. Your suggestions and comments are welcome. Please contact us at: 800-473-5298

Presby Environmental, Inc.  
143 Airport Road  
Whitefield, NH 03598  
Phone: 1-800-473-5298 Fax: (603) 837-9864  
Website: [www.PresbyEnvironmental.com](http://www.PresbyEnvironmental.com)

The products and methods depicted in this manual are protected by one or more patents. For more information:  
Pat. [www.presbyeco.com/patents](http://www.presbyeco.com/patents).

**Advanced Enviro-Septic® is a registered trademark of Presby Environmental Inc.  
Enviro-Septic® is a registered trademark of Presby Environmental, Inc.  
Simple-Septic® is a registered trademark of Presby Environmental Inc.**

**IMPORTANT NOTICE:** This Manual is intended **ONLY** for use in designing and installing Presby Environmental's Advanced Enviro-Septic®, Enviro-Septic® and Simple-Septic® Wastewater Treatment Systems. The use of this Manual with any other product is prohibited. The processes and design criteria contained herein are based solely on our experience with and testing of Advanced Enviro-Septic®, Enviro-Septic® and Simple-Septic®. Substitution of any other large diameter gravelless pipe will result in compromised treatment of wastewater and other adverse effects.

**© Presby Environmental, Inc. June 2015  
All Rights Reserved**

**Date of Issue: June 16, 2015**

## TABLE OF CONTENTS

<u>Section Number</u>	<u>Page Number</u>
1.0	Background.....1
2.0	Ten Stages of Wastewater Treatment.....2
3.0	Presby System Components.....3
4.0	Table A - System Sand Bed Area and Bed Configuration Requirements.....5
5.0	Table B: Presby Pipe Requirements (Single & Multi-Level™).....5
6.0	Table C: Row Length and Pipe Layout Width (Single Level).....5
7.0	Table D: Row Length and Pipe Layout Width for two level Multi-Level™ System.....6
8.0	Design Procedure and Examples.....6
9.0	Presby Environmental Standards and Technical Support.....7
10.0	Certification Requirements.....7
11.0	Design Criteria .....7
12.0	Basic Serial Distribution (Single Level) .....10
13.0	Basic Serial Distribution (Multi-Level™).....10
14.0	Bottom Drain .....11
15.0	Butterfly Configuration.....11
16.0	Combination Serial Distribution (Single Level) .....12
17.0	Segmented Row Option .....13
18.0	Combination Serial Distribution (Multi-Level™).....14
19.0	D-Box Distribution (Single Level) .....14
20.0	Multiple Bed Distribution .....15
21.0	Elevated Bed Systems (Mounds).....15
22.0	In-Ground Bed Systems.....16
23.0	Angled and Curving Beds .....16
24.0	Curved Beds .....16
25.0	Non-Conventional System Configurations .....17
26.0	H-20 Loading .....17
27.0	Pumped System Requirements .....17
28.0	System Sand and Sand Fill Requirements for All Beds .....18
29.0	Venting Requirements.....18
30.0	Site Selection .....21
31.0	Installation Requirements, Component Handling and Site Preparation .....21
32.0	System Bacteria Rejuvenation and Expansion .....23
33.0	System Expansion .....23
34.0	Operation & Maintenance .....24
35.0	Glossary.....24

## **1.0 Background**

Liquid that exits from a septic tank ("effluent") contains suspended solids that can cause traditional systems to fail prematurely. Solids can overload bacteria, cut off air required for aerobic bacterial activity, and/or seal the underlying soil, interfering with its ability to absorb liquid.

### **1.1 What Our System Does**

By utilizing simple yet effective natural processes, the Presby Treatment System treats septic tank effluent in a manner that prevents suspended solids from sealing the underlying soil, increases system aeration, and provides a greater bacterial treatment area ("biomat") than traditional systems.

### **1.2 Why Our System Excels**

The Presby Treatment System retains solids in its pipe and provides multiple bacterial surfaces to treat effluent prior to its contact with the soil. The continual cycling of effluent (the rising and falling of liquid inside the pipe) enhances bacterial growth. This all combines to create a unique eco-system that no other passive wastewater treatment system is designed to offer. The result is a system that excels by being more efficient, lasting longer, and has a minimal environmental impact.

### **1.3 System Advantages**

- a) costs less than traditional systems
- b) eliminates the need for washed stone
- c) often requires a smaller area
- d) installs more easily and quickly than traditional systems
- e) adapts easily to residential and commercial sites of virtually any size
- f) adapts well to difficult sites
- g) develops a protected receiving surface preventing sealing of the underlying soil
- h) blends "septic mounds" into sloping terrain
- i) increases system performance and longevity
- j) tests environmentally safer than traditional systems
- k) recharges groundwater more safely than traditional systems
- l) made from recycled plastic

### **1.4 Patented Presby Technology**

At the heart of Advanced Enviro-Septic®, Enviro-Septic®, or Simple-Septic® is a patented corrugated, perforated plastic pipe with interior skimmer tabs and cooling ridges. All Presby Pipe is surrounded by one or more filtering, treatment and dispersal layers. Presby Systems are completely passive, requiring no electricity, motors, alarms, computers, etc. Presby Pipes are assembled and installed in a bed of specified System Sand which can either be below the ground or above.

### **1.5 Advanced Enviro-Septic® (AES)**

The Advanced Enviro-Septic® pipe is assembled into an onsite wastewater treatment system that has been successfully tested and certified to NSF 40, Class I (a certification typically given to mechanical aeration devices), BNQ of Quebec, Class I, II, III and Cebedeau, Belgium standards. Advanced Enviro-Septic® is comprised of corrugated, perforated plastic pipe, Bio-Accelerator® fabric along its bottom which is surrounded by a layer of randomized plastic fibers and a sewn geo-textile fabric. Advanced Enviro-Septic® creates an eco-system designed to simultaneously purify and disperse effluent after primary treatment by a septic tank. Advanced Enviro-Septic® is the "next generation" of our Enviro-Septic® technology. The AES product incorporates Bio-Accelerator®, a proprietary enhancement that screens additional solids from effluent, accelerates treatment processes, assures even distribution and provides additional surface area. Each foot of Advanced Enviro-Septic® pipe provides over 40 sq ft of total surface area for bacterial activity.

### **1.6 Enviro-Septic® (ES)**

The Enviro-Septic® pipe is assembled into an onsite wastewater treatment system. Enviro-Septic® is comprised of corrugated, perforated plastic pipe which is surrounded by a layer of randomized plastic fibers and a sewn geo-textile fabric. The system is designed to simultaneously purify and disperse effluent after primary treatment by a septic tank. Each foot of Enviro-Septic® pipe provides over 25 sq ft of total surface area for bacterial activity.

### **1.7 Simple-Septic® (SS)**

Simple-Septic® pipe is a single layer geo-textile fabric distribution system after primary treatment by a septic tank. Simple-Septic® is similar to other single-layer fabric, large diameter, gravelless pipe (LDGP) systems on the market today, yet provides the added benefit of Presby's patented skimmer tabs and cooling ridges to protect the bacterial surface area of the fabric. Each foot of Simple-Septic® pipe provides over 15 sq ft of total surface area for bacterial activity.

2.0 Ten Stages of Wastewater Treatment

# The Presby Wastewater Treatment System's 10 STAGES OF TREATMENT

Advanced Enviro-Septic® (AES), Enviro-Septic® (ES) and Simple-Septic® (SS)

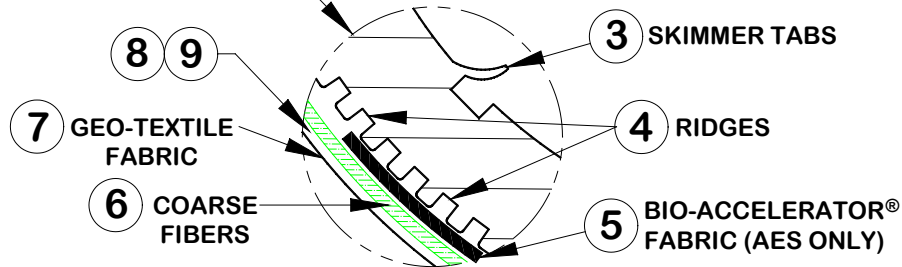
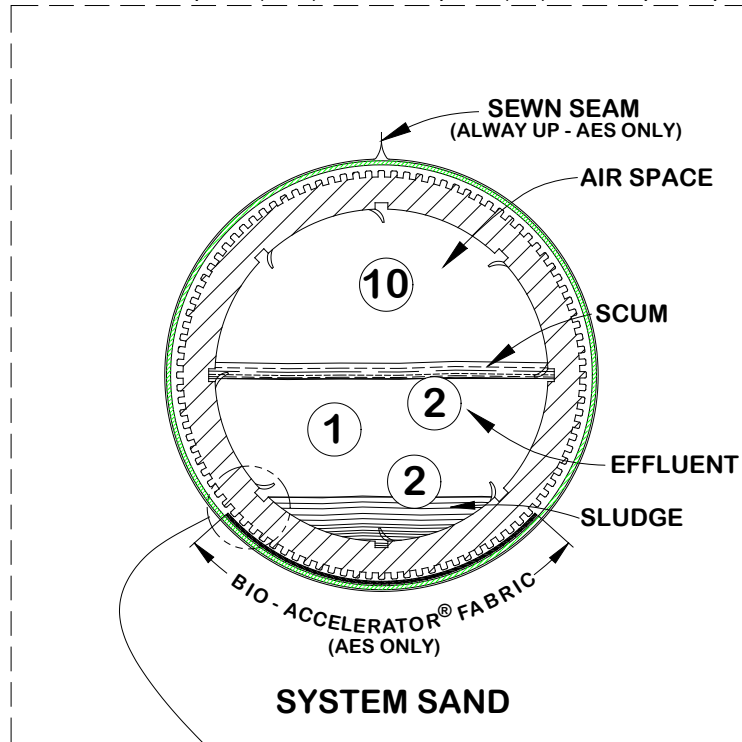

- Stage 1:** Warm effluent enters the pipe and is cooled to ground temperature.
- Stage 2:** Suspended solids separate from the cooled liquid effluent.
- Stage 3:** Skimmers further capture grease and suspended solids from the existing effluent.
- Stage 4:** Pipe ridges allow the effluent to flow uninterrupted around the circumference of the pipe and aid in cooling.
- Stage 5:** Bio-Accelerator® fabric screens additional solids from the effluent, enhances and accelerates treatment, facilitates quick start-up after periods of non-use, provides additional surface area for bacterial growth, promotes even distribution, and further protects outer layers and the receiving surfaces so they remain permeable. (AES only)
- Stage 6:** A mat of coarse, randomly-oriented fibers separates more suspended solids from the effluent. (AES & ES only)
- Stage 7:** Effluent passes into the geo-textile fabrics and grows a protected bacterial surface.
- Stage 8:** Sand wicks liquid from the geo-textile fabrics and enables air to transfer to the bacterial surface.
- Stage 9:** The fabrics and fibers provide a large bacterial surface to break down solids.
- Stage 10:** An ample air supply and fluctuating liquid levels increase bacterial efficiency.

### 3.0 Presby System Components

#### 3.1 Advanced Enviro-Septic®, Enviro-Septic® and Simple-Septic® Pipe

- a) Plastic pipe made with a significant percentage of recycled material
- b) 10 ft sections (can be cut to any length)
- c) Ridged and perforated, with skimmer tabs on interior
- d) AES only: Bio-Accelerator® along bottom of pipe (sewn seam always placed up).
- e) AES & ES only: Surrounded by a mat of randomly-oriented plastic fibers
- f) Wrapped in a non-woven geo-textile fabric stitched in place
- g) Exterior diameter of 12 in.
- h) Each 10 ft section has a liquid holding capacity of approx. 58 gallons
- i) A 10 ft length of AES, ES or SS pipe is flexible enough to bend up to 90°



#### 3.2 Offset Adapter

An offset adapter is a plastic fitting 12 in. in diameter with an inlet hole designed to accept a 4 inch sewer line, raised connection or vent pipe. The hole is to be installed in the 12 o'clock position. The distance from the bottom of the Offset Adapter to the bottom of its inlet hole is 7 in. When assembling pipes into rows, note that the geo-textile fabrics are placed over the edges of the Offset Adapter and Couplings.



#### 3.3 Double Offset Adapter

A double offset adapter is a plastic fitting 12 in. in diameter with two 4 in. holes designed to accept a 4 in. inlet pipe, raised connection, vent or vent manifold, and/or bottom drain, depending upon the particular requirements of the design configuration. The 4 in. holes are to be aligned in the 12 o'clock and 6 o'clock positions. The holes are positioned 1 in. from the outside edge of the double offset adaptor and 2 in. from each other.



#### 3.4 Coupling

A coupling is a plastic fitting used to create a connection between two pieces of Presby Pipe. Note that the couplings are wide enough to cover 1 or 2 pipe corrugations on each of the two pipe ends being joined. The couplings feature a snap-lock feature that requires no tools. When assembling pipes into rows, note that the geo-textile fabric does not go under couplings. Pull fabric back, install coupling, and then pull fabric over coupling. Also note, during installation in cold weather, couplings are easier to work with if stored in a heated location (such as a truck cab) before use.



#### 3.5 Distribution Box

A Distribution Box, also called a "D-box," is a device used to distribute effluent coming from the septic tank in a system that contains more than one section or more than one bed. D-boxes are also sometimes used for velocity reduction. D-boxes come in various sizes and with a varying number of outlets. Concrete D-boxes are preferred, some are made of plastic. Flow equalizers (see next page) are installed in the D-box openings to equalize distribution; they help ensure equal distribution in the event that the D-box settles or otherwise becomes out of level. Unused openings in D-boxes are to be covered, plugged or mortared. A distribution box is only required when dividing flow to more than one section of the Presby bed.

#### 3.6 Flow Equalizers

All Presby Systems with Combination Serial distribution or Multiple Bed distribution must use Flow Equalizers in each distribution box outlet. A flow equalizer is an adjustable plastic insert installed in the outlet holes of a distribution box to equalize effluent distribution to each outlet whenever flow is divided. Each Bed or section of Combination Serial distribution is limited to a maximum of 15 gallons per minute, due to the flow constraints of the equalizers. Example: pumping to a combination system with 3 sections (using 3 D-Box outlets). The maximum delivery rate is  $(3 \times 15) = 45$  GPM. Always provide a means of velocity reduction when needed.



#### 3.7 Manifolder Splitter Box

A manifolded splitter box joins several outlets of a D-box to help divide flow more accurately. Dividing flow to multiple beds is a common use of splitter boxes. All outlets delivering effluent to the Presby field must have a flow equalizer. Do not place an equalizer on vent outlets.

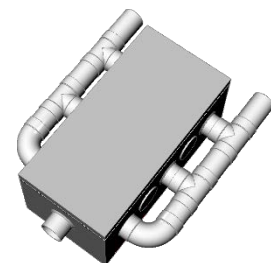

### 3.8 Raised Connection

A raised connection is a PVC Sewer & Drain pipe configuration which is used to connect Presby Rows. Raised connections extend 2 in. to 4 in. into pipe and are installed on an angle (as shown below). All PVC joints should be glued or mechanically fastened.

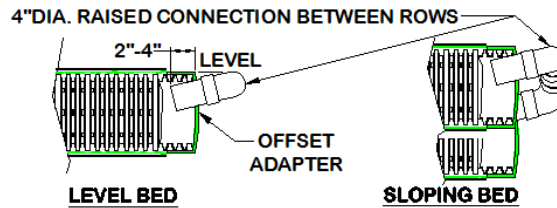

### 3.9 Raised Straight Connection

A raised straight connection is a PVC Sewer & Drain pipe configuration which is used to connect Presby Rows that are placed end to end along the same contour. Raised straight connections extend 2 in. to 4 in. into pipe and are installed on an angle (as shown below). All PVC joints should be glued or mechanically fastened. Offset Adapters will accept 4 inch schedule 40 PVC if the edge to be inserted into the adapter is rounded.

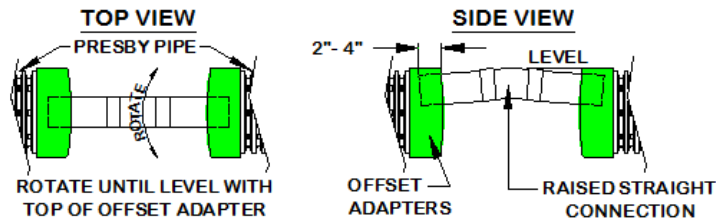

### 3.10 Septic Tank

The Advanced Enviro-Septic® System is designed to treat effluent that has received “primary treatment” in a standard septic tank. Unless specified by State/local regulations, the septic tank capacity should be:

- No less than 1,000 gallons
- 2.5 times Daily Design Flow for systems up to 5,000 GPD (gallons per day)
- 2.0 times the Daily Design Flow for systems 5,001 to 10,000 GPD
- 1.75 times the Daily Design Flow for systems over 10,000 GPD.
- Septic tank capacity should be increased by 50% if a garbage disposal is used.
- Septic tanks used with the Advanced Enviro-Septic® System must be fitted with inlet and outlet baffles in order to retain solids in the septic tank and to prevent them from entering the Advanced Enviro-Septic® System.
- Effluent filters are not recommended by Presby Environmental, Inc. due to their tendency to clog, which cuts off the oxygen supply that is essential to the functioning of the Advanced Enviro-Septic® System.
- If you are required to use an effluent filter in a gravity fed system due to State or local requirements, the effluent filter selected must allow the free passage of air to ensure the proper functioning of the system.

### 3.11 System Sand

The System Sand that surrounds the Advanced Enviro-Septic® pipes is an **essential** component of the system. It is **critical** that the correct type and amount of System Sand is used during construction. System Sand must be coarse to very coarse, clean, granular sand, free of organic matter. System Sand is placed a minimum of 6 in. in all directions from the Advanced Enviro-Septic® pipes (below pipes, between rows, above pipes and around outer perimeter). It must adhere to **all** of the following percentage and quality restrictions:

**Presby System Sand Specification**

Sieve Size	Percent Retained on Sieve (by weight)
3/4 in. (19 mm)	0
#10 (2 mm)	0 - 35
#35 (0.50 mm)	40 - 90
Note: not more than 3% allowed to pass the #200 sieve (verified by washing sample per requirements of ASTM C-117)	

### 3.12 System Sand Acceptable Alternative

ASTM C-33 (concrete sand), natural or manufactured sand, with not more than 3% passing the #200 sieve (verified by washing the sample per the requirements of ASTM C-117 as noted in the ASTM C-33 specification) may be used as an acceptable alternate material for use as System Sand.

**4.0 Table A - System Sand Bed Area and Bed Configuration Requirements**

Soil Texture	Percolation Rate Minutes per Inch (MPI)	Application Rate (GPD/sf)	% System Slope Maximum	% Site Slope Maximum	Bed Configurations Allowed
Sand, Loamy Sand	Up to 10	6.74	25	33	All Single and Multi-Level™ Layouts
	11 - 15	4.49			
Sandy Loam, Loam	16 - 20	3.37			
	21 - 25	2.69			
	26 - 30	2.25			
Sandy Clay Loam, Silty Loam, Silty Clay Loam, Clay Loam	31 - 35	1.92	20	25	Single Level Conventional Layouts
	36 - 40	1.68			
	41 - 45	1.50	15	20	
	46 - 50	1.35			
	51 - 55	1.22	10	15	
Sandy Clay, Silty Clay, Clay	56 - 60	1.12	5	5	750 GPD maximum bed size using Single Level Basic Serial or Parallel Layouts
	61 - 65	1.04			
	66 - 70	0.96			
	71 - 75	0.90			
	76 - 80	0.84			
	81 - 85	0.79			
	86 - 90	0.75			
	91 - 95	0.71			
	96 - 100	0.67			
	101 - 105	0.64			
	106 - 110	0.61			
111 - 115	0.59				
116 - 120	0.56				

For hydraulic loading consult your local On-site Wastewater Treatment System (OWTS) rules. Contact Presby Environmental for percolation rates over 120 MPI or soil application rates slower than 0.56 GPD/ft² for technical assistance.

**5.0 Table B: Presby Pipe Requirements (Single & Multi-Level™)**

System Type	Presby Pipe Loading Rate GPD/ft
Residential System	3
Commercial System	3

Assumes residential strength effluent (see para. 11.6, page 8 for definition of residential strength). Contact Presby Environmental for technical assistance with high strength wastewater.

**6.0 Table C: Row Length and Pipe Layout Width (Single Level)**

		Total Linear Feet of Presby Pipe														
Row Length (ft)	# of Rows	2	3	4	5	6	7	8	9	10	11	12	13	14	15	
	20	20	40	60	80	100	120	140	160	180	200	220	240	260	280	300
	25	25	50	75	100	125	150	175	200	225	250	275	300	325	350	375
	30	30	60	90	120	150	180	210	240	270	300	330	360	390	420	450
	35	35	70	105	140	175	210	245	280	315	350	385	420	455	490	525
	40	40	80	120	160	200	240	280	320	360	400	440	480	520	560	600
	45	45	90	135	180	225	270	315	360	405	450	495	540	585	630	675
	50	50	100	150	200	250	300	350	400	450	500	550	600	650	700	750
	55	55	110	165	220	275	330	385	440	495	550	605	660	715	770	825
	60	60	120	180	240	300	360	420	480	540	600	660	720	780	840	900
	65	65	130	190	260	325	390	455	520	585	650	715	780	845	910	975
	70	70	140	210	280	350	420	490	560	630	700	770	840	910	980	1050
	75	75	150	225	300	375	450	525	600	675	750	825	900	975	1050	1125
	80	80	160	240	320	400	480	560	640	720	800	880	960	1040	1120	1200
	85	85	170	255	340	425	510	595	680	765	850	935	1020	1105	1190	1275
	90	90	180	270	360	450	540	630	720	810	900	990	1080	1170	1260	1350
95	95	190	285	380	475	570	665	760	855	950	1045	1140	1235	1330	1425	
100	100	200	300	400	500	600	700	800	900	1000	1100	1200	1300	1400	1500	
Spacing (ft)	# of Rows	2	3	4	5	6	7	8	9	10	11	12	13	14	15	
1.50	1.50	2.50	4.00	5.50	7.00	8.50	10.00	11.50	13.00	14.50	16.00	17.50	19.00	20.50	22.00	
1.75	1.75	2.75	4.50	6.25	8.00	9.75	11.50	13.25	15.00	16.75	18.50	20.25	22.00	23.75	25.50	
2.00	2.00	3.00	5.00	7.00	9.00	11.00	13.00	15.00	17.00	19.00	21.00	23.00	25.00	27.00	29.00	
2.25	2.25	3.25	5.50	7.75	10.00	12.25	14.50	16.75	19.00	21.25	23.50	25.75	28.00	30.25	32.50	
2.50	2.50	3.50	6.00	8.50	11.00	13.50	16.00	18.50	21.00	23.50	26.00	28.50	31.00	33.50	36.00	
2.75	2.75	3.75	6.50	9.25	12.00	14.75	17.50	20.25	23.00	25.75	28.50	31.25	34.00	36.76	39.50	
3.00	3.00	4.00	7.00	10.00	13.00	16.00	19.00	22.00	25.00	28.00	31.00	34.00	37.00	40.00	43.00	

Ex: select a row length and move right until the minimum amount of pipe is found (more is allowed). Then move down to find the number of rows required; continue downward in the same column to find the pipe layout width for your spacing (1.5 ft minimum, larger spacing is allowed at the discretion of the designer).



**7.0 Table D: Row Length and Pipe Layout Width for two level Multi-Level™ System**

		Total Linear Feet of Presby Pipe													
Row Length (ft)	20	40	60	80	100	120	140	160	180	200	220	240	260	280	300
	25	50	75	100	125	150	175	200	225	250	275	300	325	350	375
	30	60	90	120	150	180	210	240	270	300	330	360	390	420	450
	35	70	105	140	175	210	245	280	315	350	385	420	455	490	525
	40	80	120	160	200	240	280	320	360	400	440	480	520	560	600
	45	90	135	180	225	270	315	360	405	450	495	540	585	630	675
	50	100	150	200	250	300	350	400	450	500	550	600	650	700	750
	55	110	165	220	275	330	385	440	495	550	605	660	715	770	825
	60	120	180	240	300	360	420	480	540	600	660	720	780	840	900
	65	130	195	260	325	390	455	520	585	650	715	780	845	910	975
	70	140	210	280	350	420	490	560	630	700	770	840	910	980	1050
	75	150	225	300	375	450	525	600	675	750	825	900	975	1050	1125
	80	160	240	320	400	480	560	640	720	800	880	960	1040	1120	1200
	85	170	255	340	425	510	595	680	765	850	935	1020	1105	1190	1275
	90	180	270	360	450	540	630	720	810	900	990	1080	1170	1260	1350
95	190	285	380	475	570	665	760	855	950	1045	1140	1235	1330	1425	
100	200	300	400	500	600	700	800	900	1000	1100	1200	1300	1400	1500	
# of Rows	2	3	4	5	6	7	8	9	10	11	12	13	14	15	
Spacing (ft)	1.50	1.75	2.50	3.25	4.00	4.75	5.50	6.25	7.00	7.75	8.50	9.25	10.00	10.75	11.50
	1.75	1.88	2.75	3.63	4.50	5.38	6.25	7.13	8.00	8.88	9.75	10.63	11.50	12.38	13.25
	2.00	2.00	3.00	4.00	5.00	6.00	7.00	8.00	9.00	10.00	11.00	12.00	13.00	14.00	15.00
	2.25	2.13	3.25	4.38	5.50	6.63	7.75	8.88	10.00	11.13	12.25	13.38	14.50	15.63	16.75
	2.50	2.25	3.50	4.75	6.00	7.25	8.50	9.75	11.00	12.25	13.50	14.75	16.00	17.25	18.50
	2.75	2.38	3.75	5.13	6.50	7.88	9.25	10.63	12.00	13.38	14.75	16.13	17.50	18.88	20.25
	3.00	2.50	4.00	5.50	7.00	8.50	10.00	11.50	13.00	14.50	16.00	17.50	19.00	20.50	22.00

Pipe Layout Width (Outermost edge of Upper Level to Outermost edge of Lower Level – see illustration on p. 11)

Formula for Multi-Level™ Pipe Layout Width (3 rows or more) = { [Row Spacing x (# of Rows - 1) ] / 2 } + 1. Row spacing is 1.5 ft minimum; larger row spacing is allowed and at the discretion of the designer.

For three level Multi-Level™ Systems contact Technical Support for design criteria

**8.0 Design Procedure and Example**

**Step #1:** From Table A: find the soil's application rate using the percolation rate or soil's texture and calculate the minimum System Sand bed Area (SSBA): divide the daily design flow (GPD) by the application rate.

**Step #2:** From Table A: choose an allowable system slope and bed configuration using the soils percolation rate.

**Step #3:** From Table B: Calculate the minimum amount of Presby Pipe needed: use 3 GPD/ft for residential strength effluent – contact Technical Support for high strength wastewater.

**Step #4:** Calculate the minimum number of serial sections required (does not apply to Parallel configuration): divide the daily design flow by 750 GPD (round up to nearest whole number).

**Step #5:** Select a row length suitable for the site and calculate the number of rows (round up to whole number). The number of rows must be evenly divisible by the number of serial sections required (add rows as necessary).

**Step #6:** Find the Pipe Layout Width (PLW) from (Table C for single level beds) or (Table D for a Multi-Level™ systems) using at a 1.5 ft minimum center-to-center row spacing (larger spacing allowed).

**Step #7:** Calculate the minimum System Sand Bed Width (SSBW) by dividing the System Sand Bed Area from Step #2 by the selected row length from Step #5 + 1ft (allows 6 inches of sand beyond the end of the rows).

**Step #8:** Verify the minimum SSBW from Step #7 will cover all the rows in the bed:

- a) Beds sloping 10% or less: If the minimum SSBW is less than the (PLW + 1 ft), use (PLW + 1 ft) as the new minimum SSBW.
- b) Beds sloping > 10%: If the minimum SSBW is less than the (PLW + 4 ft), use (PLW + 4 ft) as the new minimum SSBW.

**Step #9:** Calculate System Sand Extension(s):

- a) Level beds: System Sand Extension (SSE) are placed on each side of Presby Pipes = [SSBW – (PLW + 1)] ÷ 2. There will be no SSE's if the SSBW = (PLW + 1 ft).
- b) Sloping beds: SSE placed entirely on the down slope side of the bed = SSBW – (PLW + 1). If bed slope is greater than 10%, then the System Sand extension must be a minimum of 3 ft (3.5 ft from the edge of the Presby Pipe).

### 8.1 Design Example (single level)

Single family residence, (3) bedrooms (450 GPD), percolation rate of 10 MPI (sand), 10% sloping site, serial distribution layout, single level.

**Step #1:** Soil's application rate from Table A = 6.74 GPD/ft<sup>2</sup>; SSBA → 450 GPD ÷ 6.74 GPD/ft<sup>2</sup> = 70 ft<sup>2</sup> minimum.

**Step #2:** Table A allows up to 25% system slope for 10 MPI and our system will only slope 10%

**Step #3:** Presby pipe required using 3 GPD/ft from Table B → 450 GPD ÷ 3 GPD/ft = 150 ft minimum

**Step #4:** Serial sections required → 450 GPD ÷ 750 GPD/section = 0.6 (round up to 1)

**Step #5:** Using a row length of 50 ft requires three rows → (150 ft ÷ 50 ft = 3 rows)

**Step #6:** Table C shows a PLW of 4 ft when using 50 ft long rows spaced at 1.5 ft center-to-center.

**Step #7:** Minimum SSBW → 70 ft<sup>2</sup> ÷ (50 ft + 1 ft) = 1.4 ft.

**Step #8:** a) 1.4 ft SSBW is less than 5 ft → (4 ft PLW + 1 ft); use 5 ft as the minimum SSBW. b) Not required.

**Step #9:** a) there are no System Sand extensions → (SSBW = PLW + 1). b) Not required.

Illustration of Example #1, Basic Serial Distribution:

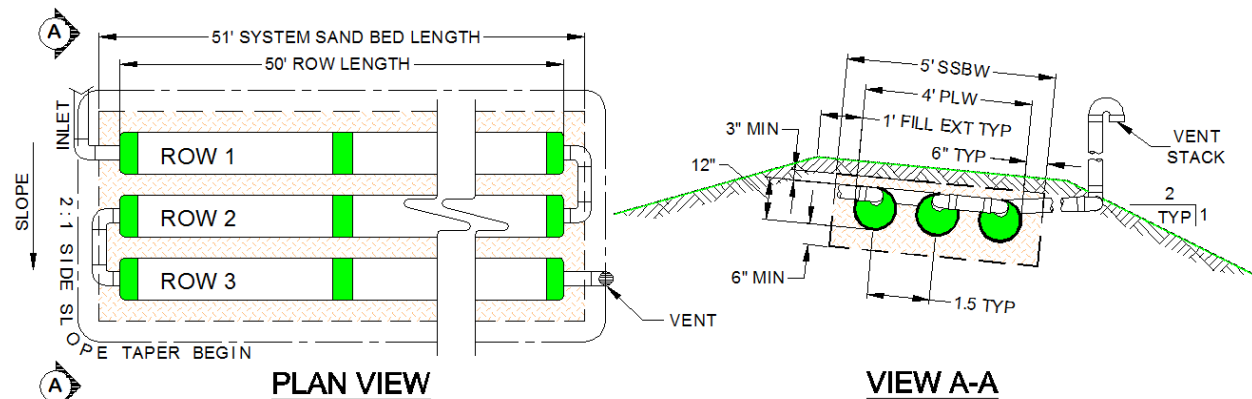

### 9.0 Presby Environmental Standards and Technical Support

All Presby Systems must be designed and installed in compliance with the procedures and specifications described in this Manual and in the product's State approval. This Manual is to be used in conjunction with the State Department of Environmental Health Administrative Rules. In the event of contradictions between this Manual and State regulations, Presby Environmental, Inc. should be contacted for technical assistance at (800) 473-5298. Exceptions to any State rules other than those specifically discussed in this Manual require a State waiver.

#### 10.0 Certification Requirements

Any designers and installers who have not previously attended a Presby Environmental, Inc. Certification Course are strongly encouraged to obtain Presby Certification. Certification is obtained by attending a Certification Course presented by Presby Environmental, Inc. or its sanctioned representative. Certification can also be obtained by viewing tutorial videos on our website (high speed connection required) and then successfully passing a short assessment test, which is also available over the internet. All professionals involved in the inspection, review or certification of AES, ES or SS systems should also become Presby Certified. Professionals involved in the design or installation of Multi-Level™ systems must be Presby Certified.

#### 11.0 Design Criteria

##### 11.1 Advanced Enviro-Septic® Pipe Requirements

- Sewn seam must be oriented in the 12 o'clock position. This correctly orients the Bio-Accelerator® fabric in the 6 o'clock position.
- Venting is always required regardless of vertical separation to restrictive features.
- AES may be substituted for Enviro-Septic® or Simple-Septic®. However, ES or SS may not be substituted for AES without the approval of the designer and Licensed Plumbing Inspector. The design must be revised to show this change.

##### 11.2 Barrier Materials over System Sand

No barrier materials (hay, straw, tarps, etc.) are to be placed between the System Sand and cover material; such materials may cut off necessary oxygen supply to the system. The only exception is the placement of the specified fabric to achieve H-20 loading requirements. See section 26.0, page 17.

##### 11.3 Converging Flows Restriction

Presby Systems must not be located where surface or ground waters will converge, causing surface water flow to become concentrated or restricted within the soil absorption field.

#### 11.4 Daily Design Flow

Residential daily design flow for Presby Systems is calculated in accordance with State rules. Systems servicing more than two residences shall use the Commercial portions of all sizing tables. The minimum daily design flow for any single-family residential system is two bedrooms and 300 GPD for any commercial system.

- a) Certain fixtures, such as jetted tubs, may require an increase in the size of the septic tank.
- b) Daily design flow for a single bedroom apartment with a kitchen connected to a residence (also sometimes referred to as a “studio” or “in-law apartment”) shall be calculated by adding two additional bedrooms.
- c) When daily design flow is determined by water meter for commercial systems, refer to the State Rules.
- d) PEI recommends taking the average daily use from a peak month and multiply it by a peaking factor of 2 to 3 times.
- e) Note that “daily design flows” are calculated to assume occasional “peak” usage and a factor of safety; Systems are not expected to receive continuous dosing at full daily design load.

#### 11.5 End-to-End Preferred Over Side-to-Side

If site conditions permit, End-to-End multiple bed configurations are preferable to Side-to-Side configurations (see para. 20.0, page 15).

#### 11.6 Effluent (Wastewater) Strength

The Presby pipe requirement for Bed or Trench systems is based on residential strength effluent, which has received primary treatment in a septic tank. Residential strength effluent (measured after the septic tank) cannot exceed a concentration of 240 mg/L, when adding together the values for the 5-day biochemical oxygen demand (BOD5) and the total suspended solids (TSS). Typically, this corresponds to an influent strength of 300 mg/L BOD5 and 350 mg/L TSS prior to the septic tank. Designing a system that will treat higher strength wastes requires additional Presby pipe. In these situations, consult our Technical Advisors at (800) 473-5298 for recommendations.

#### 11.7 Fill Extensions for Elevated (Mound) Systems

If any portion of the bed extends above the original grade, the fill covering the field cannot begin the 2:1 side slope taper for a distance of 1 ft minimum from the outmost edge of any Presby Pipe and for systems sloping greater than 10%, the downhill fill extension is increased to 3 ft (remaining three sides have 1 ft).

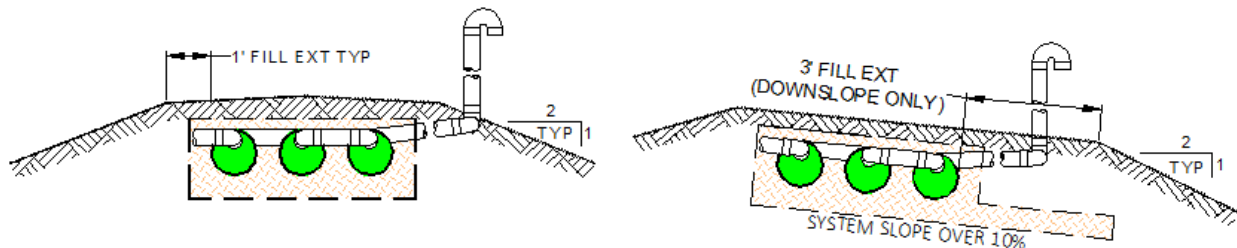

#### 11.8 Filters, Alarms & Baffles

- a) Effluent Filters are **not** recommended for use with Presby Systems.
- b) If used, effluent filters must be maintained on at least an annual basis. Follow manufacturer's instructions regarding required inspections, cleaning and maintenance of the effluent filter. Please consult PEI for the most compatible filter recommendations.
- c) Effluent Filters must allow the free passage of air to ensure the proper functioning of the system. A blocked filter in any on-site septic system could interfere with venting, causing the system to convert to an anaerobic state and result in a shortened life.
- d) All pump systems to have a high water alarm float or sensor installed inside the pump chamber.
- e) All septic tanks must be equipped with baffles to prevent excess solids from entering the Presby System.
- f) Charcoal filters in vent stacks (for odor control) are not recommended by PEI. They can block air flow and potentially shorten system life. Contact PEI for recommendations to correct odor problems.

#### 11.9 Flow Equalizers Required

All distribution boxes used to divide effluent flow require flow equalizers in their outlets. Flow equalizers are limited to a maximum of 15 GPM per equalizer.

#### 11.10 Garbage Disposals (a.k.a. Garbage Grinders)

No additional Presby Pipe is required when using a garbage disposal (grinder). If a garbage disposal is utilized, follow the State's requirements regarding septic tank sizing. Multiple compartment septic tanks or multiple tanks are preferred and should be pumped as needed.

#### 11.11 Presby Pipe Requirement (Single & Multi-Level™)

Advanced Enviro-Septic®, Enviro-Septic® and Simple-Septic® systems all use the same bed sizing tables, pipe and installation requirements noted in this manual with the exception that Simple-Septic® cannot be used in the Multi-

Level™ configuration. See Section 11.1, on page 7 for additional Advanced Enviro-Septic® requirements. Presby Pipe requirements are as follows and require a 1.5 ft minimum row spacing:

- a) Residential systems: 3 GPD/ft assuming effluent strength of 300 mg/L BOD5 and 350 mg/L TSS
- b) Commercial systems: 3 GPD/ft assuming effluent strength of 300 mg/L BOD5 and 350 mg/L TSS
- c) Contact Presby Environmental, Inc. when treating high strength effluent.
- d) Multi-Level™ Systems limited to 30 MPI or faster

### 11.12 Pressure Distribution

The use of pressure distribution lines in Presby Systems is **prohibited**. Pumps may be utilized when necessary only to gain elevation and to feed a distribution box which then distributes effluent by gravity to the Presby Field.

### 11.13 Row Requirements

- a) All beds must have at least 2 rows.
- b) Maximum row length for any system is 100 ft.
- c) Recommended minimum row length is 30 ft.
- d) A combination (or D-Box) distribution system must be used if any row length is less than 30 ft. The D-Box must feed at least 30 ft of Presby Pipe, a minimum of two D-Box outlets must be used and the field must be vented.

Illustration of row lengths less than 30 ft:

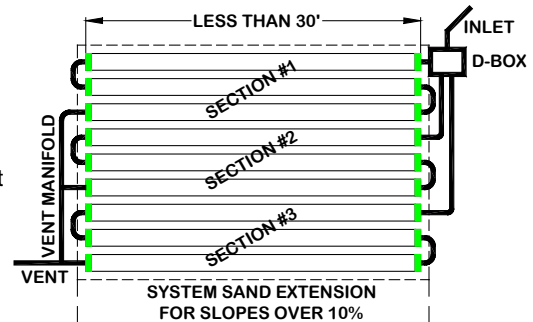

- e) Row Center-to-Center Spacing is 1.5 ft min. for all systems. Row spacing may be increased to accommodate greater basal area spacing requirements if desired.
- f) For level beds: the Presby Rows are centered in the middle of the System Sand bed area and any System Sand extensions divided evenly on both sides.
- g) For Sloping Beds: the elevations for each Presby Row must be provided on the drawing. All rows to be grouped at the high side of the System Sand bed area with any System Sand extensions placed entirely on the downslope side.
- h) All rows must be laid level to within +/- 1/2 in. (total of 1 in.) of the specified elevation and preferably should be parallel to the contour of the site.
- i) It is easier if row lengths are designed in exact 10 ft increments since Presby Pipe comes in 10 ft sections. However, if necessary, the pipe is easily cut to any length to meet site constraints.

### 11.14 System Side Slopes (Side Slope Tapers)

Side slope tapering begins 1 ft from the edge of the Presby Pipe or 3 ft on the downslope side of systems sloping greater than 10% and is to be no steeper than 2:1. There must be at least 12 inches of cover material over the ends of all System Sand extensions (if present). See illustrations in para. 21.0, page 15.

### 11.15 Separation Distances (Horizontal and Vertical)

Separation distances to the seasonal high water table (SHWT) or other restrictive features are measured from the outermost edge of the Presby Pipe.

### 11.16 Sloping Sites and Sloping Mound Systems

- a) The percentage of slope in all system drawings refers to the slope of the Presby System, not the existing terrain ("site slope") and refers to the slope of the bed itself ("system slope").
- b) The system slope and the site slope do not have to be the same (see para. 21.1, page 15).
- c) Maximum site slope is 33% and maximum system slope is 20% (without a State waiver).

### 11.17 System Sand Bed Height Dimension

The height of a Presby Sand Bed measures 21 in. minimum (not including cover material):

- a) 6 in. minimum of System Sand below the Presby Pipe; and
- b) 12 in. diameter of the pipe; and
- c) 3 inches minimum of System Sand above the Presby Pipe.
- d) When a bed slopes over 10%, a minimum 3 ft System Sand Extension area is required and is to be a minimum of 6 in. thick.

### 11.18 Two Inch Rule

The outlet of a septic tank or distribution box must be set at least 2 in. above the highest inlet of the Presby Row, with the connecting pipe slope not less than 1% (approximately 1/8 in. per foot.) Illustration of 2 in. rule:

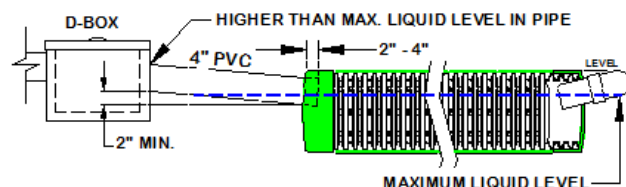

### 11.19 Topographic Position Requirement

The system location must be located in an area that does not concentrate water, both surface and subsurface. If allowed by State and local authorities, altering the terrain upslope of a system may alleviate this requirement if the waters are sufficiently altered to redirect flows away from the field.

### 11.20 Water Purification Systems

- Water purification systems and water softeners should **not** discharge into any Presby System. This “backwash” does not require treatment and the additional flow may overload the system.
- If there is no alternative means of disposing of this backwash other than in the Presby System, then the system will need to be “oversized.” Calculate the total amount of backwash in GPD, multiply by 3, and add this amount to the daily design flow when determining the field and septic tank sizing.
- Water purification systems and water softeners require regular routine maintenance; consult and follow the manufacturer’s maintenance recommendations.

### 12.0 Basic Serial Distribution (Single Level)

AES, ES and SS rows are connected in series at the ends with raised connections, using offset adapters. Basic Serial distribution systems are quick to develop a strong biomat in the first row, provide a longer flow route, improved effluent treatment and ensure air will pass through all the Presby Rows. Other criteria:

- May be used for single beds of 750 GPD or less.
- Basic Serial distribution incorporates rows in serial distribution in a single bed.
- Maximum length of any row is 100 ft.
- Flow Equalizers are not required for Basic Serial systems because they do not divide flow to the bed.
- For level beds: any required System Sand extension is to be evenly divided and placed on both sides of the Presby pipes.
- For sloping beds any required System Sand extension is placed entirely on the downhill (low) side of the field. If the bed slopes over 10%, the System Sand extension must be at least 3 ft.
- Gravity fed Basic Serial systems do not require the use of a D-Box (fed directly from the septic tank).
- Illustrations of Basic Serial Systems:

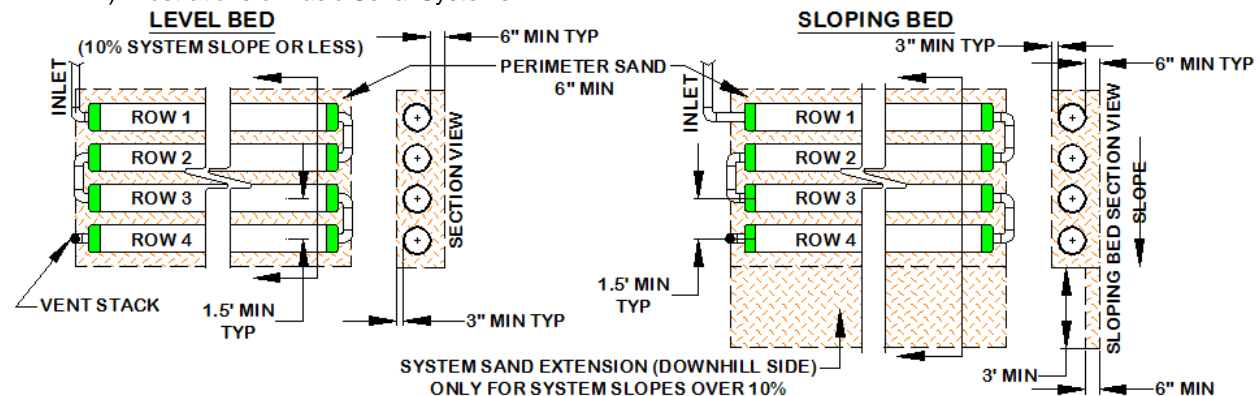
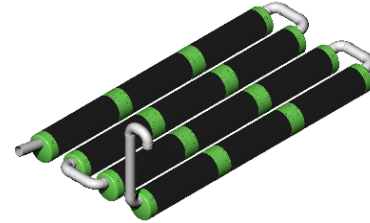

### 13.0 Basic Serial Distribution (Multi-Level™)

Basic Serial Multi-Level™ systems can use Advanced Enviro-Septic® or Enviro-Septic® pipe and must conform to the requirements for single level basic serial systems except:

- Row spacing 1.5 ft minimum.
- All Multi-Level™ beds require venting. The vent must be connected to the last row in the series on the Lower Level.
- Multi-Level™ systems are limited to soils with a percolation rate 30 MPI or less.
- When a System Sand Extension is required, it must be 12 inches thick.
- The 5 ft. offset (fill extension) measured from the Presby Pipe before starting the 3:1 side slope tapers, is measured from the Upper Rows.
- A minimum of 6 in. of System Sand separates the Upper Level Rows from the Lower Level Rows.
- Effluent is delivered first to the Upper Rows, which then connects to the Lower Level Rows by way of a Drop Connection.
- The Drop Connection must pitch downward toward the Lower Level at least 2 inches.
- Multi-Level™ systems are not allowed in H-20 applications.
- For level beds: any required System Sand extension is to be evenly divided and placed on both sides of the Presby pipes.
- For sloping beds any required System Sand extension is placed entirely on the downhill (low) side of the field. If the bed slopes over 10%, the System Sand extension must be at least 3 ft.

l) Illustrations of Multi-Level™ Basic Serial Systems:

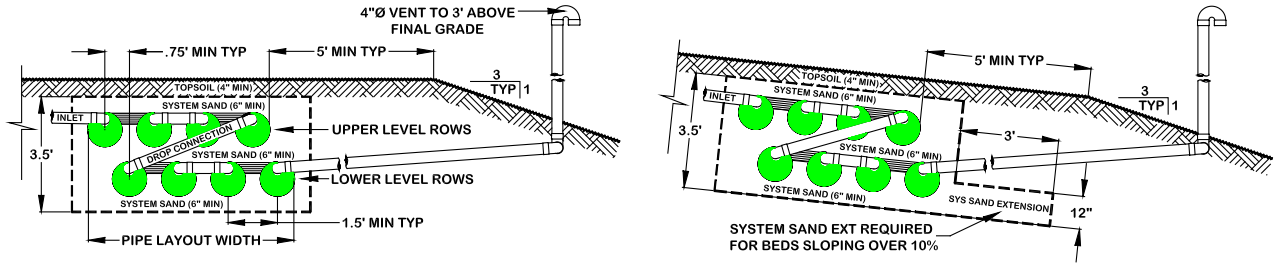

**13.1 Basic Serial Configuration with Unusual Shapes:**

Bed may be constructed with unusual shapes to avoid site obstacles or meet setback requirements.  
Trapezoidal: Parallelogram:



**14.0 Bottom Drain**

A bottom drain is a line connected to the hole in the 6 o'clock position of a double offset adapter at the end of each serial section or each row in a D-box Distribution or Combination Configuration which drains to a sump and is utilized to lower the water level in a saturated system or to facilitate system rejuvenation. There must be 18 inches from the bottom of the sump to the bottom of the drain. The sump should be brought above the final grade and have a locking or mechanically fastened cover.

Illustrations of a bottom drain:

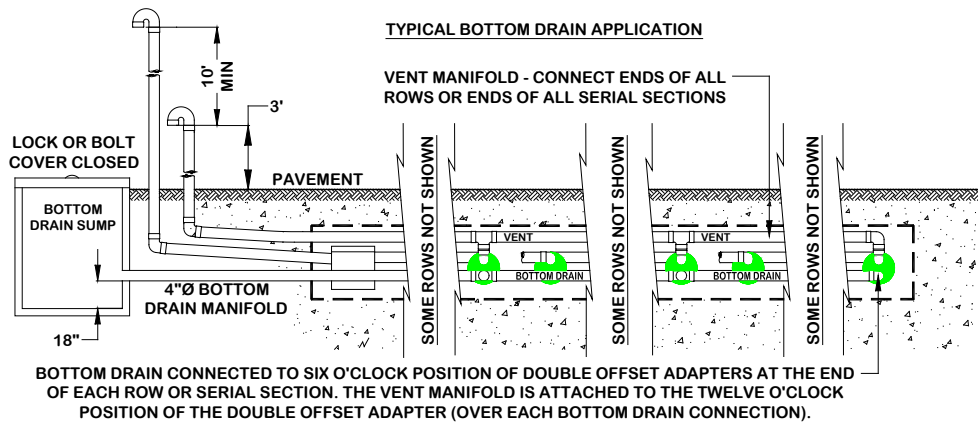
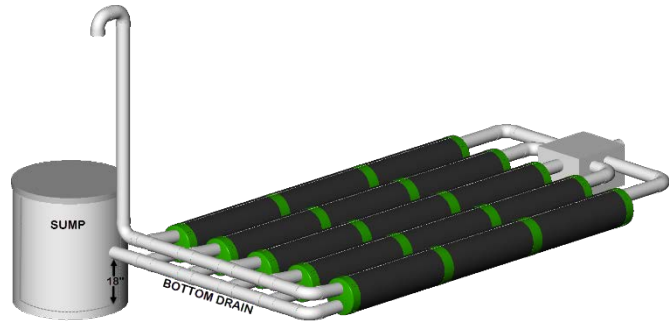

**15.0 Butterfly Configuration**

- a) A "butterfly configuration," is considered a single bed system with two or more sections (can also be D-Box or Combination configurations).
- b) Maximum length of any row is 100 ft.
- c) Serial Section loading limit is 750 GPD.
- d) Beds can contain any number of serial sections.
- e) For level beds: any required System Sand extension is to be evenly divided and placed on both sides of the Presby pipes.

- f) For sloping beds any required System Sand extension is placed entirely on the downhill (low) side of the field. If the bed slopes over 10%, the System Sand extension must be at least 3 ft.
- g) Illustration of a Butterfly configuration:

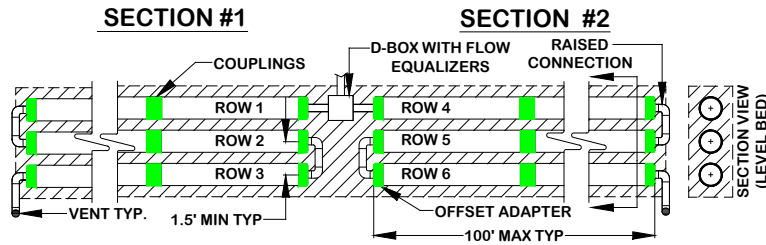

### 16.0 Combination Serial Distribution (Single Level)

Combination Serial distribution within one bed, or multiple beds, is required for systems with daily design flows greater than 750 GPD. Combination Serial distribution is quick to develop a strong biomat in the first row of each section, providing improved effluent treatment. Each Combination Serial section is limited to a maximum loading of 750 gallons/day.

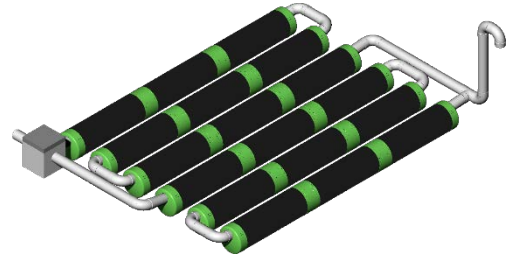

- a) Combination Serial distribution consists of two or more serial sections installed in a single bed.
- b) Each section in a Combination Serial system consists of a series of Presby Rows connected at the ends with raised connections, using offset adapters and PVC sewer and drain pipe.
- c) Maximum length of any row is 100 ft.
- d) Serial Section loading limit is 750 GPD.
- e) There is no limit on the number of Combination Serial Sections within a bed.
- f) For level beds: any required System Sand extension is to be evenly divided and placed on both sides of the Presby pipes.
- g) For sloping beds any required System Sand extension is placed entirely on the downhill (low) side of the field. If the bed slopes over 10%, the System Sand extension must be at least 3 ft.
- h) When the vent manifold is on the same side as the serial section inlets, the manifold runs over the top of these inlets (as shown).
- i) Combination systems require the use of an adequately sized D-Box.
- j) Illustrations of Single Level Combination Serial Systems:

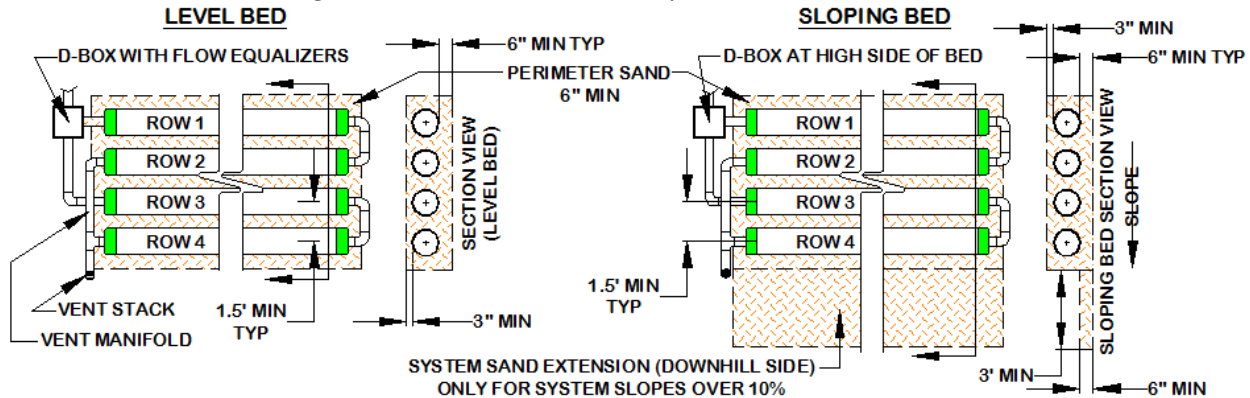

### 16.1 Section Loading

Each section in a Combination Serial system has a maximum daily design flow of 750 GPD. More than the minimum number of sections may be used. Ex: Daily design flow = 1,000 GPD requires  $(1,000 \div 750) = 1.4$ , use 2 sections minimum. Combination systems are only required if the daily design flow exceeds 750 GPD.

### 16.2 Section Length Requirement

- a) Each section must have the same minimum linear feet of pipe.
- b) The minimum linear feet of pipe per section is determined by dividing the total linear feet required in the Presby System by the number of sections required.
- c) A section may exceed the minimum linear feet required.
- d) Rows within a section may vary in length to accommodate site constraints.

### 16.3 Irregular Shaped Combination Serial Configuration

Illustration of Irregular shaped combination system (venting not shown):

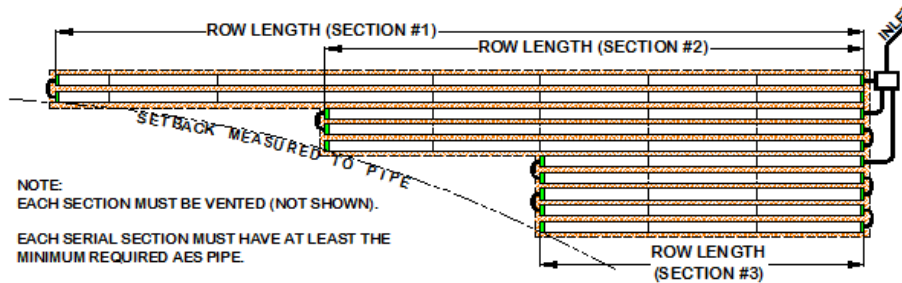

### 17.0 Segmented Row Option

Due to local rules or regulations, linear loading requirements may force trench lengths that would use more Presby pipe than is needed for treatment. In these cases the Presby rows may be divided into smaller segments along the length of the trench. This will provide even distribution across the entire length of the trench without using more pipe than is needed for wastewater treatment.

### 17.1 How to Construct Sections of Presby pipe

Presby pipes are connected with PVC piping using Double Offset Adapters. The lower PVC connector pipe is a conduit for wastewater, and the upper PVC connector pipe is a conduit for air/gases. See illustration below.

### 17.2 Parameters for Segmented Rows

There is considerable flexibility in using this feature depending on the particulars of the design. The intent of this option is to maximize even distribution, so Segmented Rows should be constructed in a balanced manner. Other considerations:

- The maximum length of a PVC connector is 20 ft (segment separation).
- The total length of all segments in a trench must be at least 50% of the sand bed's overall length.
- PVC connectors extend 2 to 4 in. into the Double Offset Adapter. The Double Offset Adapter holes are to be placed at the 12:00 and 6:00 o'clock positions.
- May be used with all methods of distribution (basic serial, combination or parallel distribution)
- Illustration of Segmented rows using serial distribution (no d-box required):

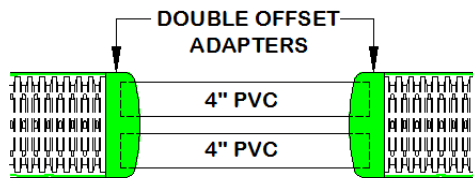
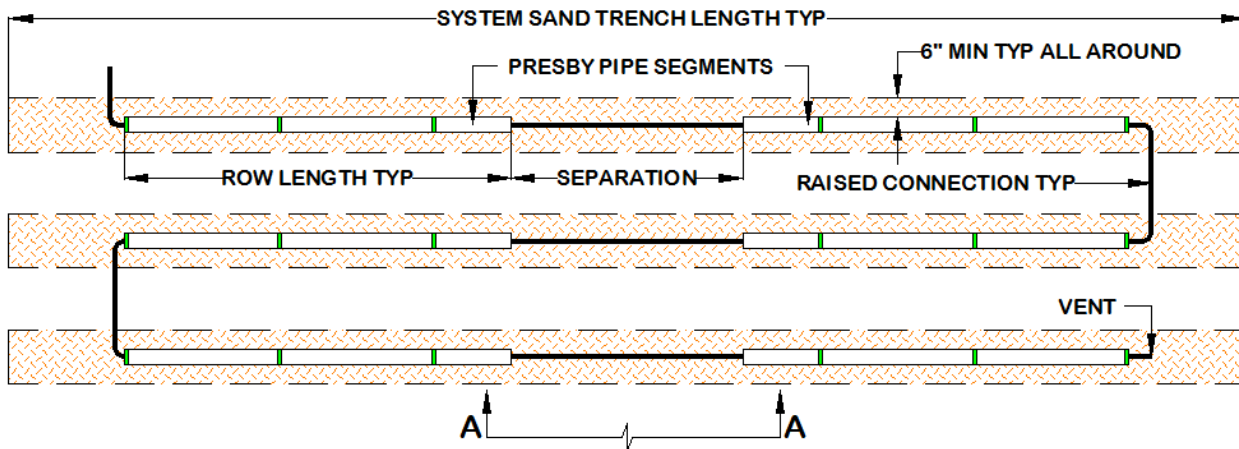

View A-A



- f) Illustration of Segmented row option using Parallel distribution:

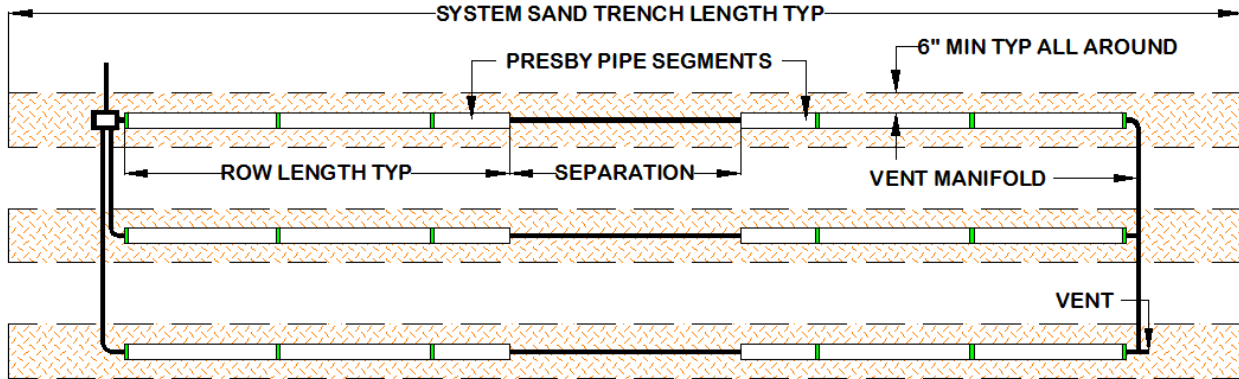

### 18.0 Combination Serial Distribution (Multi-Level™)

Combination Multi-Level™ systems can use Advanced Enviro-Septic® or Enviro-Septic® pipe and must conform to the requirements for single level combination systems except:

- Row spacing 1.5 ft minimum.
- Effluent must be delivered to the Upper Level Rows from the D-Box. A Drop Connection delivers effluent from the Upper Level rows to the Lower Level rows.
- All Multi-Level™ beds require venting. The ends of all serial sections on the Lower Level are manifolded and taken to a vent stack. Each serial section may be vented separately.
- Multi-Level™ systems are limited to soil with a percolation rate of 30 MPI or less.
- If a System Sand Extension is required, it must be 12 in. thick
- The fill extension is measured from the Presby Pipe (measured from the upper level rows) before starting the 4:1 side slope tapers, is measured from the Upper Rows.
- A minimum of 6 in. of System Sand separates the Upper Level Rows from the Lower Level Rows.
- Effluent is delivered first to the Upper Rows, which then connects to the Lower Level Rows by way of a Drop Connection.
- The Drop Connection must pitch downward toward the Lower Level at least 2 in.
- For level beds: any required System Sand extension is to be evenly divided and placed on both sides of the Presby pipes.
- For sloping beds any required System Sand extension is placed entirely on the downhill (low) side of the field. If the bed slopes over 10%, the System Sand extension must be at least 3 ft.
- Illustrations of Multi-Level™ Combination Serial Systems:

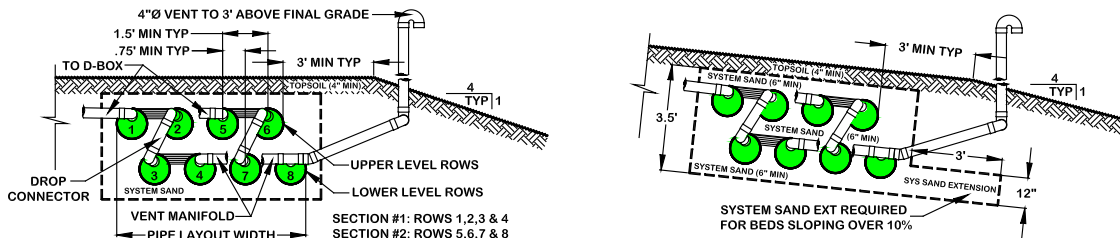

### 19.0 D-Box Distribution (Single Level)

- All rows in this configuration must be the same length.
- Flow equalizers must be used in the D-Box.
- Use a Manifold to connect the ends of all rows. Manifold to be sloped toward Presby Pipes.
- Maximum row length is 100 ft.
- Place the D-box on level, firmly compacted soil.
- All rows must be laid level end-to-end.
- A 2 in. min. drop is required between the D-box outlets and the Presby Pipe inlets.
- D-Box systems are not recommended for use in Multi-Level™ beds.
- For level beds: any required System Sand extension is to be evenly divided and placed on both sides of the Presby pipes.
- For sloping beds any required System Sand extension is placed entirely on the downhill (low) side of the field. If the bed slopes over 10%, the System Sand extension must be at least 3 ft.

h) Illustrations for D-Box (Parallel) Distribution:  
**LEVEL BED**

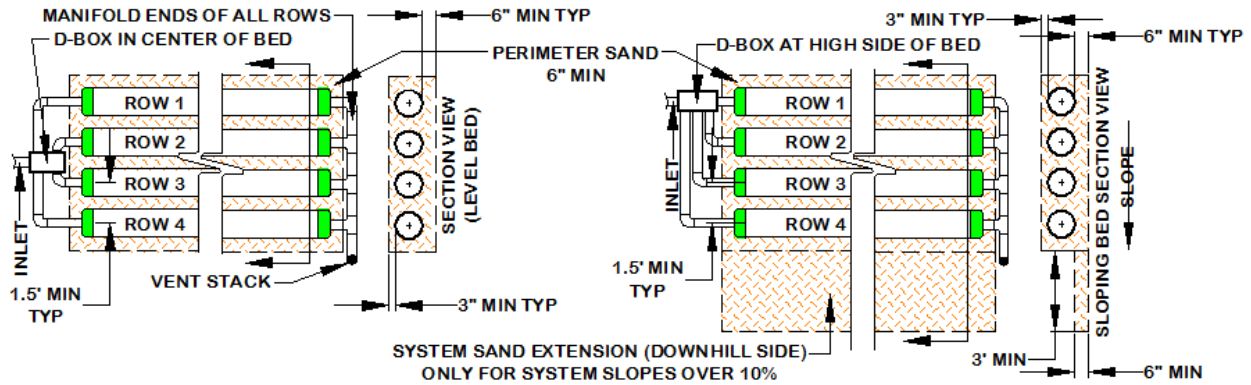

**20.0 Multiple Bed Distribution**

Multiple Bed distribution incorporates two or more beds (Single Level or Multi-Level™), each bed with Basic Serial, Combination Serial, or D-Box distribution, and each receiving an equal amount of effluent from a D-Box. Multiple beds may be oriented along the contour of the site or along the slope of the site.

- Each bed must have the same minimum linear feet of pipe. The minimum linear feet of pipe per bed is determined by dividing the total linear feet required in the Presby System by the number of beds.
- Rows within a bed may vary in length to accommodate site constraints, except with D-Box configuration which requires all rows to be the same length.
- End-to-End configurations are preferred to Side-to-Side configurations.
- In Side-to-Side configuration, one bed is placed beside another or one bed is placed down slope of another. Bed separation distance is measured from pipe-to-pipe and is dependent on soil hydrology and State requirements.
- Multi-Level™ may be used in multiple bed systems.

Illustration of End-to-End Multiple Beds:

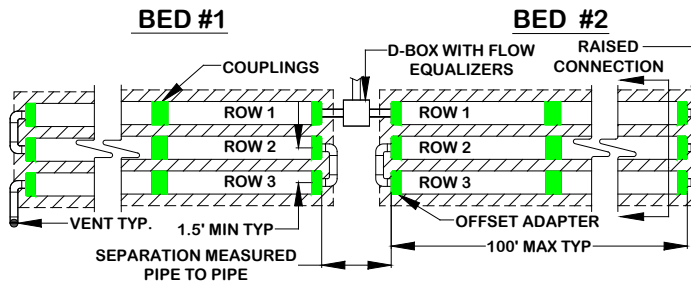
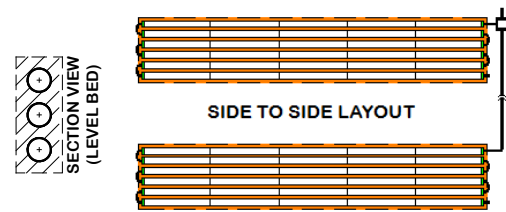
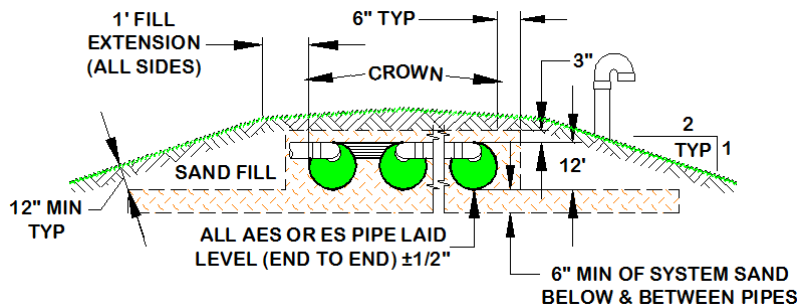

Illustration of Side-to-Side Multiple Beds:



**21.0 Elevated Bed Systems (Mounds)**

Elevated Presby Beds are designed for sites with soil, depth to groundwater or restrictive feature constraints that do not allow for In-Ground Bed Systems. An elevated bed system is a soil absorption field with any part of the Presby System above original grade. Elevated bed systems require 1 ft fill extensions on each side (measured from the pipe), and 5 ft on the downhill side of beds sloping greater than 10%, after which side-slope tapering is to be a maximum of 2 horizontal feet for each 1 foot of vertical drop until it meets existing grade. There must be at least 12 inches of cover material over the ends of all System Sand extensions (if present). Illustration of an elevated level bed:



**21.1 System Sand Extension**

In Systems sloping more than 10%, a 3 ft minimum System Sand extension is required. The System Sand extension area is placed on the down slope side of all sloping systems. The System Sand extension area is a minimum of 6

inches deep (12 inches for Multi-Level™ beds). For multiple slope beds, if any portion of the bed has a system slope greater than 10% a system sand extension is required. Illustration of bed with multiple slopes above.

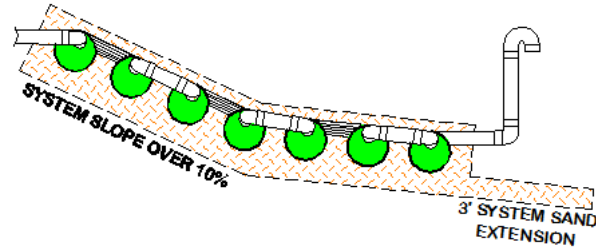

### 21.2 Total Linear Feet Requirement

- Maximum row length is 100 ft.
- Each section or bed must have at least the minimum linear feet of pipe (total feet of pipe required divided by number of sections equals the minimum number of feet required for each section or bed).
- A section or bed may exceed the minimum linear length.
- Rows within a section or bed may vary in length (except D-Box configurations) to accommodate site constraints.

### 22.0 In-Ground Bed Systems

Presby Systems are installed below existing grade for sites with no soil restrictive features to limit placement. In-Ground systems that slope over 10% require a 3 ft system sand extension on the downhill side of the field. In-ground on level site:

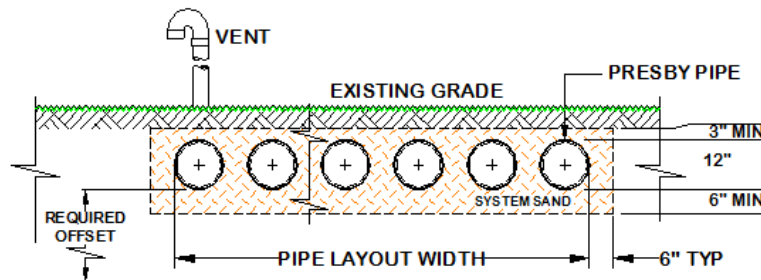

### 23.0 Angled and Curving Beds

Angled configurations are used to avoid obstacles.

- Rows should follow the contour of the site as much as possible
- Rows are angled by bending pipes up to 90 degrees or through the use of offset adapters
- Row lengths are required to be a minimum of 30 ft
- Multi-Level™ systems may take advantage of angled bed configurations.
- Illustrations of Angled Beds:

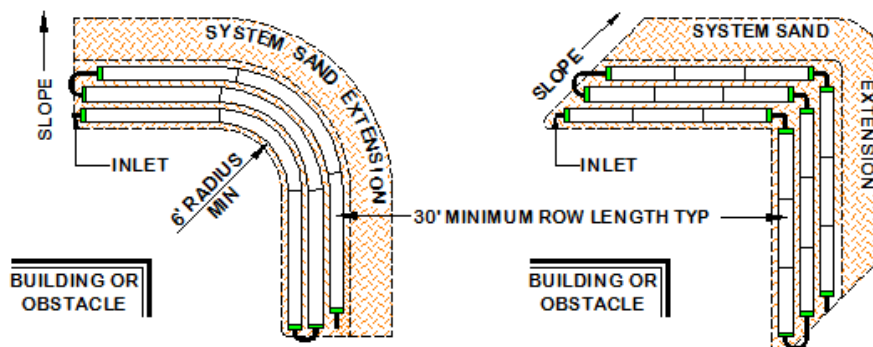

### 23.1 Trench Systems

Presby pipe may be installed in trench configurations on level or sloping terrain and may utilize serial, combination or parallel distribution. Trench systems may incorporate one or two rows of Presby pipe. A minimum of 6 inches of System Sand are required below, above, between and around the perimeter of all Presby pipes. Consult regulatory rules for required trench separation.

### 24.0 Curved Beds

Curved configurations work well around structures, setbacks, and slopes. Multiple curves can be used within a system to accommodate various contours of the site.

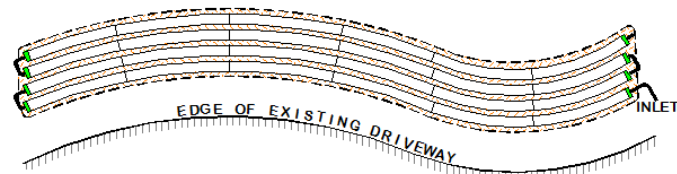

## 25.0 Non-Conventional System Configurations

Non-conventional system configurations may have irregular shapes to accommodate site constraints. A site specific waiver from the state may be required for non-conventional configurations.

## 26.0 H-20 Loading

If a system is to be installed below an area that will be subjected to vehicular traffic, it must be designed and constructed as depicted below in order to protect the system from compaction and/or damage. Note that a layer of stabilization fabric is added between the System Sand and the cover material. All H-20 systems require venting. Illustration of H-20 loading requirements:

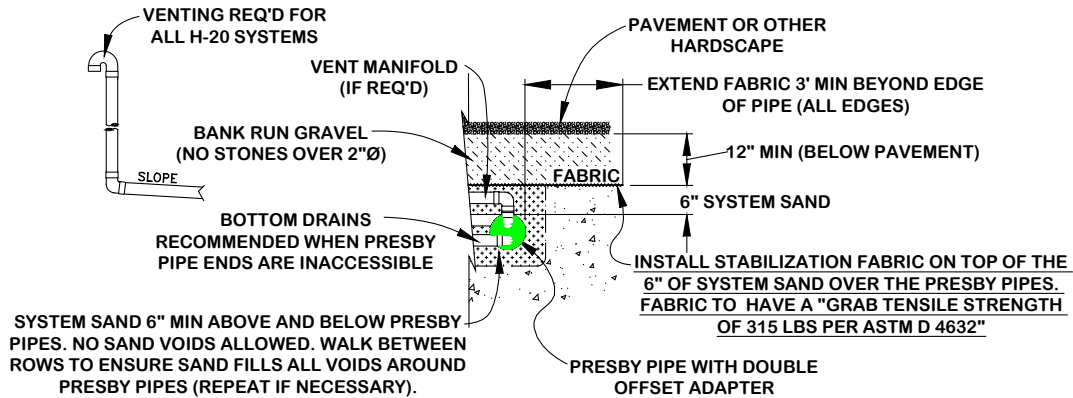

### NOTE:

THE ONLY SOIL COMPACTION THAT SHOULD TAKE PLACE IS AT THE POINT OF PREPARATION FOR PAVEMENT.

## 27.0 Pumped System Requirements

Pumped systems supply effluent to the Presby System using a pump and distribution box when site conditions do not allow for a gravity system. Dosing siphons are also an acceptable means of delivering effluent to the system.

### 27.1 Alarm

States require all pump systems to have a high water alarm float or sensor installed inside the pump chamber.

### 27.2 Differential Venting

All pump systems must use differential venting (see illustration, para. 29.4, page19).

### 27.3 Distribution Box

All pump systems require a distribution box with some means of velocity reduction for the effluent entering the D-Box.

### 27.4 Velocity Reduction

The rate at which effluent enters the Presby Pipe must be controlled. Excessive effluent velocity can disrupt solids that settle in the pipes.

- Effluent must never be pumped directly into Presby Pipe.
- A distribution box or tank must be installed between the pumping chamber and the Presby Pipe to reduce effluent velocity.
- Force mains must discharge into a distribution box (or equivalent) with velocity reducer and a baffle, 90° bend, tee or equivalent (see illustrations on next page).

Two methods of velocity reduction:

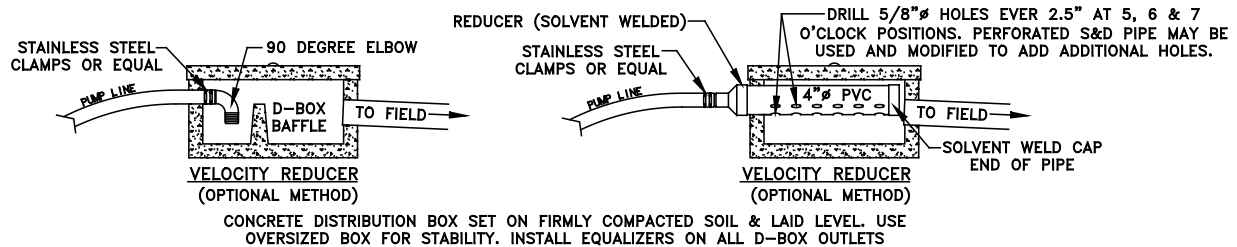

### 27.5 Dose Volume

- Pump volume per dose must be no greater than 1 gallon times the total linear feet of Presby Pipe.
- Pump dosing should be designed for a minimum of 6 cycles per day.
- If possible, the dosing cycle should provide one hour of drying time between doses.

### 27.6 Basic Serial Distribution Limit

Pumped systems with Basic Serial distribution are limited to a maximum dose rate of 40 gallons per minute and do not require the use of a flow equalizer on the D-Box outlet. Never pump directly into Presby Pipe.

### 27.7 Combination and Multiple-Bed Distribution Limit

All Presby Systems with Combination Serial distribution or Multiple Bed distribution must use Flow Equalizers in each distribution box outlet. Each Bed or section of Combination Serial distribution is limited to a maximum of 15 gallons per minute, due to the flow constraints of the equalizers. Example: pumping to a combination system with 3 sections (using 3 D-Box outlets). The maximum delivery rate is  $(3 \times 15) = 45$  GPM. Always provide a means of velocity reduction.

### 28.0 System Sand and Sand Fill Requirements for All Beds

It is critical to the proper functioning of Presby System's that the proper amount and type of System Sand be installed.

### 28.1 Quantity of System Sand

System Sand is placed a minimum of 6 in. below, above and between the Presby Rows and a minimum of 6 in. horizontally around the perimeter of the Advanced Enviro-Septic®, Enviro-Septic® and Simple-Septic® rows.

### 28.2 Sand Fill

Sand fill meeting state and local requirements is used to raise the elevation of the system in order to meet the required separation distance from the SHWT or other restrictive feature. No organic material or stones larger than 6 in. are allowed in the Sand Fill. System Sand may be used in place of sand fill; however, this may increase material costs.

### 29.0 Venting Requirements

An adequate air supply is essential to the proper functioning of Presby Systems. Venting is always required. Including the following requirements:

- a) Pump systems must utilize Differential Venting.
- b) Vents for Multi-Level™ beds must connect to the lower level rows.

### 29.1 General Rules

- a) Vent openings must be located to ensure the unobstructed flow of air through the entire Presby System.
- b) The low vent inlet must be a minimum of 1 ft above final grade or anticipated snow level.
- c) One 4 in. vent is required for every 1,000 ft of Presby Pipe.
- d) A single 6 in. vent may be installed in place of up to three 4 in. vents.
- e) If a vent manifold is used, it must be at least the same diameter as the vent(s).
- f) When venting multiple beds, it is preferred that each bed be vented separately rather than manifolding bed vents together.
- g) Sch. 40 PVC or equivalent should be used for all vent stacks.
- h) Remote Venting may be utilized to minimize the visibility of vent stacks.

### 29.2 Differential Venting

- a) Differential venting is the use of high and low vents in a system.
- b) In a gravity system, the roof stack acts as the high vent.
- c) High and low vent openings must be separated by a minimum of 10 vertical feet.
- d) If possible, the high and low vents should be of the same capacity.

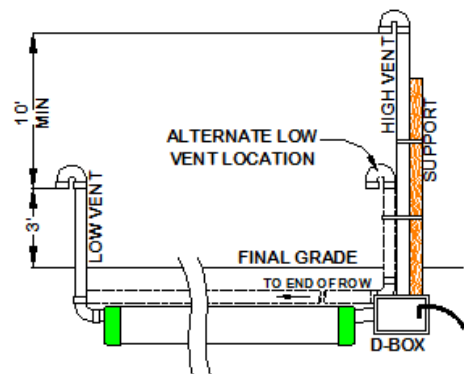

### 29.3 Vent Locations for Gravity Systems

- a) A low vent is installed at the end of the last row of each section or the end of the last row in a Basic Serial bed, or at the end of each row in a D-Box Distribution Configuration system. A vent manifold may be used to connect the ends of multiple sections or rows.
- b) The house (roof) vent functions as the high vent as long as there are no restrictions or other vents between the low vent and the house (roof) vent.
- c) When the house (roof) vent functions as the high vent, there must be a minimum of a 10 ft vertical differential between the low and high (roof) vent openings.

d) Illustration of gravity system air flow:

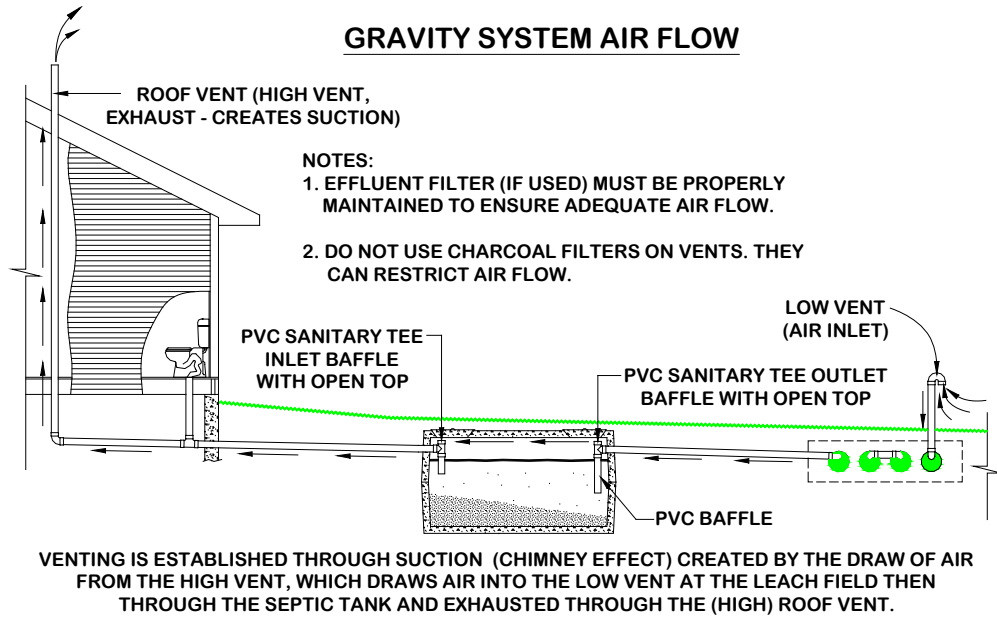

#### 29.4 Pump System Vent Locations

- A low vent is installed through an offset adapter at the end of each section, Basic Serial bed or attached to a vent manifold.
- A high vent is attached to an unused distribution box outlet.
- A 10 ft minimum vertical differential is required between high and low vent openings.
- When venting multiple beds, it is preferred that each bed be vented separately (have their own high and low vents) rather than manifolding bed vents together.
- The Low and High vents may be swapped provided the distribution box is insulated against freezing in cold climates.
- See Remote Venting (para. 29.7, page 20) and Bypass Venting (para. 29.8, page 20) for options to relocate or eliminate the High Vent.

#### 29.5 Vent Manifolds

A vent manifold may be incorporated to connect the ends of a number of sections or rows of Presby Pipe to a single vent opening. Slope the lines connecting the manifold to the Presby pipes to drain condensation. See diagrams below:

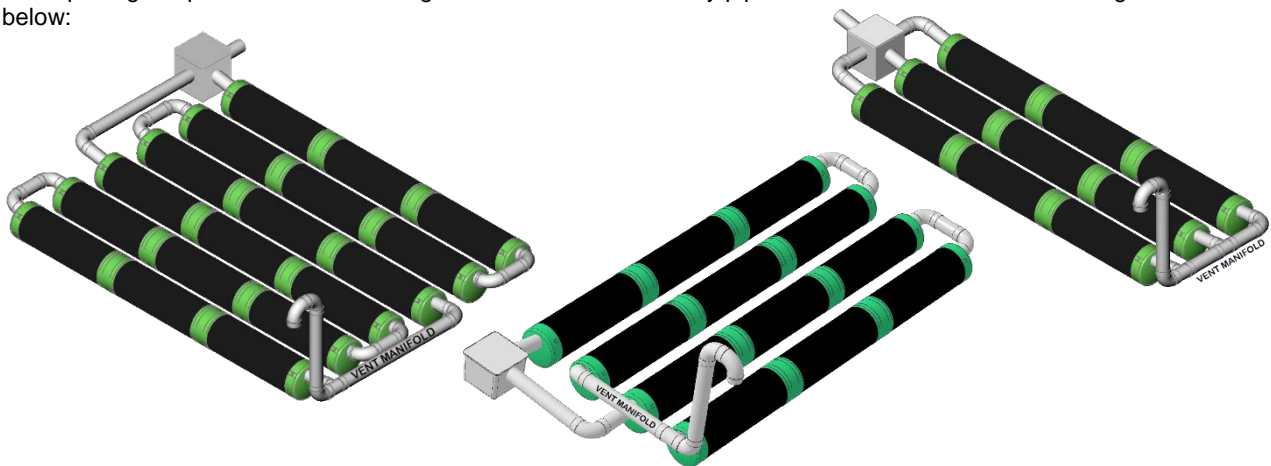

#### 29.6 Vent Piping Slope

Vent piping should slope downward toward the system to prevent moisture from collecting in the pipe and blocking the passage of air.

### 29.7 Remote Venting

If site conditions do not allow the vent pipe to slope toward the system, or the owner chooses to utilize remote venting for aesthetic reasons (causing the vent pipe not to slope toward the system), the low point of the vent line must be drilled creating several 1/4 in. holes to allow drainage of condensation. This procedure may only be used if the vent pipe connecting to the system has:

- a) A **high point** that is above the highest point of all Presby Pipes or the Distribution Box; and,
- b) A **low point** opened for drainage which is above the SHWT. (See diagram below.)

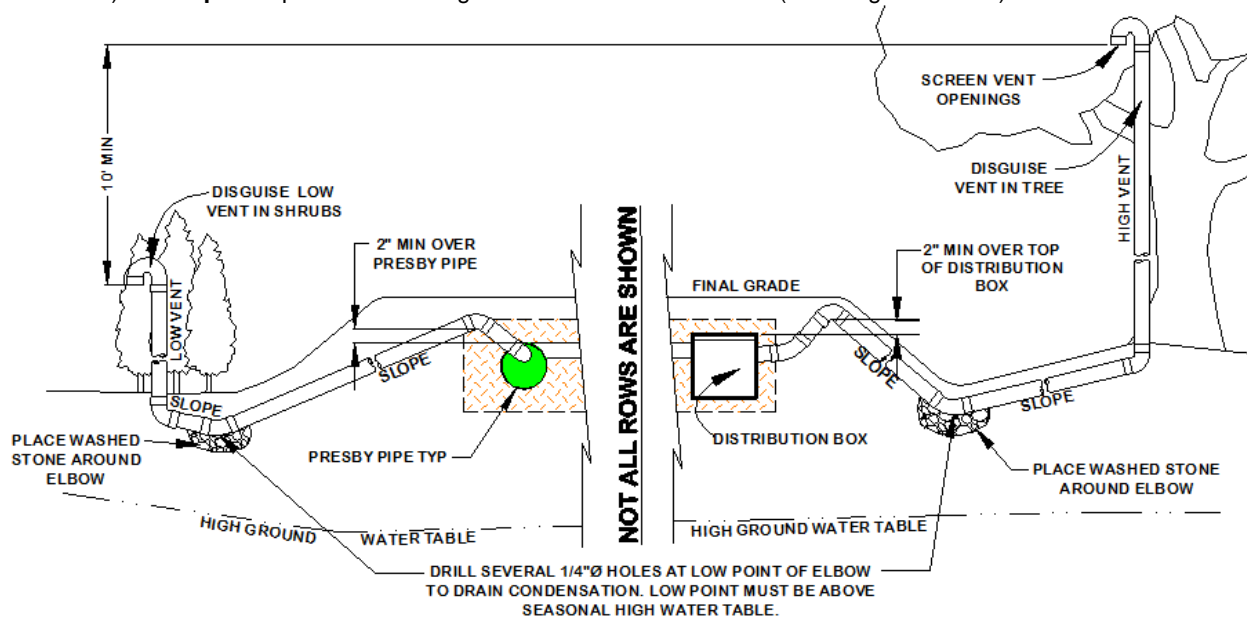

### 29.8 By-Pass Venting

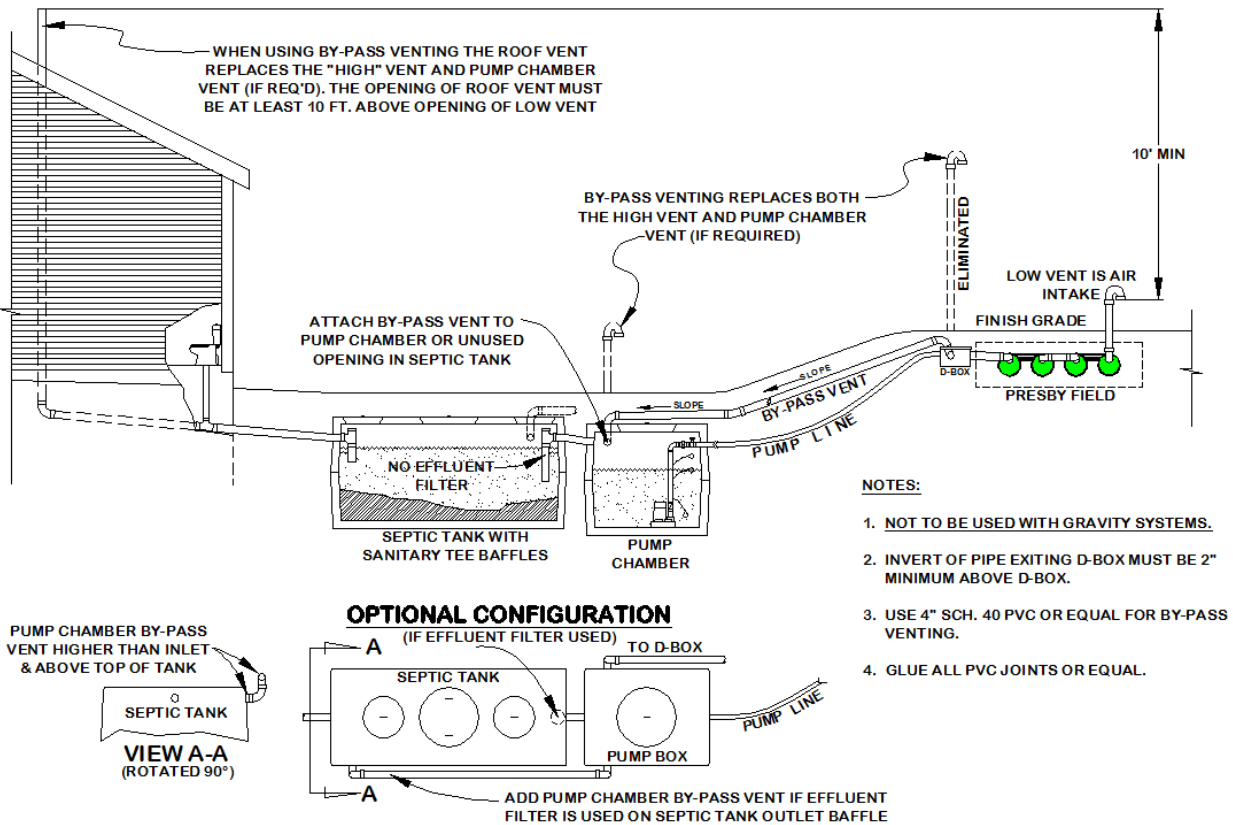

## **30.0 Site Selection**

### **30.1 Determining Site Suitability**

Refer to State or local rules regarding site suitability requirements.

### **30.2 Topography**

Locate systems on convex, hill, slope or level locations that do not concentrate surface flows. Avoid swales, low areas, or toe-of-slope areas that may not provide sufficient drainage away from the system.

### **30.3 Surface Water Diversions**

Surface water runoff must be diverted away from the system. Diversions must be provided up-slope of the system and designed to avoid ponding. Systems must not be located in areas where surface or groundwater flows are concentrated.

### **30.4 Containment**

Systems should not be located where structures such as curbs, walls or foundations might adversely restrict the soil's ability to transport water away from the system.

### **30.5 Hydraulic loading**

Systems should not be located where lawn irrigation, roof drains, or natural flows increase water loading to the soils around the system.

### **30.6 Access**

Systems should be located to allow access for septic tank maintenance and to at least one end of all Presby Rows. Planning for future access will facilitate rejuvenation in the unlikely event the system malfunctions.

### **30.7 Rocky or Wooded Areas**

Avoid locating systems in rocky or wooded areas that require additional site work, since this may alter the soil's ability to accept water. No trees or shrubs should be located within 10 ft of the system to prevent root infiltration.

### **30.8 Replacement System**

In the event of system malfunction, contact PEI for technical assistance prior to attempting Rejuvenation procedures.

In the unlikely event that a Presby System needs to be replaced ...

- a) It can be reinstalled in the same location, eliminating the need for a replacement field reserve area.
- b) All unsuitable material must be removed prior to replacement system construction.
- c) Disposal of hazardous materials to be in accordance with State and local requirements.
- d) Permits may be required for system replacement; contact the appropriate local or state agency.

## **31.0 Installation Requirements, Component Handling and Site Preparation**

### **31.1 Component Handling**

- a) Keep mud, grease, oil, etc. away from all components.
- b) Avoid dragging pipe through wet or muddy areas.
- c) Store pipe on high and dry areas to prevent surface water and soil from entering the pipes or contaminating the fabric prior to installation.
- d) The outer fabric of the Presby Pipe is ultra-violet stabilized; however, this protection breaks down after a period of time in direct sunlight. To prevent damage to the fabric, cover the pipe with an opaque tarp if stored outdoors.

### **31.2 Critical Reminder to Prevent Soil Compaction**

It is critical to keep excavators, backhoes, and other equipment off the excavated or tilled surface of a bed. Before installing the System Sand, excavation equipment should be operated around the bed perimeter; not on the bed itself.

### **31.3 Site Preparation Prior to Excavation**

- a) Locate and stake out the System Sand bed, extension areas and soil material cover extensions on the site according to the approved plan.
- b) Install sediment/erosion control barriers prior to beginning excavation to protect the system from surface water flows during construction.
- c) Do not travel across or locate excavation equipment within the portion of the site receiving System Sand.
- d) Do not stockpile materials or equipment within the portion of the site receiving System Sand.
- e) It is especially important to avoid using construction equipment down slope of the system to prevent soil compaction.

### **31.4 When to Excavate**

- a) Do not work wet or frozen soils. If a fragment of soil from about 9 in. below the surface can easily be rolled into a wire, the soil moisture content is too high for construction.



- b) Do not excavate the system area immediately after, during or before precipitation.

### 31.5 Tree Stumps

Remove all tree stumps and the central root system below grade by using a backhoe or excavator with a mechanical “thumb” or similar extrication equipment, lifting or leveraging stump in a manner that minimizes soil disturbance.

- a) Do not locate equipment within the limits of the System Sand bed.
- b) Avoid soil disturbance, relocation, or compaction.
- c) Avoid mechanical leveling or tamping of dislodged soil.
- d) Fill all voids created by stump or root removal with System Sand.

### 31.6 Organic Material Removal

Before tilling, remove all grass, leaves, sticks, brush and other organic matter or debris from the excavated system site. It is not necessary for the soil of the system site to be smooth when the site is prepared.

### 31.7 Raking and Tilling Procedures

All areas receiving System Sand, sand fill and fill extensions **must** be raked or tilled. If a backhoe/excavator is used to till the site, fit it with chisel teeth and till the site. The backhoe/excavator must remain outside of the proposed System Sand area and extensions.

- a) For in-ground bed systems, excavate the system bed as necessary below original grade. Using an excavator or backhoe, tilt the bucket teeth perpendicular to the bed and use the teeth to rake furrows 2 in.- 6 in. deep into the bottom of the entire area receiving System Sand or sand fill (“receiving area”).
- b) For elevated bed systems remove the “A” horizon, then use an excavator or backhoe to rake furrows 2 in. – 6 in. deep into the receiving area.

### 31.8 Install System Sand and/or Sand Fill Immediately After Excavation

- a) To protect the tilled area (System Sand bed area and System Sand extension area) from damage by precipitation, System Sand should be installed immediately after tilling.
- b) Work off either end or the uphill side of the system to avoid compacting soil.
- c) Keep at least 6 in. of sand between the vehicle tracks and the tilled soil of the site if equipment must work on receiving soil.
- d) Track construction equipment should not travel over the installed system area until at least 12 in. of cover material is placed over the Presby Pipes.
- e) Heavy equipment with tires must never enter the receiving area due to likely wheel compaction of underlying soil structures.

### 31.9 Distribution Box Installation

To prevent movement, be sure D-boxes are placed level on compacted soil, sand, pea gravel base, or concrete pad.

### 31.10 Level Row Tolerances

Use a laser level or transit to install rows level. Variations beyond 1 in. ( $\pm 1/2$ " ) may affect system performance and are not acceptable.

### 31.11 Correct Alignment of Advanced Enviro-Septic® Bio-Accelerator® Fabric

The Bio-Accelerator® (white geo-textile fabric) is to be positioned centered along the bottom of the pipe rows (sewn seam up).

### 31.12 Row Spacers

System Sand may be used to keep pipe in place while covering, but simple tools may also be constructed for this purpose. Two examples are shown. One is made from rebar, the other from wood. Center-to-center row spacing may be larger than specified by this manual. **Caution:** Remove all tools used as row spacers before final covering.

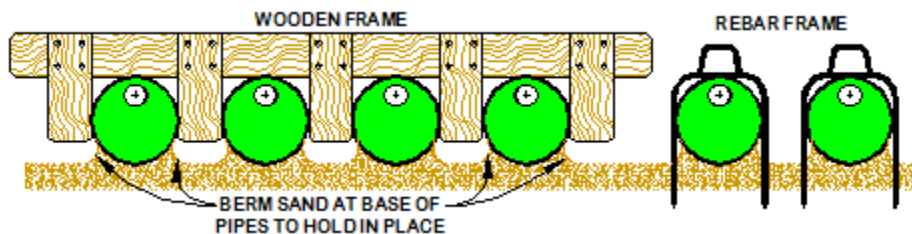

### 31.13 Connect Rows Using Raised Connections

Raised connections consist of offset adapters, 4 in. PVC sewer and drain pipe, and 90° elbows. They enable greater liquid storage capacity and increase the bacterial surfaces being developed. Use raised connections to connect the rows of the Presby System (see para. 3.5, page 3 ). Glue or mechanically fasten all pipe connections.

### **31.14 Backfilling Rows**

- a) Spread System Sand between the rows.
- b) If using AES, confirm pipe rows are positioned with Bio-Accelerator® along the bottom (sewn seam up).
- c) Straddle each row of pipe and walk heel-to-toe its entire length, ensuring that System Sand fills all void spaces beneath the Presby Pipe.
- d) Finish spreading System Sand to the top of the rows and leave them exposed for inspection purposes.

### **31.15 Backfilling and Final Grading**

Spread System Sand to a minimum of 3 inches over the pipe and a minimum of 6 inches beyond Presby Pipes on all four sides beyond the Presby Pipes. Spread soil material free of organics, stones over 4 inches and building debris, having a texture similar to the soil at the site, without causing compaction. Construction equipment should not travel over the installed system area until at least 12 inches of cover material is placed over the Presby Pipes (H-10 Loading). 18 inches of cover material over the Presby System is required for H-20 loading (see para. 26.0, page 17).

### **31.16 Fill Extensions Requirements**

All Presby Systems with any portion of the System Sand bed above original grade require 1 ft fill extensions on each side beyond the outside edge of all Presby Pipes (3 ft on downhill side of systems sloping greater than 10%) and then tapering to meet existing grade at a maximum slope of 2:1 (see illustration in para. 21.0 page 15).

### **31.17 System Soil Cover Material**

A minimum of 4 inches of suitable earth cover (topsoil or loam), with a texture similar to the soil at the site and capable of sustaining plant growth, must be placed above the installed system.

### **31.18 Erosion Control**

To prevent erosion, soil cover above the system shall be planted with native, shallow-rooted vegetation such as grass, wildflowers and certain perennials or ground covers.

### **31.19 Trees and Shrubs**

It is recommended that no trees or shrubs be located within 10 ft of the system perimeter to prevent roots from growing into and damaging the system.

## **32.0 System Bacteria Rejuvenation and Expansion**

This section covers procedures for bacteria rejuvenation and explains how to expand existing systems.

**Note:** Presby Environmental, Inc. must be contacted for technical assistance prior to attempting rejuvenation procedures.

### **32.1 Why would System Bacteria Rejuvenation be needed?**

Bacteria rejuvenation is the return of bacteria to an aerobic state. Flooding, improper venting, alteration or improper depth of soil material cover, use of incorrect sand, sudden use changes, introduction of chemicals or medicines, and a variety of other conditions can contribute to converting bacteria in any system from an aerobic to an anaerobic state. This conversion severely limits the bacteria's ability to effectively treat effluent, as well as limiting liquids from passing through. A unique feature of the Presby System is its ability to be rejuvenated in place.

### **32.2 How to Rejuvenate System Bacteria**

System bacteria are "rejuvenated" when they return to an aerobic state. By using the following procedure, this can be accomplished in most Presby Systems without costly removal and replacement.

1. Contact Presby Environmental before attempting Rejuvenation for technical assistance.
2. Determine and rectify the problem(s) causing the bacteria conversion.
3. Drain the system by excavating one end of all the rows and removing the offset adapters.
4. If foreign matter has entered the system, flush the pipes.
5. Safeguard the open excavation.
6. Guarantee a passage of air through the system.
7. Allow all rows to dry for 72 hours minimum. The System Sand should return to its natural color.
8. Re-assemble the system to its original design configuration. As long as there is no physical damage to the Presby components, the original components may be reused.

## **33.0 System Expansion**

Presby Systems are easily expanded by adding equal lengths of pipe to each row of the original design or by adding additional equal sections. All system expansions must comply with State and local regulations. Permits may be required prior to system expansion.

### **33.1 Reusable Components**

Presby Pipe and components are not biodegradable and may be reused. In cases of improper installation it may be possible to excavate, clean, and reinstall all system components.

## **34.0 Operation & Maintenance**

### **34.1 Proper Use**

Presby Systems require minimal maintenance, provided the system is not subjected to abuse. An awareness of proper use and routine maintenance will guarantee system longevity. We encourage all system owners and service providers to obtain and review a copy of our Owner's Manual, available from our website [www.PresbyEnvironmental.com](http://www.PresbyEnvironmental.com) or via mail upon request to (800) 473-5298 or [info@presbyeco.com](mailto:info@presbyeco.com).

### **34.2 System Abuse Conditions**

The following conditions constitute system abuse:

- a) Liquid in high volume (excessive number of occupants and use of water in a short period of time, leaking fixtures, whirlpool tubs, hot tubs, water softening equipment or additional water discharging fixtures if not specified in system design).
- b) Solids in high volume (excessive number of occupants, paper products, personal hygiene products, garbage disposals or water softening equipment if not specified in system design)
- c) Antibiotics and medicines in high concentrations
- d) Cleaning products in high concentrations
- e) Fertilizers or other caustic chemicals in any amount
- f) Petroleum products in any amount
- g) Latex and oil paints
- h) System suffocation (compacted soils, barrier materials, etc.) without proper venting

Note: PEI and most regulatory agencies do not recommend the use of septic system additives.

### **34.3 System Maintenance/Pumping of the Septic Tank**

- a) Inspect the septic tank at least once every two years under normal usage.
- b) Pump the tank when surface scum and bottom sludge occupy one-fourth or more of the liquid depth of the tank.
- c) If a garbage disposal is used, the septic tank will likely require more frequent pumping.
- d) After pumping, inspect the septic tank for integrity to ensure that no groundwater is entering it. Also check the integrity of the tank inlet and outlet baffles and repair if needed.
- e) Inspect the system to ensure that vents are in place and free of obstructions.
- f) Effluent filters require ongoing maintenance due to their tendency to clog and cut off oxygen to the System. Follow filter manufacturer's maintenance instructions and inspect filters frequently.

### **34.4 Site Maintenance**

It is important that the system site remain free of shrubs, trees, and other woody vegetation, including the entire System Sand bed area, and areas impacted by side slope tapering and perimeter drains (if used). Roots can infiltrate and cause damage or clogging of system components. If a perimeter drain is used, it is important to make sure that the outfall pipes are screened to prevent animal activity. Also check outfall pipes regularly to ensure that they are not obstructed in any way.

## **35.0 Glossary**

This Manual contains terminology which is common to the industry and terms that are unique to Presby Systems. While alternative definitions may exist, this section defines how these terms are used in this Manual.

### **35.1 Bio-Accelerator®**

Bio-Accelerator® fabric screens additional solids from the effluent, enhances and accelerates treatment, facilitates quick start-up after periods of non-use, provides additional surface area for bacterial growth, promotes even distribution, and further protects outer layers and the receiving surfaces so they remain permeable. Bio-Accelerator® is only available with Advanced Enviro-Septic®.

### **35.2 Advanced Enviro-Septic® (AES) Pipe**

A single unit comprised of corrugated plastic pipe, Bio-Accelerator® fabric along its bottom which is surrounded by a layer of randomized plastic fibers and a sewn geo-textile fabric, is 10 ft in length, with an outside diameter of 12 in. and a storage capacity of approximately 58 gallons. Each foot of Advanced Enviro-Septic® provides over 40 sq ft of total surface area for bacterial activity. The sewn seam is always oriented up (12 o'clock position) within the bed. A white tag is sewn into the seam indicating the product is Advanced Enviro-Septic® pipe. Pipes are joined together with couplings to form rows. Advanced Enviro-Septic® is a combined wastewater treatment and dispersal system.

### **35.3 Drop Connection (Multi-Level™ Systems)**

A drop connection is a PVC Sewer & Drain pipe configuration which is used to connect upper level rows to lower level rows in a Multi-Level™ bed. Drop connections extend 2 in. to 4 in. into the pipe and are installed with at least 2 in. of drop from the upper level row to the lower level row. All PVC joints should be glued or mechanically fastened.

#### **35.4 Enviro-Septic® (ES) Pipe**

A single unit comprised of corrugated plastic pipe which is surrounded by a layer of randomized plastic fibers and a sewn geo-textile fabric, is 10 ft in length, with an outside diameter of 12 in. and a storage capacity of approximately 58 gallons. Each foot of Enviro-Septic® provides over 25 sq ft of total surface area for bacterial activity. A white tag is sewn into the seam indicating the product is Enviro-Septic® pipe. Pipes are joined together with couplings to form the rows. Enviro-Septic® is a combined wastewater treatment and dispersal system.

#### **35.5 Simple-Septic® (SS) Pipe**

A single unit comprised of corrugated plastic pipe which is surrounded by a single layer of sewn geo-textile fabric, is 10 ft in length, with an outside diameter of 12 in. and a storage capacity of approximately 58 gallons. Each foot of Simple-Septic® provides over 15 sq ft of total surface area for bacterial activity. A white tag is sewn into the seam indicating the product is Simple-Septic® pipe. Pipes are joined together with couplings to form rows.

#### **35.6 Basic Serial Distribution**

Basic Serial distribution incorporates Presby Rows in serial distribution in a single bed (see Basic Serial Distribution in para. 12.0, page 10).

#### **35.7 Bottom Drain**

A bottom drain is a line connected to the hole in the 6 o'clock position of a double offset adapter at the end of each serial section or each row in a D-Box Distribution Configuration which drains to a sump and is utilized to lower the water level in a saturated system or to facilitate system rejuvenation (see illustration in para. 14.0, page 11).

#### **35.8 Butterfly Configuration**

A variation of a standard, single bed system with the D-box located in the center, with rows oriented symmetrically on either side, and with each side or section receiving an equal volume of flow from the D-Box. See Butterfly Configuration (see para. 15.0, page 11).

#### **35.9 Center-to-Center Row Spacing**

The distance from the center of one Presby Row to the center of the adjacent row.

#### **35.10 Coarse Randomized Fiber**

A mat of coarse, randomly-oriented fibers (AES & ES only) which separates more suspended solids from the effluent protecting the bacterial surface in the geo-textile fabric (see illustration in para. 2.0, page 2).

#### **35.11 Combination Serial Distribution**

Incorporates two or more sections of Presby Pipe in a single bed, with each section receiving a maximum of 750 GPD of effluent from a distribution box. Combination Distribution is not required for daily flows of 750 GPD or less. See Combination Serial Distribution, para. 16.0, on page 12.

#### **35.12 Cooling Ridges**

Pipe ridges that allow the effluent to flow uninterrupted around the circumference of the pipe and aid in cooling (see illustration in para. 2.0, page 2).

#### **35.13 Coupling**

A plastic fitting that joins two Presby Pipe pieces in order to form rows (see para.3.4, page 3).

#### **35.14 Daily Design Flow**

The peak daily flow of wastewater to a system, expressed in gallons per day (GPD); systems are typically sized based on the daily design flow. Design flow calculations are set forth in the State Rules. In general, actual daily use is expected to be one-half to two-thirds less than "daily design flow."

#### **35.15 Differential Venting**

A method of venting a Presby System utilizing high and low vents (see para. 29.2, page 18).

#### **35.16 Distribution Box or "D-Box"**

A device designed to divide and distribute effluent from the septic tank equally to each of the outlet pipes that carry effluent into the Presby System. D-Boxes are also used for velocity reduction, see Velocity Reduction, para. 27.4, page 17.

#### **35.17 D-Box Distribution Configuration**

A design in which each Presby Row receives effluent from a distribution box outlet. Such a system is also called a "parallel system" or a "finger system." See D-Box (Parallel) Distribution, para. 19.0, page 14.

#### **35.18 End-to-End Configuration**

Consists of two or more beds constructed in a line (i.e., aligned along the width of the beds). See para. 20.0, page 15 and illustration on page 14.

### **35.19 Fill Extension**

Utilized in constructing Elevated (mound) Systems and blend the raised portion of the system with side slope tapering to meet existing grade. In systems sloping up to 10%, the fill extensions extend 3 ft on all sides. In systems sloping more than 10%, the fill extension is increased to 5 ft on the down slope side (see para. 21.0, page 15).

### **35.20 Flow Equalizer**

An adjustable plastic insert installed in the outlet pipes of a D-Box to equalize effluent distribution to each outlet.

### **35.21 GPD and GPM**

An acronym for Gallons per Day and Gallons per Minute respectively.

### **35.22 High and Low Vents**

Pipes used in differential venting. Detailed information about venting requirements can be found in Venting Requirements, para. 29.0, page 18.

### **35.23 High Strength Effluent**

High strength wastewater is septic tank effluent quality with combined 30-day average carbonaceous biochemical oxygen demand (BOD5) and total suspended solids (TSS) in excess of two-hundred and forty (240) mg/L.

### **35.24 Manifolded Splitter Box**

A PVC configuration which connects several distribution box outlets together in order to equalize effluent flow. Refer to drawing in para. 3.7, on page 3.

### **35.25 MPI**

An acronym for Minutes per Inch and is the numerical value by which percolation rates (also called "perc rates") are expressed.

### **35.26 Multi-Level™**

A Multi-Level™ System is a patented process using Presby Pipe; it consists of essentially two Presby Systems installed in the same bed with one system on top of another with 6 in. of System Sand between the two levels. Multi-Level Systems are approved for use in soils with a percolation rate of 30 MPI or less and may use Advanced Enviro-Septic® or Enviro-Septic® pipe.

### **35.27 Multiple Bed Distribution**

Incorporates two or more beds, each bed with Basic Serial, Combination Serial, or D-Box distribution and receiving effluent from a distribution box (see para. 20.0, page 15).

### **35.28 Non-Conventional Configurations**

Have irregular shapes or row lengths shorter than 30 ft to accommodate site constraints (see para. 13.1, page 11).

### **35.29 Offset Adapter**

A plastic fitting with a 4 in. hole installed at the 12 o'clock position which allows for connections from one row to another and for installation of venting (see para. 3.2, page 3).

### **35.30 Percolation Rate**

Also known as Perc Rate, is a numerical indication of a soil's hydraulic capacity, expressed in minutes per inch (MPI.)

### **35.31 Pressure Distribution**

A pressurized, small-diameter pipe system used to deliver effluent to an absorption field. Pressure Distribution is not permitted to be used with the Presby System. Presby Systems are designed to promote even distribution without the need for pressure distribution.

### **35.32 Pump Systems**

Utilize a pump to gain elevation in order to deliver effluent to a D-Box (see para. 27.0, page 17).

### **35.33 Raised Connection**

A U-shaped, 4" diameter, PVC pipe configuration which is used to connect rows oriented in a serial configuration and to maintain the proper liquid level inside each row. See drawing in para. 3.5, page 3.

### **35.34 Raking and Tilling**

Refers to methods of preparing the native soil that will be covered with System Sand or Sand Fill, creating a transitional layer between the sand and the soil. See Installation Requirements para. 31.7, page 22.

### **35.35 Row**

Consists of a number of Presby Pipe sections connected by couplings with an Offset Adapter on the inlet end and an Offset Adapter or End Cap on the opposite end. Rows are typically between 30 ft and 100 ft long (see Row Requirements in para. 11.13, page 9).

### **35.36 Sand Fill**

Clean sand, free of organic materials and meeting the specifications set forth in Sand Fill, para. 28.2, page 18. Sand fill is used to raise the elevation of the system to meet required separation distance or in side slope tapers. System Sand may be used in place of Sand Fill.

### **35.37 Section / Serial Section**

A group of interconnected rows receiving effluent from one distribution box outlet. Sections are limited to 750 GPD daily design flow maximum.

### **35.38 Serial Distribution**

Two or more Presby Rows connected by a Raised Connection. Basic Serial distribution is described in detail in sections 12.0 and 13.0, on page 10. Combination Serial distribution is described in detail in paragraphs 16.0 and 17.0, pages 12 and 13.

### **35.39 Skimmer Tabs**

Projections into the AES, ES and SS pipe that help to capture grease and suspended solids from the existing effluent (see illustration in para. 2.0, page 2).

### **35.40 Side-to-Side Configuration**

Consist of two or more beds arranged so that the rows are parallel to one another (See para. 20.0, page 15 and illustration on page 14).

### **35.41 Slope (3:1)**

In this Manual's illustrations, slope is expressed as a ratio of run to rise. Example: A slope with a grade of (2:1) is the difference in horizontal distance of three (2) horizontal feet (run) over an elevation difference of one (1) ft (rise).

### **35.42 Slope (%)**

Expressed as a **percent**, is the difference in elevation divided by the difference in horizontal distance between two points on the surface of a landform. Example: A site slope of one (1) percent is the difference in elevation of one (1) foot (rise) over a horizontal distance of one hundred (100) feet (run).

### **35.43 Smearing**

The mechanical sealing of soil air spaces along an excavated, tilled or compressed surface. This is also referred to as "compacting." In all installations, it is critical to avoid smearing or compacting the soils under and around the field.

### **35.44 Surface Diversion**

A natural or manmade barrier that changes the course of water flow around an onsite system's soil absorption field.

### **35.45 System Sand Bed**

System Sand area required/used in Presby Systems. The System Sand bed extends a minimum of 6 in. below, 6 in. above and 6 in. horizontally from the outside edges of the Presby Pipes.

### **35.46 System Sand**

System Sand must be clean, granular sand free of organic matter and must adhere to the Presby System Specification with no more than 3% passing the #200 sieve (see complete details in para. 28.0, page 18).

### **35.47 System Sand Extension Area**

The System Sand extension area is a minimum of 6 in. deep for Single Level systems and 12 in. deep for Multi-Level systems. The System Sand extension is placed on the down slope side of sloping systems. System sloping more than 10% require a 3 ft minimum extension. The System Sand extension is measured from the tall portion of the System Sand bed (see illustration in para. 21.1, page 15).

### **35.48 Topsoil (a.k.a. Loam or Soil Cover Material)**

Topsoil, also known as Loam, is soil material cover capable of sustaining plant growth which forms the topmost layer of cover material above the system.

### **35.49 Velocity Reducer**

Velocity reducer refers to any of the various components whose purpose is to reduce the velocity of effluent flow into the Presby Pipes. A distribution box with a baffle or inlet tee is sufficient for velocity reduction in most systems (see illustration in para. 27.4, page 17).