

Advanced Enviro-Septic®(AES) Treatment System

Delaware

Design and Installation Manual



Made in USA

✓ Minimizes the Expense ✓ Protects the Environment ✓ Preserves the Site



Presby Environmental, Inc.
The Next Generation of Wastewater Treatment Technology

143 Airport Rd., Whitefield, NH 03598

Tel: 800-473-5298 Fax: (603) 837-9864

Email: info@presbyeco.com

www.PresbyEnvironmental.com

The information in this manual is subject to change without notice. We make a continual effort to improve our Manuals in order to ensure they are as complete, accurate and helpful as possible. Please confirm that this is the most recent and up-to-date version of this Manual by contacting us at (800) 473-5298 or visiting our website, www.presbyenvironmental.com

Your questions, suggestions and comments are welcome. Please contact us at:

Presby Environmental, Inc.
143 Airport Road
Whitefield, NH 03598
Phone: 1-800-473-5298 Fax: (603) 837-9864
Website: www.PresbyEnvironmental.com

24 April 2012 MSM

IMPORTANT NOTICE: This Manual is intended ONLY for use in designing and installing Presby Environmental's Advanced Enviro-Septic® Wastewater Treatment System.

The use of this Manual with any other product is prohibited.

The processes and design criteria contained herein are based solely on our experience with and testing of Advanced Enviro-Septic®.

Substitution of any other large diameter gravelless pipe will result in compromised treatment of wastewater and other adverse effects.

This Manual sets forth the Manufacturer's recommendations and requirements; designers and installers are responsible for determining and complying with applicable state and/or local regulations.

Advanced Enviro-Septic® U.S. Patent Nos. 6,461,078; 5,954,451; 5,606,786; 6,899,359; 6,792,977 and 7,270,532 with other patents pending.

Canadian Patent Nos. 2,300,535; 2,185,087; 2,187,126 with other patents pending.

Multi-Level™ Advanced Enviro-Septic® U.S. Patent No. 6,290,429 with other patents pending.

Enviro-Septic® is a registered trademark of Presby Environmental Inc.

Advanced Enviro-Septic® is a registered trademark of Presby Environmental, Inc.



State of Delaware
Department of Natural Resources & Environmental Control
Division of Water Resources
Ground Water Discharges Section

Innovative and Alternative System Approval

ISSUED TO: Presby Environmental
143 Airport Rd.
Whitefield, NH 03598

Phone 1-800-473-5298
Fax (603) 837-9864
www.presbyenvironmental.com

FROM: Jason Baumgartner – Environmental Scientist
Ground Water Discharges Section

FOR: Advanced Enviro-Septic® Treatment System

APPROVAL DATE: April 24, 2012

In accordance with the Regulations Governing the Design, Installation, and Operation of On-Site Wastewater Treatment and Disposal Systems (Regulations), an application dated October 10, 2009 has been submitted by Presby Environmental for the approval of the Advanced Enviro-Septic® Treatment System as an Innovative & Alternative On-Site Wastewater Treatment Unit and Disposal System.

Based on the information submitted, the Department approves the use of the Advanced Enviro-Septic® Treatment System as an Innovative & Alternative On-Site Wastewater Treatment Unit and Disposal System. The following conditions, limitations, and requirements must be adhered to:

1. Product Description

Advanced Enviro-Septic® (“AES”) is an innovative onsite wastewater treatment system that is passive, non-mechanical and does not use pressure distribution. The primary component is a large diameter perforated, multi-layer fabric-wrapped pipe that is installed in a bed of specified System Sand. The Advanced Enviro-Septic® System is designed to purify

wastewater that has received primary treatment in a septic tank and to disperse the treated wastewater into the underlying soils.

The AES uses a combined biological process. The system utilizes both suspended growth and attached growth processes for treatment of the wastewater. Suspended growth is achieved in the wastewater as it is distributed through the rows of pipes. Attached growth is achieved through the three layers of geotextiles surrounding the pipes and the first millimeters of sand around the pipes.

2. Approved Advanced Enviro-Septic® Systems

The AES must utilize gravity distribution and follow the d-box configuration as shown in the manufacturer's design and installation manual for Delaware.

3. Scope of Use

The system may be used for residential, community and commercial applications with flows < 2,500 gallons per day. Use for flows >2,500 gallons per day shall be reviewed on a case by case basis.

4. Siting Criteria

- a. Percolation rates are to be based on the most restrictive texture within the upper 60" of soil. See the attached chart for loading rate associated with a percolation rate.
- b. Landscape position is also a necessary consideration. Systems are not to be sited within a closed depression or where water tends to pond during heavy rainfall events.
- c. The system cannot be installed on slopes >2%.

5. Separation Requirements

- a. A 36" separation distance must be maintained from the bottom of the pipe to the limiting condition (LZ).
- b. Full depth installation = 60" or greater to LZ.
- c. Capping Fill installation = 48-59" to LZ.

6. Design Criteria

- a. The AES system may be designed for new and replacement disposal systems.
- b. A septic tank shall precede the AES system. The septic tank must incorporate an effluent filter.
- c. An on-site wastewater treatment and disposal system permit application incorporating an AES system must be designed in accordance with the Regulations and manufacturer's specifications. The design shall be completed by a DNREC licensed Class C Design Engineer. The permit application shall include: system specifications, disposal field layout, and calculations.
- d. The system bed size shall be determining using the equation given for seepage bed systems in the Regulations with an additional 25% bed size reduction.

- e. The amount of AES pipe required shall be determined using the manufacturer's guidelines.
- f. The System Sand that surrounds the AES pipes is an essential component of the system. It is critical that the correct type and amount of System Sand is used when constructing the system. System Sand must be coarse to very coarse, clean, granular sand, free of organic matter. It must adhere to all of the percentage and quality restrictions as given in the AES design and installation manual.
- g. A sample unit must be included with the design.
- h. No additional area reductions shall be granted for the use of water saving fixtures.

7. Installation Procedures

- a. The AES system shall be installed by a DNREC licensed Class E System Contractor under the supervision of a manufacturer's representative, or by a DNREC Class E System Contractor who has been certified for installation. Proof of certification shall be provided in writing to the Department.
- b. Start up of the system and initial operational checks shall be conducted by the Class E System Contractor (trained by the manufacturer), Design Engineer, and a Ground Water Discharges Section (Large System Branch) representative. If the Class E System Contractor is not certified, a manufacturer's representative shall perform the operational checks of the system at start up. If the manufacturer's representative cannot be on site at the time of start up, they must provide final start up approval to the Department in writing.

8. Operation and Maintenance

- a. The AES system shall be operated and maintained in accordance with the manufacturer's specifications.
- b. The manufacturer shall comply with all Department mandated requirements as specified in permit conditions. This shall include operation and maintenance requirements.

9. Sampling and Approval

The Department reserves the right to sample any system at any time.

10. General Conditions

- a. The manufacturer is responsible for providing the Department a list of all local distributors and their associated contact information. This list must be kept current and shall be submitted to the Department on a yearly basis.
- b. In the event that the product fails to perform as claimed by the applicant, the use of the unit for new installations shall cease. Use of the unit shall not resume until such time the applicant and the Department have reached an acceptable agreement for resolving the situations.
- c. Any changes that deviate from the specifications as submitted with this approval shall be approved by the Department prior to use.
- d. Use of the system for wastes other than residential shall be on a case by case basis.

Table of Contents

	<u>Pages</u>
Section A, Introduction	1-4
Section B, Components	5-7
Section C, System Sizing, AES Pipe Requirements & Design Example	8-9
Section D, System Configurations	10-14
Section E, Design Criteria for Delaware	15-20
Section F, Venting Requirements	21-22
Section G, Site Selection	23
Section H, System Sand & Fill Material Specifications	24
Section I, Preparing for Installation	25-26
Section J, Installation & Construction Procedures	27-29
Section K, Final Grading	30-31
Section L, Operation & Maintenance	32
Section M, Rejuvenation & Expansion of AES Systems	33

**Advanced Enviro-Septic® Treatment System
Delaware Design and Installation Manual**

Section A, Introduction

**What is
Advanced
Enviro-
Septic™?**

Advanced Enviro-Septic® (“AES”) is an innovative onsite wastewater treatment system that is passive, non-mechanical and does not use pressure distribution. The primary component is a large diameter perforated, multi-layer fabric-wrapped pipe that is installed in a bed of specified System Sand. The Advanced Enviro-Septic® System is designed to purify wastewater that has received primary treatment in a septic tank and to disperse the treated wastewater into the underlying soils. The system is extremely versatile and can be designed in a variety of shapes and sizes, making it adaptable to virtually any residential or commercial application. The amount of pipe required and the size of the System Sand bed adjust in relation to the amount of daily design flow, the soil’s characteristics and site constraints, ensuring effective treatment and adequate absorption into underlying soils.

**How Does
Advanced
Enviro-Septic®
work?**

By utilizing simple yet effective natural processes, the Advanced Enviro-Septic® Treatment System treats septic tank effluent in a manner that prevents suspended solids from sealing the underlying soil, increases system aeration, and provides a greater bacterial area (“biomat”) than conventional septic systems.

**Why is
Advanced
Enviro-Septic®
Better?**

The Advanced Enviro-Septic® Treatment System retains solids in its pipe and provides multiple bacterial surfaces to treat effluent prior to its release into the soil. The continual cycling of effluent (the rising and falling of liquid inside the pipe) enhances bacterial activity. No other passive wastewater treatment system design offers this functionality. Our systems excel because they are more efficient, last longer, and have a minimal environmental impact.

**System
Advantages**

- Provides superior treatment
 - Thoroughly tested to prove it works
 - Preserves the natural terrain
 - Cost-effective to construct and operate
 - Completely passive, requires no mechanical devices or electricity
 - Design versatility to adapt to virtually any site, any flow, any application
 - Quicker and easier to install
 - Enhanced function and longevity
 - Requires no special maintenance
 - Superior track record of reliability
 - Made using recycled plastic
-

Introduction, continued

Purpose

The purpose of this Manual is to provide general information regarding the design criteria, installation procedures and use and care instructions for the Advanced Enviro-Septic® Treatment System.

The Advanced Enviro-Septic® System is extremely versatile and, as a result, this Manual cannot possibly set forth every conceivable system configuration. We encourage you to contact our Technical Advisors, who will be happy to address any questions or concerns unique to your project or assist you in designing a system for special applications.

Presby Environmental Standards

All systems using the Advanced Enviro-Septic Treatment™ System must be designed and installed in compliance with the procedures and specifications described in this Manual. Exceptions to any requirements in this Manual require Presby Environmental, Inc. (PEI) approval.

Conflicts Between Delaware Rules & this Manual

In the event of contradictions between this Manual and Delaware and/or local rules, PEI should be contacted for technical assistance.

Certification Required

PEI requires all designers and installers to be certified. Certification is obtained by completing the "Advanced Enviro-Septic® Certification Course" presented by PEI or its sanctioned representative. We offer a variety of certification training options, including online presentations, live training sessions and DVDs. Please visit our website, www.PresbyEnvironmental.com.

Special note: PEI highly recommends that all individuals involved in the approval, permitting or inspection process also complete a certification course.

Technical Support

PEI provides technical support free of charge to all individuals using our products or involved in the permitting process. For any questions about our products or the information contained in this Manual, please contact us at (800) 473-5298, send an email to info@presbyeco.com or visit our website, www.PresbyEnvironmental.com.

Disclaimer

The technical support staff at Presby Environmental, Inc. is committed to providing comprehensive product information and support via telephone, website and email at no cost to our customers. The assistance we are able to provide in this way is based on limited information and therefore should be considered general in nature. Accordingly, Presby Environmental, Inc. disclaims any liability whatsoever in connection with providing technical support.

ADVANCED ENVIRO-SEPTIC™ WASTEWATER TREATMENT SYSTEM

WITH BIO-ACCELERATOR™

TEN STEPS OF WASTEWATER TREATMENT: ADVANCED ENVIRO-SEPTIC™
TREATS EFFLUENT MORE EFFICIENTLY TO PROVIDE LONGER SYSTEM LIFE
AND TO PROTECT THE ENVIRONMENT.

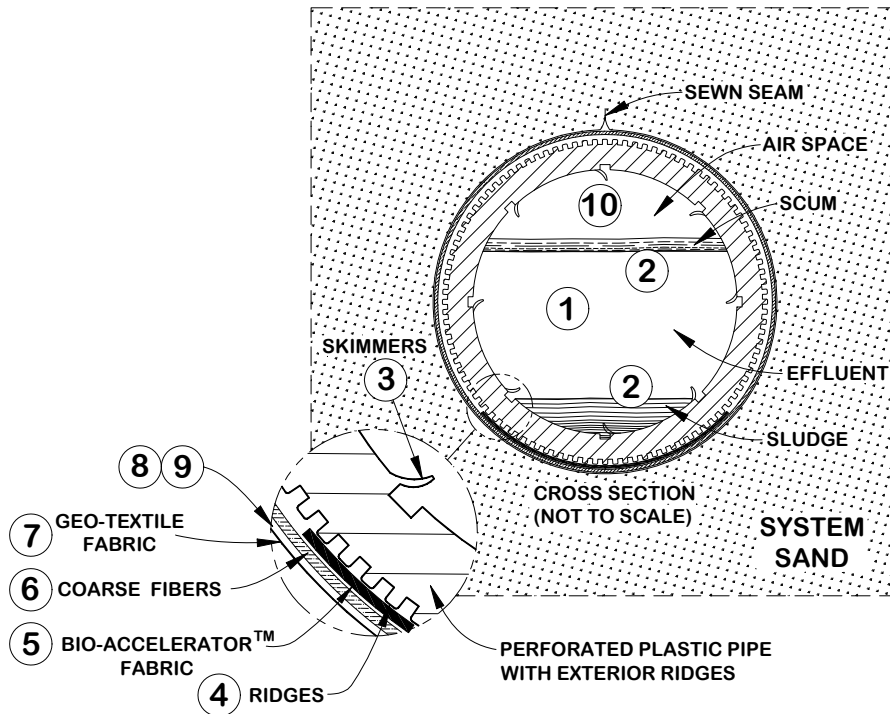

Stage 1	Warm effluent enters the pipe and is cooled to ground temperature.
Stage 2	Suspended solids separate from the cooled liquid effluent.
Stage 3	Skimmers further capture grease and suspended solids from the existing effluent.
Stage 4	Pipe ridges allow the effluent to flow uninterrupted around the circumference of the pipe and aid in cooling.
Stage 5	Bio-Accelerator™ geo-textile fabric filters additional solids from the effluent, enhances and accelerates treatment, facilitates quick start-up after periods of non-use, provides additional surface area for bacterial growth, promotes even distribution, and further protects outer layers and the receiving surfaces so they remain permeable.
Stage 6	A mat of coarse random fibers separates more suspended solids from the effluent.
Stage 7	Effluent passes into the geo-textile fabric and grows a protective bacterial surface.
Stage 8	Sand wicks liquid from the geo-textile fabric and enables air to transfer to the bacterial surface.
Stage 9	The fabric and fibers provide a large bacterial surface to break down solids.
Stage 10	An ample air supply and fluctuating liquid levels increase bacterial efficiency.

SYSTEM DIAGRAM

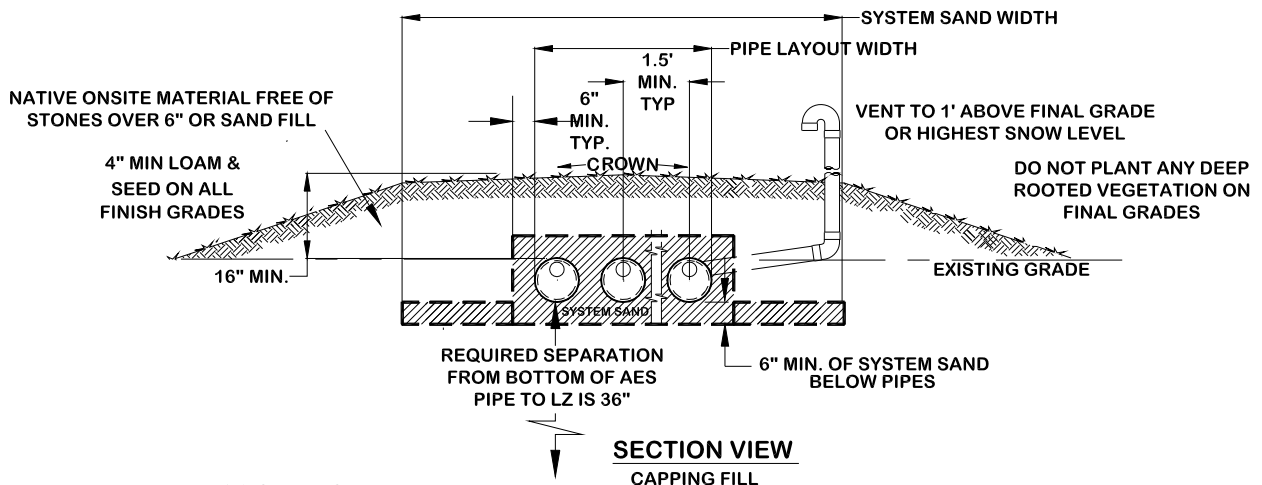
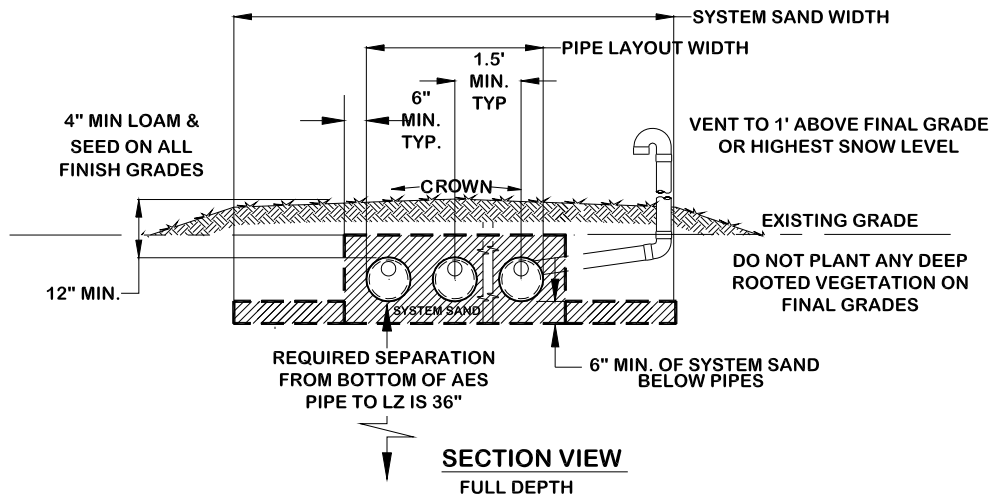
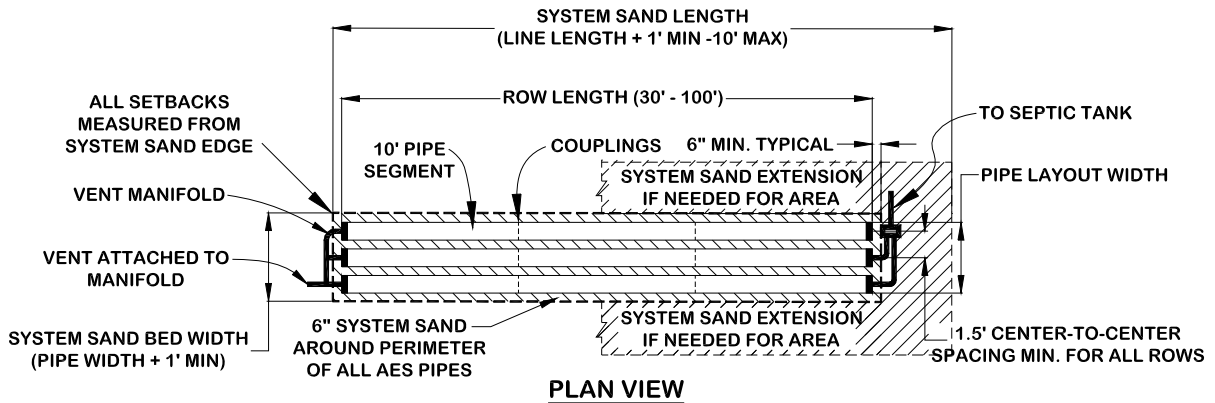

NOTES:

- ALL ROWS 1.5' SPACING MINIMUM.
- ROWS CENTERED IN SYSTEM SAND.
- VENTING REQUIRED FOR ALL CONFIGURATIONS.

Section B

Advanced Enviro-Septic® System Components

Advanced Enviro-Septic® pipe



- Plastic pipe made with a significant percentage of recycled material
 - Each unit is approximately 10 ft. long (can be cut easily to any length)
 - Ridged and perforated with skimmer tabs on interior
 - Bio-Accelerator™ layer aligned along bottom of pipe exterior
 - Covered with a mat of randomly-oriented plastic fibers
 - Surrounded by a non-woven geo-textile fabric stitched in place
 - Exterior diameter of 12 in.
 - Each unit (10 ft.) has a liquid holding capacity of approx. 48 gallons
 - Flexible enough to bend up to 90°
-

Offset adapter



An offset adapter is a plastic fitting with a 12 in. diameter and a hole designed to accept a 4 in. inlet pipe, raised connection, or vent pipe. The hole is to be in the twelve o'clock position.

Note: The hole in the offset adapter will accommodate Schedule 20 to 40 PVC.

Double offset adapter



A double offset adapter is a plastic fitting with a 12 in. diameter and two holes designed to accept a 4 in. inlet pipe, raised connection, vent or vent manifold, and/or bottom drain piping, depending upon the particular requirements of the design configuration.

The two 4 in. holes are to be aligned in the 12 o'clock and 6 o'clock positions. The holes are positioned 1 in. from the outside edge of the double offset adaptor and 2 in. from each other.

Note: The holes in the double offset adapter will accommodate Schedule 20 to 40 PVC.

Coupling



A coupling is a plastic fitting used to create a connection between two pieces of Advanced Enviro-Septic® pipe. The coupling features a snap-together locking device and ridges that are designed to fit over the ridges of the Advanced Enviro-Septic® pipe, creating a quick and easy way to join pipe sections together easily and securely.

Advanced Enviro-Septic® System Components, continued

Distribution Box A Distribution Box, also called a “D-box,” is a device used to distribute effluent coming from the septic tank in a system. D-boxes are also sometimes used for velocity reduction (see p. 22). D-boxes come in various sizes and with a varying number of outlets. Concrete D-boxes are preferred, some are made of plastic.

Flow equalizers (see below) are installed in the D-box openings to equalize distribution; they help ensure equal distribution in the event that the D-box settles or otherwise becomes out of level. Unused openings in D-boxes are to be covered, plugged or mortared.

Flow Equalizers A flow equalizer is an adjustable plastic insert installed in the outlet holes of a distribution box to equalize effluent distribution to each outlet whenever flow is divided.

Septic Tank

- The Advanced Enviro-Septic® System is designed to treat effluent that has received “primary treatment” in a standard septic tank.
- Effluent filters are not recommended by Presby Environmental, Inc. due to their tendency to clog, which cuts off the oxygen supply that is essential to the functioning of the Advanced Enviro-Septic® System.
- If you are required to use an effluent filter in a gravity fed system due to state or local requirements, the effluent filter selected must allow the free passage of air to ensure the proper functioning of the system.

System Sand The System Sand that surrounds the Advanced Enviro-Septic® pipes is an **essential** component of the system. It is **critical** that the correct type and amount of System Sand is used when constructing the system. System Sand must be coarse to very coarse, clean, granular sand, free of organic matter. It must adhere to **all** of the following percentage and quality restrictions:

- No stones over ¾ in. in diameter
- Percentage Restrictions (by total weight):
 - 35% maximum retained by a #10 sieve
 - 40-90% retained by a #35 sieve
 - Fines Quality Restrictions: A maximum of 2% of total sand may pass through a #200 sieve
- ASTM C-33 or other DOT sands may be acceptable for use as System Sand providing that no more than 2% can pass a #200 sieve.

System Sand is placed a minimum of 6 in. in all directions from the Advanced Enviro-Septic® pipes (6” below pipes, 6” between rows, above pipes and around outer perimeter).

Advanced Enviro-Septic® System Components, continued

Component Handling & Storage

- Keep mud, grease, oil, etc. away from all components.
 - Avoid dragging pipe through wet or muddy areas.
 - Store pipe on high and dry areas to prevent surface water and soil from entering the pipes or contaminating the fabric prior to installation.
 - The outer fabric of the Advanced Enviro-Septic® pipe is ultra-violet stabilized; however, this protection breaks down after a period of time in direct sunlight. To prevent damage to the fabric, cover the pipe with an opaque tarp.
-

Section C
System Sizing, AES Pipe Requirements & Design Example

Table A

PERC RATE	System Sand Bed Area	Two Bedroom	Three Bedroom	Four Bedroom	AES AMOUNTS
min/inch	gpd/sq.ft.	Sq. Ft.	Sq. Ft.	Sq. Ft.	MIN. Units Per Bedroom (Unit = 10')
5	0.71	338.09	507.14	676.19	5
10	0.71	338.09	507.14	676.19	5
15	0.71	338.09	507.14	676.19	5
20	0.71	338.09	507.14	676.19	6
25	0.63	378.00	567.00	756.00	6
30	0.58	414.08	621.12	828.16	6
35	0.54	447.26	670.88	894.51	7
40	0.50	478.14	717.20	956.27	7
45	0.47	507.14	760.71	1014.28	7
50	0.45	534.57	801.86	1069.15	7
55	0.43	560.66	841.00	1121.33	7
60	0.41	585.60	878.39	1171.19	7
65	0.39	609.51	914.26	1219.01	7
70	0.38	632.51	948.77	1265.03	7
75	0.37	654.72	982.07	1309.43	7
80	0.35	676.19	1014.28	1352.37	7
85	0.34	697.00	1045.50	1394.00	7
90	0.33	717.20	1075.81	1434.41	7
95	0.33	736.86	1105.29	1473.72	7
100	0.32	756.00	1134.00	1512.00	7
105	0.31	774.67	1162.00	1549.34	7
110	0.30	792.90	1189.35	1585.80	7
115	0.30	810.72	1216.08	1621.44	7
120	0.29	828.16	1242.23	1656.31	7

Based on 120gpd. per Bedroom.
Two bedroom minimum.

System Sizing, AES Pipe Requirements & Design Example, continued

Calculating the Amount of AES pipe required

- Residential systems require 50, 60 or 70 ft. of AES per bedroom.
 - Commercial system pipe requirements are calculated at 1 ft. of AES pipe per 2 gallons per day of design flow: $\text{Commercial Daily Design Flow} \div 2 = \text{minimum AES pipe required (in ft.)}$.
-

Requirements Assume Normal Domestic Strength Effluent

System Sand Bed Sizing and minimum AES pipe requirements presented here were developed assuming normal, domestic strength effluent which has received primary treatment in a septic tank.

When designing a system that will treat unusual or high strength wastes, using additional AES pipe is recommended. Please consult our Technical Staff at (800) 473-5298 for guidance.

Design Example

Design a four-bedroom residential AES System in soils with a perc rate of 30:

- System Sand bed area from Table A, p. 8 = 828 sq. ft. (minimum)
- Minimum AES pipe from Table A, p.8 4 bedrooms x 60 ft. = 240 ft.

AES Pipe Layout Examples (a few of the many possible configurations):

- 4 rows of pipe 60 ft. long or 6 rows of pipe 40 ft. long (uses minimum amount of pipe, 240 ft.)
- 8 rows of pipe 30 ft. long or 3 rows of pipe 80 ft. long (row lengths rounded up to 10 ft. increments for ease of installation, uses 240 ft. of pipe)

System Sand Bed Dimension Example:

- Assume 4 rows of pipe, 60 ft. long, System Sand bed area of 828 sq.ft.
- Bed length: 60 ft. row length + 10 ft.* System Sand = 70 ft. (* 6 in. min. – 5' max System Sand required beyond the end of each row)
- Bed width: 828 sq. ft. \div 70 ft. length = 11.82 ft. width

Confirm Bed Width above will accommodate number of rows:

- Minimum System Sand bed width for 4 rows using 1.5 ft. center-to-center spacing is 6.5 ft.
- Calculations above resulted in 11.82 ft. width, which is sufficient for 4 rows of pipe centered in sand bed.

Confirm System Sand Bed Area is sufficient:

- 70 ft. length x 11.82 ft. width = 828 sq. ft.
-

Section D System Configurations

Introduction

This section presents the various single-level design configurations of the Advanced Enviro-Septic® System. The system configuration to be used is determined by:

- Characteristics of the naturally-occurring soils: Percolation Rate (“perc rate,” expressed in Minutes per Inch “mpi”).
- The daily design flow
- Other characteristics specific to the particular site

System Configurations

The following Advanced Enviro-Septic® System configurations are presented in this Section:

- D-box configuration (p. 10)
- Multiple Bed configurations (pp. 11-12)
- Unique Site Solutions for any soil type (p. 13)

D-Box Distribution Configuration

- All rows in a D-box configuration must be the same length and utilize flow equalizers to ensure effluent is distributed equally to each row in the system.
- Use a vent manifold to ensure adequate air flow through each row (refer to illustration for D-Box Distribution Configuration below).

D-Box Distribution Configuration (Level Bed)

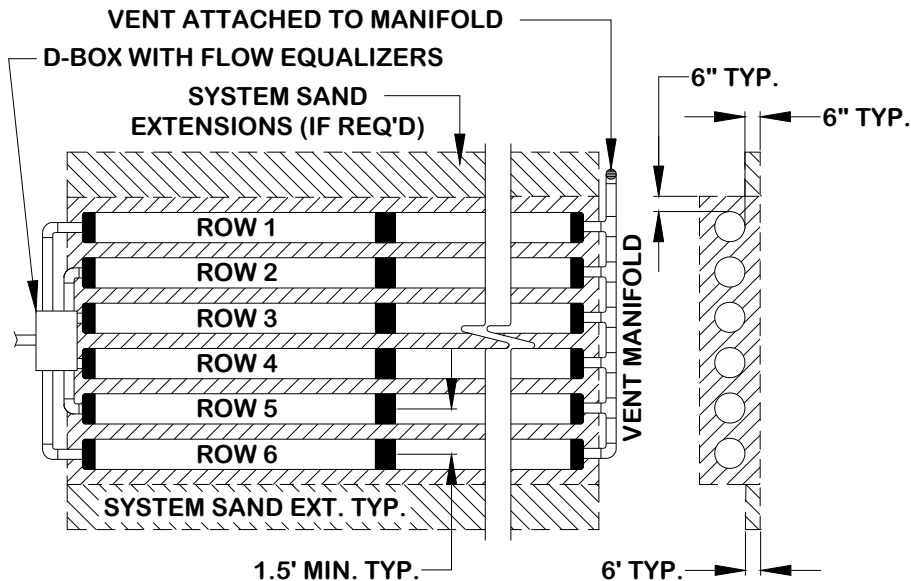

Multiple Bed Distribution

Introduction

Multiple Bed distribution may be used to accommodate site constraints or to handle large daily design flows. It incorporates:

- Two or more beds
- Each bed receives an equal amount of effluent from a D-box with equalizers.

When to use Multiple Bed Distribution

- Daily design flow is greater than 800 gpd
- Required in perc rates 61-120 mpi

Flow Equalizers Required

All D-boxes used to divide effluent flow require flow equalizers in their outlets. Each flow equalizer is limited to a maximum of 20 gpm.

Bed Requirements

- Each bed must have the same minimum total feet of pipe.
- Each bed must have at least two rows.
- The minimum linear feet of pipe per bed is determined by dividing the total linear feet required in the Advanced Enviro-Septic® System by the number of beds.
- Beds may be of different dimensions, provided that rows are not more than 100 ft. long. Longer, more narrow beds work best.
- Recommended minimum row length is 30 ft.
- Rows within a bed may vary in length to accommodate site constraints.

Multiple Bed Orientation

Multiple beds may be oriented along the contour of the site or along the slope of the site. End-to-end configurations are preferred; however, side-to-side configurations may be allowed with sufficient separation distance (see Bed Separation Distances, below).

Bed Separation Distances

Minimum bed separation distances:

- 5 ft. separation for end-to-end system beds (measured pipe to pipe) if elevation difference is 1 ft. or less.
- 10 ft. separation for end-to-end system beds (measured pipe to pipe) if elevation difference is greater than 1 ft. but less than or equal to 3 ft.
- 20 ft. separation for end-to-end beds if elevation difference is greater than 3 ft.
- 20 ft. separation for side-to-side beds regardless of elevation difference.

Minimum Bed Separation	
Elevation Differential	Required Bed Separation
12 in. or less	5 ft.
12 in. – 36 in.	10 ft.
> 36 in.	20 ft.
Side-to-Side	20 ft.

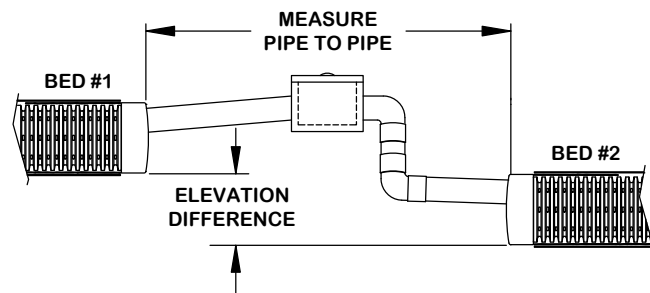

Multiple Bed Distribution, continued

Multiple Bed Distribution – equal linear footage of Advanced Enviro-Septic® pipe in each bed

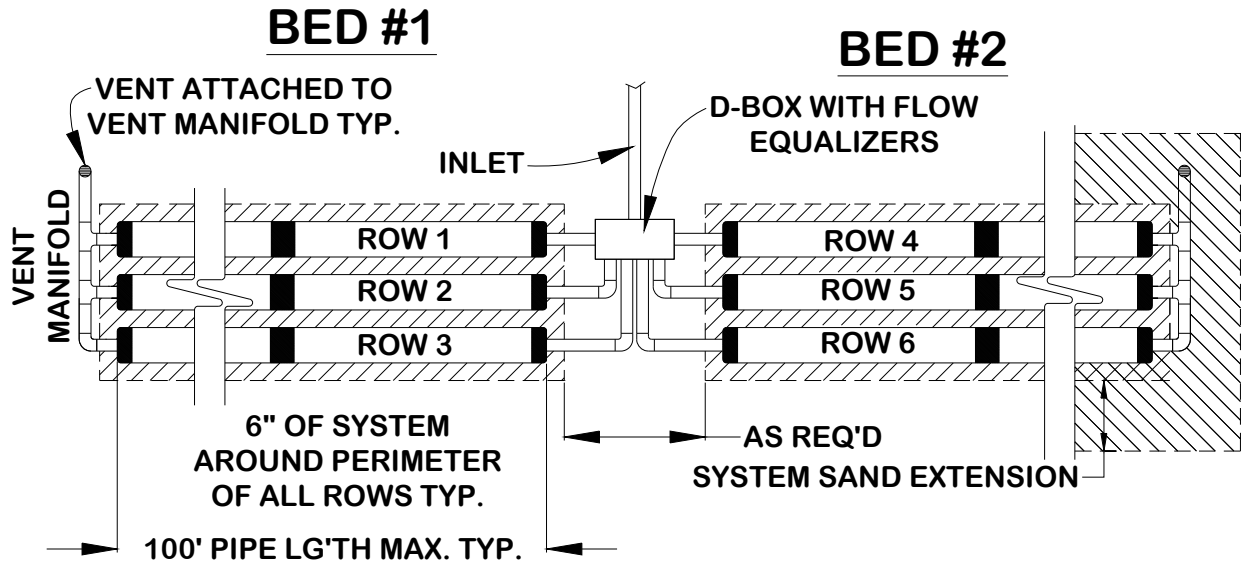

Note: This Multiple Bed configuration may be used in all soil types. See previous page for minimum bed separation distances.

Bed separation for Side-to-Side layout

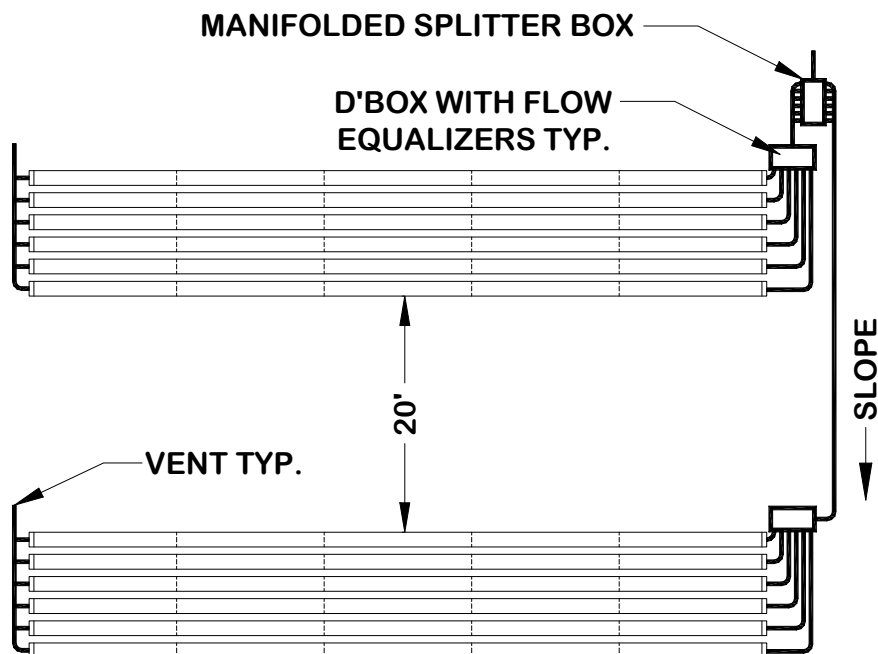

Unique Site Solutions for any soil type

Introduction

The configurations described in this Section may be used to accommodate site constraints. These configurations may be used in any soil type (perc rates 1-120 mpi).

Angles

Angled configurations generally have one or more specific bends, but the rows should follow the contour of the site. Rows are angled by bending pipes or through the use of offset adapters. The following layouts may be used in any soil type.

Note: A 10 ft. length of Advanced Enviro-Septic® pipe may be bent up to 90°.

SYSTEM CURVED ABOUT RADIUS

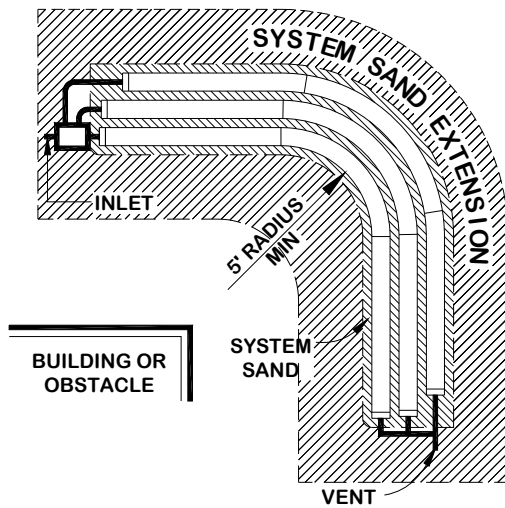

SYSTEM LAYOUT AT 90°

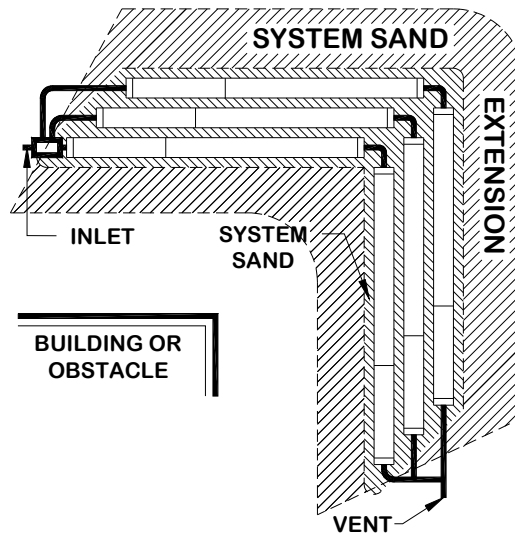

Curves

Curved configurations work well around structures, setbacks, and slopes. Multiple curves can be used if dictated by the contour of the site.

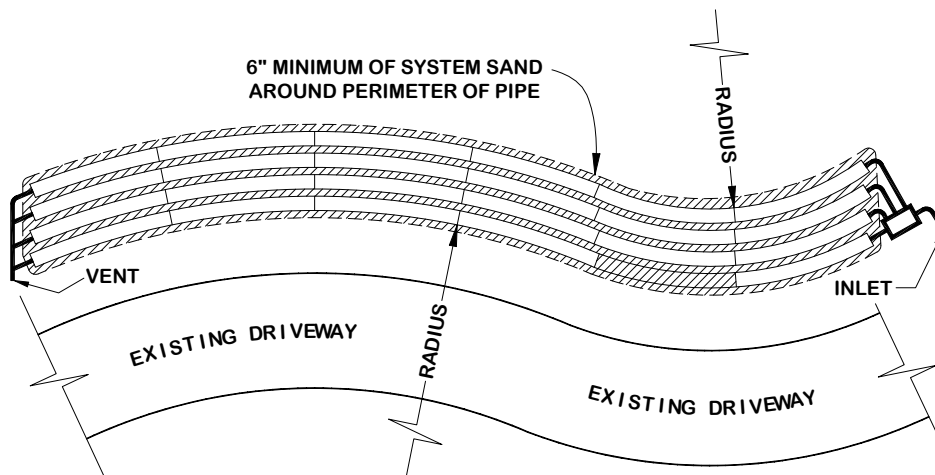

Side Slope Tapering and Sloping Systems

Configuration not requiring side slope tapering

If all parts of the system, including cover material, are at or below original grade, the system will not require side slope tapering.

Configuration requiring side slope tapering

- If any part of the system (including soil cover) is above original grade, the system will require side slope tapering.
 - Side slope tapering is used to blend the system into the terrain, making it both less susceptible to erosion and less noticeable.
 - Also refer to Section L, Final Grading, pp. 34-35
-

Section E
Design Criteria for Delaware

Center-to-Center Spacing of Rows

- Center-to-center spacing of Advanced Enviro-Septic® rows is a minimum of 1.5 ft. for Advanced Enviro-Septic® Systems.
 - Center-to-center spacing is measured from the center of one pipe to the center of the pipe in the next row.
 - Center-to-center spacing of 1.5 ft. results in the minimum of 6 in. of System Sand between each row of Advanced Enviro-Septic® pipe.
-

Daily Design Flow Calculations Commercial

Commercial systems will use 1 ft. of AES pipe for every 2 gpd of daily design flow:
Daily design flow (gal/day) ÷ 2 = Minimum AES pipe (ft.)

Daily Design Flow Calculations Residential

Residential daily design flows are calculated based on 120 gallons per day (“gpd”) per bedroom.

D-Box Manifold

- A D-box manifold is utilized to equalize flow.
- Flow equalizers should be used on all D-box outlets.
- Unused D-box outlets must be covered, plugged or mortared.
- This configuration is especially useful when designing for large daily design flows. See “Velocity Reduction,” this Section, p. 21.

Distribution box manifold is used to divide flow evenly to separate beds or sections:

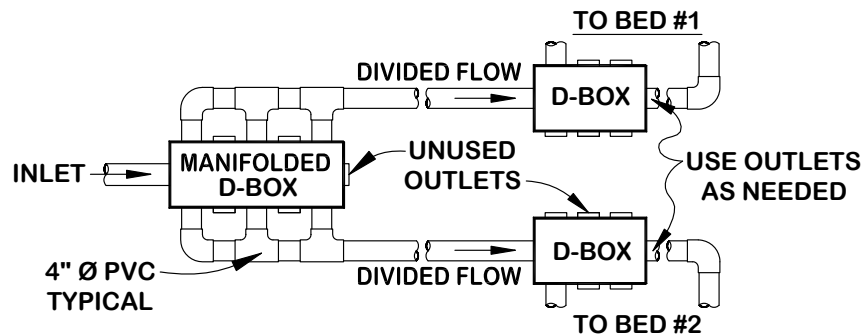

Note: Utilizing every other outlet will provide room for required piping and allow for easier installation. Install flow equalizers on all used outlets.

Design Criteria for Delaware, continued

End-to-End Preferred Over Side-to-side

If site conditions permit, end-to-end system bed configurations are preferable to side-to-side system bed configurations. See illustrations on p. 12.

Filters

- All septic tanks must be equipped with baffles or tees to reduce the amount of solids exiting the tank and entering the Advanced Enviro-Septic® System.
 - Effluent filters are not recommended by Presby Environmental, Inc. due to their tendency to clog, which cuts off the oxygen supply that is essential to the functioning of the Advanced Enviro-Septic® System.
 - If you are required to use an effluent filter in a gravity fed system due to state or local requirements, the effluent filter selected must allow the free passage of air to ensure the proper functioning of the system.
-

Garbage Disposals

- If a garbage disposal is utilized, we recommend that the required liquid capacity of the septic tank be increased by 50%.
 - Multiple compartment septic tanks or multiple tanks are preferred.
 - If a garbage disposal is used, the septic tank will likely require more frequent pumping (see Operation & Maintenance, Section M, p. 36).
-

Horizontal Separation Distances

Minimum horizontal separation distances (also called “set-backs”) must comply with state and/or local requirements. Horizontal separation distances are measured from the outermost edge of the System Sand bed.

Interceptor Drains

Interceptor Drains, if used, must be upslope of the AES System and a minimum of 10 ft. away from all AES pipes. AES pipe is excellent for use in constructing interceptor drains.

Maximum Row Lengths

To maintain efficient cycling within the AES pipe, the maximum row length is 100 ft. The longest, narrowest system design practical for the site is recommended to facilitate infiltration.

Minimum Number of Rows

All beds must have at least 2 parallel rows.

Design Criteria for Delaware, continued

Orientation of Pipes on System Sand Bed

For Advanced Enviro-Septic® Systems the System Sand extends horizontally a minimum of 6 in. beyond the outer perimeter of the Advanced Enviro-Septic® pipes, with the pipes centered on the System Sand bed.

See illustrations on p. 10

Pipe Length (Minimum) Required

- Residential systems: Total minimum length of Advanced Enviro-Septic® pipe is 50 ft. per bedroom.
- Commercial systems: A minimum of 1 ft. of pipe is required per every 2 gallons of design daily flow. Contact Presby Environmental for high strength effluent recommendations.

Design Criteria for Delaware, continued

Replacement Area Not Required

In the unlikely event that an Advanced Enviro-Septic® System needs to be replaced...

- It can be reinstalled in the same location, eliminating the need for a replacement system reserve area.
- All unsuitable material must be removed prior to replacement system construction.
- Dispose of hazardous materials properly.
- A reserve area may still be required per state or local regulations; contact the appropriate approving authority to determine if reserve area is required.

Note: Attempt Rejuvenation procedures **before** replacing the system. This simple process can often restore normal system function in a matter of days. Refer to Section N, Rejuvenation and Expansion, p. 37 and call PEI for technical assistance.

Required Depth Vertical Separation

- The minimum separation distance between the Advanced Enviro-Septic® Pipe and the highest limiting condition (LZ) in the soil profile is 36 in.
 - "Limiting Conditions" (LZ) include seasonal high water table (SHWT) and ledge, bedrock or impermeable soils (perc rates greater than 120 mpi).
 - Full Depth installations must have 60" of soil or greater to LZ.
 - Capping Fill installations must have 48"-59" of soil or greater to LZ.
-

Row Orientation

Advanced Enviro-Septic® rows must be laid level to within 1 in. end-to-end and preferably will be approximately parallel to the contour of the site.

Septic Tank and D-box Elevations

The outlet of a septic tank or D-box must be set at least 2 in. above the highest inlet to the first Advanced Enviro-Septic® row, with the connecting pipe slope not less than 1% (approximately 1/8 in. per foot.)

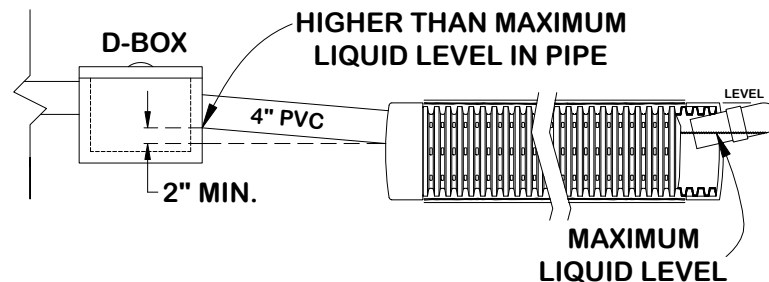

Design Criteria for Delaware, continued

**System Sand
Bed Area
(Minimum)**

Refer to Table A on p. 8.

**System Sand
Bed Vertical
Dimensions**

The overall height of an Advanced Enviro-Septic® System measures 24 in. (including System Sand, not including fill or cover materials):

- Min. 6 in. of System Sand below the Advanced Enviro-Septic® pipe;
 - 12 in. diameter of the Advanced Enviro-Septic® pipe; and
 - 6 in. of System Sand above the Advanced Enviro-Septic® pipe.
 - The System Sand Extension is any portion of the System Sand bed that is more than 6 in. from the outermost perimeter of any Advanced Enviro-Septic® pipe; this portion of the System Sand bed needs to be a minimum of 6 in. deep. (See illustration on p. 10.)
-

**System Sand
Specifications**

It is **critical** to the proper functioning of the Advanced Enviro-Septic® System that the proper amount and type of System Sand be installed. Refer to Section I, System Sand and Fill Material Specifications, p. 28.

**Ten Foot
Increments
Work Best**

It is easier if row lengths are designed in exact 10 ft. increments since Advanced Enviro-Septic® pipe comes in 10 ft. sections. However, if necessary, the pipe is easily cut to **any** length to meet site constraints. Using 5 ft. increments minimizes waste of pipe material.

Design Criteria for Delaware, continued

Topographic Position Requirement

The topographic position of the site must be convex, hill slope, or flat. No onsite system may be located on concave slopes that concentrate surface or ground water flows unless up-slope terrain is sufficiently altered or interceptor drains are used to redirect water away from the system. Refer to Section H, Site Selection, p. 27 for additional information and tips about selecting the right location for an Advanced Enviro-Septic® System.

Velocity Reduction

- Velocity reducers are needed when there is excessive slope between the septic tank and the Advanced Enviro-Septic® System.
 - A velocity reducer at the system inlet is required if the velocity of the fluid entering the Advanced Enviro-Septic® pipes would create enough turbulence to disrupt the natural settling of suspended solids within the Advanced Enviro-Septic® pipes.
 - D-boxes with baffles or a velocity reducing tee are commonly used for velocity reduction.
-

Venting Requirements

All Advanced Enviro-Septic® Systems require venting. Refer to Section G, Venting Requirements, pp. 23-26.

Wastewater Strength

- All design criteria in this Manual assume “usual” or “typical” domestic wastewater strength. Designers should take any unusual wastewater characteristics into consideration when designing a system.
 - Where wastewater strength is high or wastes are unusual, additional Advanced Enviro-Septic® pipe is recommended. Please contact PEI for technical assistance.
-

Water Purification Systems

- Water purification systems and water softeners should **not** discharge into an Advanced Enviro-Septic® System.
- This backwash and the additional flow may overload the system. Designs should include an alternative means of dispersal.
- If there is no alternative means of disposing of this backwash, then the system will need to be “oversized.” Calculate the total amount of backwash in gpd, multiply by 2, and add this amount to the daily design flow and increase septic tank, AES pipe and System Sand bed size accordingly.
- Water purification systems and water softeners require regular routine maintenance; consult and follow the manufacturer’s recommendations.

Section F Venting Requirements

General Rule

- Adequate ventilation is **essential** to the proper functioning of the Advanced Enviro-Septic® System.
- Vent openings must be located to ensure the unobstructed flow of air through the entire Advanced Enviro-Septic® System.
- The low vent inlet must be a minimum of 1 ft. above final grade or elevation of highest anticipated snow accumulation.

When to Vent

- High and low vents are **required** for **all** systems.
- The roof (house) vent is the “high vent” in gravity systems.
- One 4 in. low vent is required for every 1,000 ft. of Advanced Enviro-Septic® pipe.
- A single 6 in. low vent may be installed instead of two 4 in. vents.
- The diameter of the vent manifold must match the vent stack diameter.

Vent Locations

Vent locations depend upon the type of system. For ease of illustration, most illustrations show high and low vents on opposite ends of the field; however, high and low vents may be installed on the same end of the field as long as the 10 ft. differential between high and low vents are maintained. Refer to illustrations on next page.

Gravity Systems

- A low vent through an offset adapter is installed at the end of each row, section or bed. A vent manifold may be used to connect the ends of multiple sections or rows.
- **The house (roof) vent functions as the high vent** as long as there are no restrictions or other vents between the low vent and the house (roof) vent.

Proper gravity system vent configuration

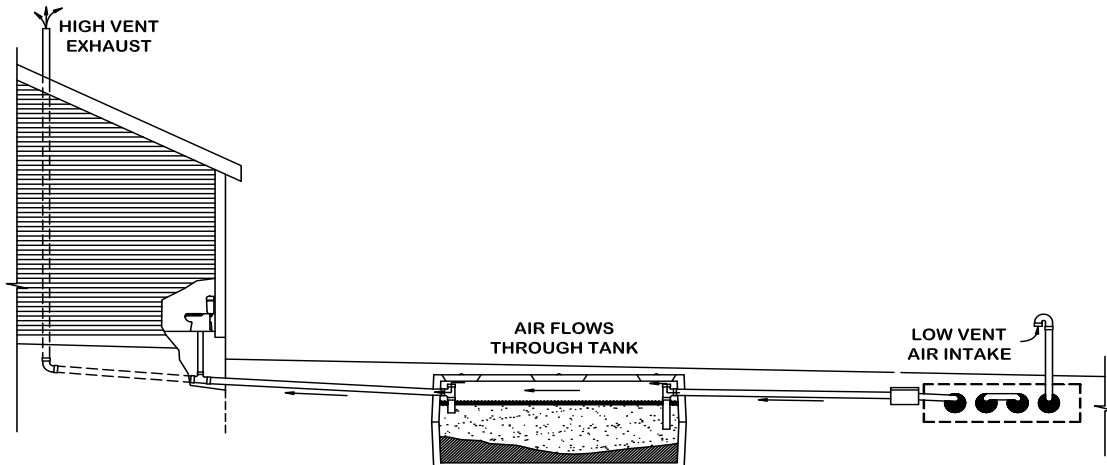

Air flow is established by the High Vent's chimney effect, which draws air into the Low Vent, through the Advanced Enviro-Septic® pipes, through the septic tank and exhausting through the roof vent.

Venting Requirements, continued

Vent Manifolds A vent manifold may be incorporated to connect the ends of a number of Sections or rows of Advanced Enviro-Septic® pipe to a single vent opening. See illustration of D-box Distribution Configuration on p. 10.

Vent Piping Slope Vent piping should slope downward toward the system to prevent moisture from collecting in the pipe and blocking the passage of air.

Remote Venting If site conditions do not allow the vent pipe to slope toward the system, or the owner chooses to utilize remote venting for aesthetic reasons (causing the vent pipe not to slope toward the system), the low point in the vent line must be drilled creating several ¼ in. holes to allow drainage. This procedure may **only** be used if the vent pipe connecting to the system has:

- A **high point** that is above the highest point of the Advanced Enviro-Septic® row or D-box that it is connected to; and,
- A **low point** opened for drainage which is above the SHWT. (See illustration below.)

REMOTE DIFFERENTIAL VENTING

(NOT TO SCALE)

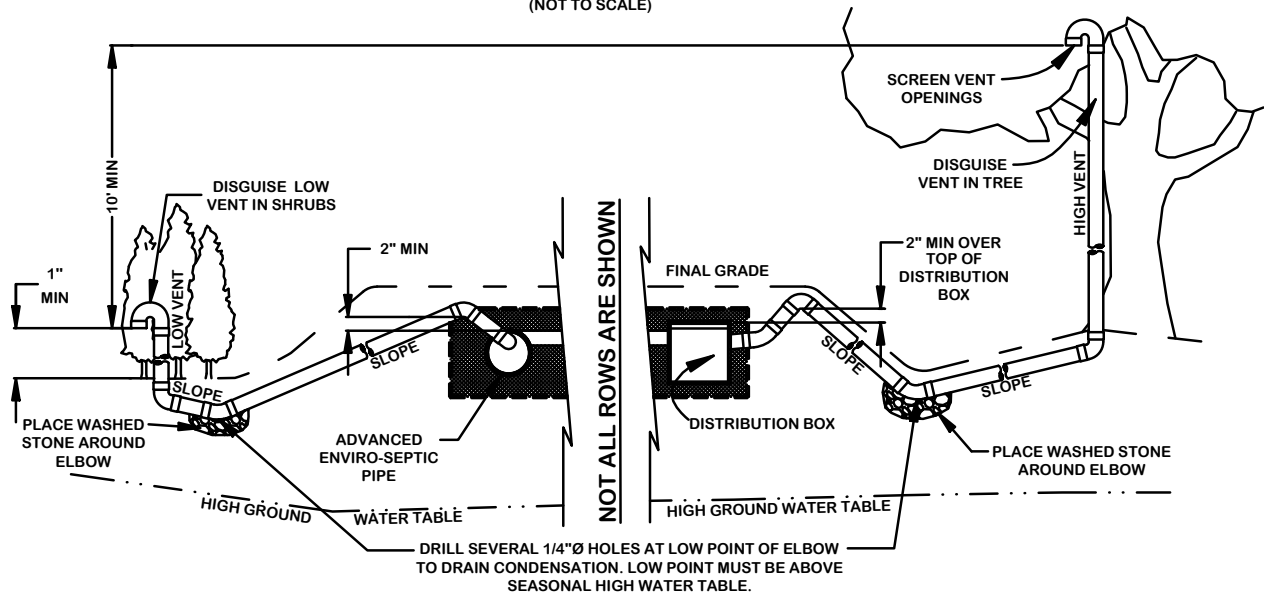

SectionG
Site Selection

Determining Site Suitability	In order to decide if a particular site is suitable for an Advanced Enviro-Septic® system, measure the distance down from existing grade to the highest layer of SHWT, ledge, bedrock or impermeable soil in the soil horizon in the proposed system site and a 50 ft. perimeter. There must be a minimum of 48 in. of unsaturated <i>in situ</i> soil in order to install an Advanced Enviro-Septic® System, or the distance required by Delaware regulations.
Topography	Locate systems on convex, hill slope or level locations that do not concentrate surface flows. Avoid swales, low areas, or toe-of-slope areas that may not provide sufficient drainage away from the system.
Surface Water Diversions	Surface water runoff must be diverted away from the system. Diversions must be provided up-slope of the system and designed to avoid ponding. Systems must not be located in areas where surface or groundwater flows are concentrated.
Dispersal Area	Systems must be located where adjacent soils in the proposed system location and a 50 ft. perimeter are suitable for dispersing water away from the system.
Containment	Systems should not be located where structures such as curbs, walls or foundations might adversely restrict the soil's ability to transport water away from the system.
Hydraulic Loading	Systems should not be located where lawn irrigation, roof drains, or natural flows increase water loading to the soils around the system.
Access	Systems should be located to allow access for septic tank maintenance and to at least one end of all Advanced Enviro-Septic® rows in case Rejuvenation is needed.
Rocky or Wooded Areas	Use caution when preparing a rocky or wooded site, since removal of trees, stumps, roots, rocks, etc. may alter the soil's ability to accept water. No trees or shrubs should be located within 10 ft. of the system to prevent root infiltration.
Reserve Area	Since Advanced Enviro-Septic® preserves the characteristics of the underlying soils, it is not necessary to designate a reserve area for a replacement system. A reserve area may still be required per state or local regulations; contact the appropriate approving authority to determine if reserve area is required.

Section H
System Sand & Fill Material Specifications

System Sand

The System Sand that surrounds the Advanced Enviro-Septic® pipes is an **essential** component of the system. It is **critical** that the correct type and amount of System Sand is used when constructing the system. System Sand must be coarse to very coarse, clean, granular sand, free of organic matter. It must adhere to **all** of the following percentage and quality restrictions:

- No stones over ¾ in. in diameter
- Percentage Restrictions (by total weight):
 - 35% maximum retained by a #10 sieve
 - 40-90% retained by a #35 sieve
 - Fines Quality Restrictions: A maximum of 2% of total sand may pass through a #200 sieve
- ASTM C-33 or other DOT sands may be acceptable for use as System Sand providing that no more than 2% can pass a #200 sieve.

System Sand is placed a minimum of 6 in. below all Advanced Enviro-Septic® pipes, a minimum of 6 in. above the Advanced Enviro-Septic® pipes, a minimum of 6 in. between Advanced Enviro-Septic® rows, and a minimum of 6 in. horizontally around the perimeter of the Advanced Enviro-Septic® pipes.

**Sand Fill or
Fill Material**

Sand fill is to be used to raise the elevation of the system in order to meet the required separation distance from the SHWT or other restrictive feature. It is also used in constructing side slope tapering. This sand shall be clean, bank run sand, free of topsoil, organic matter or debris and containing no stones larger than 6 in.. No more than 15% of this sand shall pass through a #100 sieve and no more than 5% shall pass through a #200 sieve.

Naturally-occurring soils removed when excavating the site may be used for constructing side slope tapering, provided the soil contains no organics, stones larger than 6 in., stumps or other debris.

Note: System Sand may be used in place of sand fill.

**Topsoil
(a.k.a. "Loam")**

Suitable earth cover, similar to the naturally occurring soil at the site and capable of sustaining plant growth, is required as the uppermost layer over the entire system (and side slope tapering). The topsoil layer should be a minimum of 4 in. deep and should be immediately seeded or mulched in order to prevent erosion.

Section I Preparing for Installation

Avoid compaction

Avoid compaction of the soils in the area receiving System Sand, the side slope tapering and the area down-slope of the proposed system. Materials and equipment must not be stored or transported over the receiving soils.

Excavation Procedures

- Locate machinery up-grade or alongside of the proposed system area when excavating, avoiding the system area.
 - Excavate the receiving area with a toothed bucket only. Do not excavate the receiving area with a finish bucket because this will compact or smear the soil.
 - A minimum of 12 in. of System Sand or sand fill must be installed prior to equipment traveling above the system to avoid compaction and destruction of soil structure.
-

Avoid Drying Soil

Dispersal area soils must not be allowed to dry. Sun or extended dry air conditions may alter soil structure. System Sand must be installed immediately following excavation of the receiving area.

Avoid Precipitation and Erosion

- Do not excavate the system receiving area immediately after, during or prior to precipitation.
 - Install sediment/erosion control barriers prior to beginning excavation to protect the system from possible surface water flows during construction.
 - Warm, dry weather conditions are ideal for system installation. Check the weather forecast and schedule installation accordingly.
-

Avoid Frozen Soil

If possible, do not excavate the soils in the system area during frozen conditions. If you have no alternative but to install the system in cold weather, be prepared to work quickly, do not allow excavated soil to cool, and install System Sand immediately. Cover the System Sand with a protective layer of insulation or hay/straw and canvas if overnight temperatures may be below freezing during the installation process.

Avoid Wet Soil Conditions

Do not excavate in and around the system area when the soil is wet. If soil forms a rod 1/8 in. or less in diameter when rolled with the fingers, or if it does not crumble easily, it contains too much moisture to be worked.

Install Sand

System Sand or sand fill must be installed immediately following excavation of the system area. If it is not, repeat the "Excavation Procedures" above.

Construction Equipment

Construction equipment may travel across the system area only after the installation of a minimum of 12 in. of sand fill or System Sand. If at all possible, keep equipment off the System Sand.

Preparing for Installation

Component Handling

- Keep mud, grease, oil, etc. away from all components.
 - Avoid dragging pipe through wet or muddy areas.
 - Store pipe on high and dry areas to prevent surface water and soil from entering the pipes or contaminating the fabric prior to installation.
 - The outer fabric of the Advanced Enviro-Septic® pipe is ultra-violet stabilized; however, this protection breaks down after a period of time in direct sunlight. To prevent damage to the fabric, cover the pipe with an opaque tarp or store indoors.
-

Stake-out System Location

- Locate and stake out the System Sand bed (including System Sand extension area if needed), and areas impacted by side slope tapering on the site according to the approved plan.
- Double-check that all set-back requirements are met. Remember, horizontal set-backs are measured from the outermost edge of the Advanced Enviro-Septic® pipe.
- Confirm that the site complies with the parameters in Section H, Site Selection, p. 27.

Section J
Installation & Construction Procedures

**Critical
Reminder
Prevent
Soil
Compaction**

It is critical to keep excavators, backhoes, and other equipment off the excavated or tilled surface under and around where the treatment system will be located. Before installing the System Sand, excavation equipment should be operated around the bed perimeter and not on the bed itself. During all stages of installation, avoid compacting soil adjacent to the bed as much as possible.

**Tree Stump
Removal**

- Remove all tree stumps and the central root system below grade by using a backhoe or excavator with a mechanical “thumb” or similar extrication equipment, lifting or leveraging stump in a manner that minimizes soil disturbance.
 - Do not locate equipment within the limits of the system area.
 - Avoid soil disturbance, relocation, or compaction.
 - Avoid mechanical leveling or tamping of dislodged soil.
 - Fill all voids created by stump or root removal with System Sand.
-

**Install
System Sand
and/or
Fill
Immediately
After
Excavation**

- To protect the tilled area (System Sand bed area) from damage by precipitation, System Sand should be installed immediately after tilling.
 - When installing the System Sand, work off either end or the uphill side of the system to avoid compacting soil (see “**Critical Reminder**” at the beginning of this section).
 - When installing sand, keep at least 12 in. of sand between the vehicle tracks and the tilled soil of the site.
 - Tracked construction equipment should not travel over the installed system area until at least 1 ft. of cover material is placed over the Advanced Enviro-Septic® pipes.
 - Construction equipment with wheels/tires should not travel over the installed system area until at least 18 in. of cover material is placed over the Advanced Enviro-Septic® pipes.
-

Installation Procedures, continued

Row Installation Sequence

1. Install a minimum of 6 in. of System Sand to the elevation where the bottom of Advanced Enviro-Septic® pipes will be, and install the sand on side slope tapering to allow machinery movement around the perimeter of the system. Rake the System Sand where the Advanced Enviro-Septic® pipes will be installed so it is as level as possible before placing pipes on the System Sand. This will make it easier to level the pipe rows.
 2. Locate Advanced Enviro-Septic® rows horizontally to tie points on site.
 3. Locate Advanced Enviro-Septic® rows vertically using a laser level or transit. Lift or lower the pipes at couplings using a hand shovel and adding or removing System Sand as necessary.
 4. Drop System Sand along each row of couplings being careful to avoid moving the rows.
 5. Add or remove System Sand along rows to level. The rows may be raised by straddling them and pushing additional System Sand below the pipes with your feet. A hand shovel may be scraped along the System Sand below the pipes to remove a small amount if needed.
 6. Re-check horizontal and vertical locations. Re-check that pipes are level to within 1 in. end-to-end.
 7. Add System Sand between and around the Advanced Enviro-Septic® pipes, leaving the uppermost surface of the pipe exposed to allow for system inspection (if required by local approving authority).
-

D-Box Installation

It is essential that the D-box remain level after installation in order to ensure even distribution to the all pipes within the system. Be sure D-boxes are placed level on undisturbed soil, compacted sand, pea gravel base, or concrete pad. Take care when backfilling that the D-box remains level.

Level Tolerances

Use a laser level or transit to install the pipes level within 1 in. end-to-end. Out-of-level pipe installation may affect system performance. Variations beyond a total of 1 in. are **not acceptable.**

Installation Procedures, continued

Row Spacers

Sand may be used to keep pipe in place while covering, but simple tools may also be constructed for this purpose. An example is shown below.

Caution: Remove all tools used as row spacers before final covering.

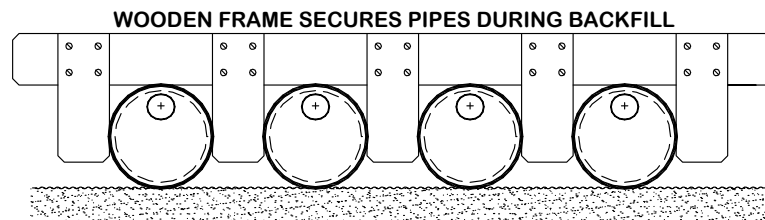

Install System Sand

- Spread System Sand between the rows.
 - Straddle each row of pipe and walk heel-to-toe its entire length, ensuring that System Sand fills all void spaces beneath the Advanced Enviro-Septic® pipe.
 - Finish spreading System Sand to the top of the pipes for inspection purposes (if required in your area).
 - Confirm that all rows of pipe are level to within 1 in. end-to-end.
 - After inspection (if required) proceed to backfilling and final grading.
-

Section K Final Grading

Side-Slope Tapering

To prevent erosion, all Advanced Enviro-Septic® Systems with any part of the system (including cover material) above original grade require side slope tapering on each side beyond the outer edge of the System Sand bed, tapering to a 2:1 slope.

See Section I, p. 28 for Fill Material specifications.

Install Remaining 6 in. of System Sand

After the installed system has been inspected (if required by local approving authority), install 6 in. of System Sand above the pipes. DO NOT install any barrier materials on top of the System Sand.

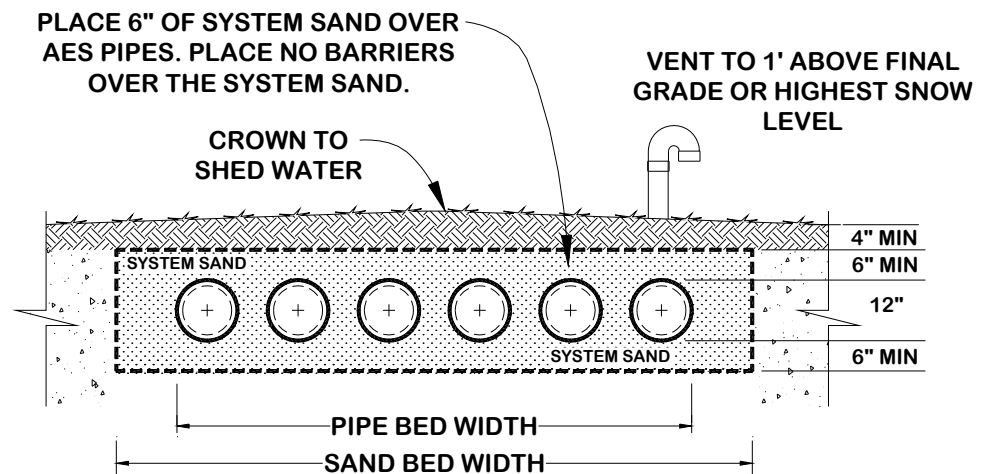

Final Grading

Final grading of the entire site should redirect surface water flows so that they do not collect in the system bed area. The system bed must slope or have a crown to ensure that surface water runoffs do not collect on the system. Systems should not be located where lawn irrigation, roof drains, or natural flows increase water loading to the soils around the system.

Erosion Control

Construct and maintain surface diversions, grading, silt fence, seeding and mulching to minimize concentration of surface water flows and erosion.

Cover Requirements

A minimum of 4 in. of topsoil (loam) capable of supporting plant growth is required over the System Sand or sand fill.
Full Depth
Capping Fill

Mulch or Seed

Immediately apply mulch or seed with grass, wildflowers or other shallow-rooted native vegetation to prevent erosion of the system bed.

Final Grading, continued

What Not to Plant

No trees or shrubs should be located on or within 10 ft. of the system perimeter (including side slope tapering) to prevent roots from growing into and damaging the system. If the system includes a perimeter drain, there should be no trees or shrubs planted closer than 10 ft. from the location of the perimeter drain. Do not plant gardens for human consumption in the vicinity of the wastewater treatment system.

Section L Operation & Maintenance

Proper Use

The Advanced Enviro-Septic® Wastewater Treatment System requires minimal maintenance provided the system is not subjected to abuse. An awareness of proper use and routine maintenance will guarantee system longevity. All system owners are encouraged to obtain a copy of our Owner's Manual, which is available from our website, www.PresbyEnvironmental.com.

System Abuse Conditions

The following conditions constitute system abuse:

- Liquid in high volume (excessive number of occupants, excessive use of water in a short period of time, leaking fixtures, whirlpool tubs, hot tubs, water softening equipment or additional water discharging fixtures if not specified in system design).
- Solids in high volume (excessive number of occupants, paper products, personal hygiene products, garbage disposals or water softening equipment if not specified in system design)
- Antibiotic medicines in high concentrations
- Cleaning products in high concentrations
- Fertilizers or other caustic chemicals in any amount
- Petroleum products in any amount
- Latex and oil paints
- System suffocation (compacted soils, barrier materials, etc.)

Special Note: Presby Environmental, Inc., and most regulatory agencies do not recommend the use of septic system additives.

System Maintenance/ Pumping of the Septic Tank

- Inspect the septic tank at least once every two years under normal usage.
 - Pump the tank when surface scum and bottom sludge occupy one-fourth or more of the liquid depth of the tank.
 - If a garbage disposal is used, the septic tank will likely require more frequent pumping.
 - After pumping, inspect the septic tank for integrity to ensure that no groundwater is entering it. Also check the integrity of the tank inlet and outlet baffles and repair if needed.
 - Inspect the system to ensure that vents are in place and free of obstructions.
 - Effluent filters are not recommended because of their tendency to clog and cut off oxygen to the system. If a filter is used, it will require diligent maintenance and cleaning to prevent it from becoming clogged. Follow filter manufacturer's maintenance instructions and inspect filters frequently.
-

Site Maintenance

It is important that the system site remain free of shrubs, trees, and other woody vegetation to within a minimum of 10 ft. of the system, including the entire System Sand bed area, and areas impacted by side slope tapering and perimeter drains (if used). Roots can infiltrate and cause damage or clogging of system components.

If a perimeter drain is used, it is important to make sure that the outfall pipes are screened to prevent animal activity. Also check outfall pipes regularly to ensure that they are not obstructed in any way.

Section M

Rejuvenation and Expansion of Advanced Enviro-Septic® Systems

Introduction	<p>This section provides an overview of bacteria rejuvenation and explains how to expand existing systems. These procedures may only be used with Advanced Enviro-Septic® Systems; it is difficult or impossible to rejuvenate other systems. The local approving authority must be contacted and permits obtained if required prior to Advanced Enviro-Septic® System rejuvenation, expansion, or replacement. Please contact PEI at 800-473-5298 for technical assistance <u>before</u> attempting rejuvenation procedures.</p>
What is Bacteria Rejuvenation?	<p>Bacteria rejuvenation is the return of bacteria to an aerobic state. Flooding, improper venting, alteration or improper depth of soil material cover, use of improper sand instead of System Sand, introduction of chemicals or medicines, and a variety of other conditions can contribute to converting bacteria in the Advanced Enviro-Septic® pipe from an aerobic to an anaerobic state. This conversion severely limits the bacteria's ability to effectively treat effluent, as well as making it more difficult for wastewater to pass through.</p>
How to Rejuvenate Bacteria	<p>System bacteria are "rejuvenated" when they return to an aerobic state. By using the following procedure, this can be accomplished in most systems without costly removal and replacement.</p> <ol style="list-style-type: none">1. Determine and correct the problem causing the bacteria conversion.2. Drain the system by excavating one end of each row and removing the offset adapters.3. If foreign matter has entered the system, flush the pipes.4. Safeguard the open excavation.5. Guarantee a passage of air through the system.6. Allow pipes to dry for a minimum of 72 hours. When the System Sand around the pipes returns to its natural color, this is an indication that the conversion to aerobic conditions has taken place.7. Re-assemble the system to its original design configuration. As long as there is no damage to the AES components, the original components may be reused.
System Expansion	<p>Advanced Enviro-Septic® Systems are easily expanded by adding equal lengths of pipe to each row of the original design, or by adding additional equal Sections, or by adding additional beds. Check with the appropriate approving authority to determine if a permit is required.</p>
Reusable Components	<p>Advanced Enviro-Septic® components are not biodegradable and may be reused. In cases of improper installation it may be possible to excavate, clean, and reinstall all system components.</p>
System Replacement	<p>If an Advanced Enviro-Septic® System requires replacement...</p> <ul style="list-style-type: none">• Remove the existing components and contaminated sand• If the soils under and around the system have not been compromised, replace in the same excavated location with new System Sand.• If components are not damaged, they may be cleaned and reused. <p>Note: Check with the appropriate approving authority to determine whether or not permits are required for system replacement.</p>